



GOKARAJU RANGARAJU
INSTITUTE OF ENGINEERING AND TECHNOLOGY

Department of Electrical & Electronics Engineering

Department of EEE

Course file

High Voltage Engineering

Course code: GR15A4147

(2018-19)

IV B.Tech - I SEMESTER

Name of the faculty: V.Usha Rani



**Gokaraju Rangaraju Institute of Engineering and
Technology**

Bachupally, Kukatpally, Hyderabad – 500 090. (040) 6686 4440



Course Title: High Voltage Engineering

Following documents are available in Course File.

| S.No. | Points | Yes | No |
|-------|--|-----|----|
| 1 | Institute and Department Vision and Mission Statements | ✓ | |
| 2 | PEO & PO Mapping | ✓ | |
| 3 | Academic Calendar | ✓ | |
| 4 | Subject Allocation Sheet | ✓ | |
| 5 | Class Time Table, Individual Timetable (Single Sheet) | ✓ | |
| 6 | Syllabus Copy | ✓ | |
| 7 | Course Handout | ✓ | |
| 8 | CO-PO Mapping | ✓ | |
| 9 | CO-Cognitive Level Mapping | ✓ | |
| 10 | Lecture Notes | ✓ | |
| 11 | Tutorial Sheets With Solution | ✓ | |
| 12 | Soft Copy of Notes/Ppt/Slides | ✓ | |
| 13 | Sessional Question Paper and Scheme of Evaluation | ✓ | |
| 14 | Best, Average and Weak Answer Scripts for Each Sessional Exam. (Photocopies) | ✓ | |
| 15 | Assignment Questions and Solutions | ✓ | |
| 16 | Previous University Question Papers | ✓ | |
| 17 | Result Analysis | ✓ | |
| 18 | Feedback From Students | ✓ | |
| 19 | Course Exit Survey | | |
| 20 | CO Attainment for All Mids. | ✓ | |
| 21 | Remedial Action. | | |

USHA V



Department of Electrical & Electronics Engineering

(Name)

(Signature)

Department/Program-EEE

Vision of the Institute

To be among the best of the institutions for engineers and technologists with attitudes, skills and knowledge and to become an epicenter of creative solutions.

Mission of the Institute

To achieve and impart quality education with an emphasis on practical skills and social relevance.

Vision of the Department

To impart technical knowledge and skills required to succeed in life, career and help society to achieve self sufficiency.

Mission of the Department

- To become an internationally leading department for higher learning.
- To build upon the culture and values of universal science and contemporary education.
- To be a center of research and education generating knowledge and technologies which lay groundwork in shaping the future in the fields of electrical and electronics engineering.
- To develop partnership with industrial, R&D and government agencies and actively participate in conferences, technical and community activities.

Program Educational Objectives:

This education is meant to prepare our students to thrive and to lead. In their careers, our graduates:

1. Will have successful technical or professional careers, including supportive and leadership roles on multidisciplinary teams.
2. Will acquire, use and develop skills required for effective professional practices.
3. Will acquire the holistic education necessary to be a responsible member of society.
4. Engage in life-long learning to remain current in their profession and be leaders in our technological society



Department of Electrical & Electronics Engineering

Programme Learning Outcomes:

Students in the Electrical and Electronics Engineering program should, at the time of their graduation, be in possession of:

- a. Ability to apply knowledge of mathematics, science, and engineering.
- b. Ability to design and conduct experiments, as well as to analyze and interpret data.
- c. Ability to design a system, component, or process to meet desired needs within realistic constraints such as economic, environmental, social, political, ethical, health and safety, manufacturability, and sustainability.
- d. Ability to function on multi-disciplinary teams.
- e. Ability to identify, formulate, and solve engineering problems.
- f. Understanding of professional and ethical responsibility.
- g. Ability to communicate effectively.
- h. Broad education necessary to understand the impact of engineering solutions in a global, economic, environmental, and societal context.
- i. Recognition of the need for, and an ability to engage in life-long learning.
- j. Knowledge of contemporary issues.
- k. Ability to utilize experimental, statistical and computational methods and tools necessary for engineering practice.
- l. Graduates will demonstrate an ability to design electrical and electronic circuits, power electronics, power systems, electrical machines analyze and interpret data and also an ability to design digital and analog systems and programming them.

Name of the Course: High Voltage Engineering

Course Objectives:

1. To provide students importance of high voltage engineering.
2. To familiarize students with different dielectric materials and their break down mechanisms.
3. To give awareness of generation & measurement of high voltage and currents.
4. To impart the knowledge of insulation co-ordination.
5. To provide information on testing of electrical apparatus.



Course Outcomes:

Student will be able to;

1. Understand the importance of insulation providing for the high voltage equipment.
2. Understand the different methods of breakdown mechanisms that occur on application of high voltages.
3. Get the knowledge of different methods & techniques of generation and measurement of high voltages & currents of AC, DC and Impulse.
4. Discriminate the advantages and limitations of high voltage equipment used in the transmission system.
5. Get the awareness of the importance of testing of materials and apparatus

Assessment methods:

1. Regular attendance to classes.
2. Mid exam/Main exam.
3. Written class tests clearly linked to learning objectives
4. Classroom assessment techniques like tutorial sheets and assignments.
5. Seminars.

1. Program Educational Objectives(PEOs)-Program Outcomes(POs) Relationship Matrix (Indicate the relationships by mark "X")

| P-Outcomes | a | b | c | d | e | f | g | h | i | J | K | l |
|------------|---|---|---|---|---|---|---|---|---|---|---|---|
| 1 | H | M | M | H | H | | | H | H | H | H | H |
| 2 | H | H | H | H | H | | | M | M | M | H | H |
| 3 | | H | M | H | | M | M | H | M | H | | |
| 4 | | | | H | | | | | M | H | | H |



Department of Electrical & Electronics Engineering

2. Course Objectives-Program Outcomes (POs) Relationship Matrix (Indicate the relationships by mark "X")

| Cos/P-Outcomes | a | b | c | d | e | f | g | h | i | j | k | l |
|----------------|---|---|---|---|---|---|---|---|---|---|---|---|
| 1 | H | | M | | M | H | H | H | M | M | M | |
| 2 | H | M | H | | H | H | H | H | | | M | M |
| 3 | H | H | H | | M | H | H | H | | | | M |
| 4 | H | H | H | H | M | H | H | H | M | M | M | M |
| 5 | H | H | H | | H | H | H | H | M | | | |

3. Program Educational Objectives (PEOs)-Course Outcomes Relationship Matrix (Indicate the relationships by mark "X")

| P-Objectives (PEOs) | 1 | 2 | 3 | 4 |
|---------------------|---|---|---|---|
| Course-Outcomes | | | | |
| 1 | | H | H | X |
| 2 | H | H | M | M |
| 3 | H | | | |
| 4 | | M | M | M |
| 5 | | H | H | M |



COURSE OBJECTIVES

Academic Year : 2018-2019

Semester : I

Name of the Program: B.TechElectrical..... Year:IV.... Section: A&B

Course/Subject: High Voltage Engineering..... Course Code: **GR15A4147**

Name of the Faculty: Usha VDept.: ...EEE...Designation: ASST.PROFESSOR.

The objectives of the subject are,

| S.No | Objectives |
|------|--|
| 1 | To provide students importance of high voltage engineering |
| 2 | To familiarize students with different dielectric materials and their break down mechanisms. |
| 3 | To give awareness of generation & measurement of high voltage and currents |
| 4 | To impart the knowledge of insulation co-ordination. |
| 5 | To provide information on testing of electrical apparatus |

Signature of HOD

Signature of faculty

Date:



COURSE OUTCOMES

Academic Year : 2018-2019

Semester : I

Name of the Program: B.TechElectrical..... Year:IV.... Section: A&B

Course/Subject: High Voltage Engineering..... Course Code: **GR15A4147**

Name of the Faculty: Usha VDept.: ...EEE...Designation: ASST.PROFESSOR.

The expected outcomes of the Course/Subject are: Student will be able to

| S.No | Outcomes |
|------|---|
| 1 | Understand the importance of insulation providing for the high voltage equipment. |
| 2 | Understand the different methods of breakdown mechanisms that occur on application of high voltages |
| 3 | Get the knowledge of different methods & techniques of generation and measurement of high voltages & currents of AC, DC and Impulse |
| 4 | Discriminate the advantages and limitations of high voltage equipment used in the transmission system. |
| 5 | Get the awareness of the importance of testing of materials and apparatus |

Signature of HOD

Signature of faculty



ACADEMIC CALENDAR
Academic Year 2018-19

III & IV B.TECH – FIRST SEMESTER

| S. No. | EVENT | PERIOD | DURATION |
|--------|---|---------------------------------|-----------------------|
| 1 | 1 st Spell of Instructions | 02-07-2018 to 01-09-2018 | 9 Weeks |
| 2 | 1 st Mid-term Examinations | 03-09-2018 to 05-09-2018 | 3 Days |
| 3 | 2 nd Spell of Instructions | 06-09-2018 to 24-10-2018 | 7 Weeks |
| 4 | 2 nd Mid-term Examinations | 25-10-2018 to 27-10-2018 | 3 Days |
| 5 | Preparation | 29-10-2018 to 06-11-2018 | 1 Week 3 Days |
| 6 | End Semester Examinations (Theory/ Practicals) Regular/Supplementary | 08-11-2018 to 08-12-2018 | 4 Weeks 3 Days |
| 7 | Commencement of Second Semester, A.Y 2018-19 | 10-12-2018 | |

2018-19 I sem Subject allocation sheet

| IV YEAR(GR15) | Section-A | Section-B |
|--|-----------|--------------|
| Power Semiconductor Drives | YSV | Dr DGP |
| Power System Operation & Control | Dr JSD | Dr JSD |
| High Voltage DC Transmission Systems | MRE | Dr SVJK |
| Electrical Distribution Systems (PE-3) | VVSM | |
| High Voltage Engineering (PE-3) | VUR | |
| Soft Computing Techniques (OE-3) | RAK | RAK |
| DSP based Electrical Lab | AVK/DKK | AVK/DKK |
| Power Systems Simulation Lab | VVSM/ GSR | VVSM/ GSR |
| Power Electronic Drives Lab | MP/GBR | MP/GBR |



GOKARAJU RANGARAJU
INSTITUTE OF ENGINEERING AND TECHNOLOGY

Department of Electrical & Electronics Engineering

| Day/Hour | 10:00-10:50 | 10:50-11:40 | 11:40-12:30 | 12:30-1:00 | 1:00-1:45 | 1:45-2:30 | 2:30-3:15 | 3:15-4:00 |
|-----------|-------------|-------------|-------------|--------------|--------------------------|-----------|-----------|-----------|
| MONDAY | HVDCT | PSD | PSD | BREAK | PSS Lab / DSP Lab A1 /A2 | | | |
| TUESDAY | SCT | SCT | EDS/HVE | | PED Lab / PSS Lab A1 /A2 | | | |
| WEDNESDAY | EDS/HVE | SCT | SCT | | DSP Lab / PED Lab A1 /A2 | | | |
| THURSDAY | EDS/HVE | PSOC | PSOC | | PSD | PSD | HVDCT | HV/DCT |
| FRIDAY | HVDCT | HVDCT | EDS/HVE | | PSOC | PSOC | SCT | SCT |
| SATURDAY | HVDCT | EDS/HVE | EDS/HVE | | PSOC | PSOC | PSD | PSD |

Note: As HVE is Elective,,above time table is same for both A & B Sections



HIGH VOLTAGE ENGINEERING
(Professional Elective-III)

IV Year I Sem

Course Code: GR15A4147

L T P C
3 1 0 4

UNIT I

Introduction to High Voltage Engineering: Electric Field Stresses, Gas / Vacuum as Insulator, Liquid Dielectrics, Solids and Composites, Estimation and Control of Electric Stress, Numerical methods for electric field Computation, Surge voltages, their distribution and control, Applications of insulating materials in transformer, rotating machines, circuit breakers, cable power capacitors and bushings.

UNIT II

Break Down in Dielectric Materials: Gases as insulating media, collision process, Ionization process, Townsend's criteria of breakdown in gases, Paschen's law. Liquid as Insulator, pure and commercial liquids, breakdown in pure and commercial liquids. Intrinsic breakdown, electro mechanical breakdown, thermal breakdown, breakdown of solid dielectrics in practice, Breakdown in composite dielectrics, solid dielectrics used in practice.

UNIT III

Generation & Measurement of High Voltages & Currents: Generation of High Direct Current Voltages, Generation of High alternating voltages, Generation of Impulse Voltages, Generation of Impulse currents, Tripping and control of impulse generators. Measurement of High Direct Current voltages, Measurement of High Voltages alternating and impulse, Measurement of High Currents direct, alternating and Impulse, Oscilloscope for impulse voltage and current measurements.

UNIT IV

Over Voltages & Insulation Co-Ordination: Natural causes for over voltages — Lightning phenomenon, over Voltage due to switching surges, systems faults and other abnormal conditions, Principles of insulation Coordination on high voltage and Extra High Voltage power systems.

UNIT V

Testing Of Materials & Electrical Apparatus: Measurement of D.C Resistivity, Measurement of Dielectric Constant and loss factor, Partial discharge measurements. Testing of Insulators and bushings, Testing of Insulators and circuit breakers, testing of cables, Testing of Transformers, Testing of Surge Arresters, and Radio Interference measurements.

TEXT BOOKS

1. High Voltage Engineering, M.S.Naidu and V. Kamaraju, TMH Publications.
2. High Voltage Engineering, C.L.Wadhwa, New Age International (P) Limited.

REFERENCES

1. High Voltage Engineering: Fundamentals, E.Kuffel, W.S.Zaengi, J.Kuffel by Elsevier.
2. High Voltage Insulation Engineering, Ravindra Arora, Wolfgang Mosch, New Age International (P) Limited.



GUIDELINES TO STUDY THE COURSE / SUBJECT

Academic Year : 2018-2019

Semester : I

Name of the Program: B.TechElectrical..... Year:IV.... Section: A&B

Course/Subject: High Voltage Engineering..... Course Code: **GR15A4147**

Name of the Faculty: Usha VDept.: ...EEE...Designation: ASST.PROFESSOR.

Course Design and Delivery System (CDD):

- The Course syllabus is written into number of learning objectives and outcomes.
- These learning objectives and outcomes will be achieved through lectures, assessments, assignments, seminars, presentations, etc.
- Every student will be given an assessment plan, criteria for assessment, scheme of evaluation and grading method.
- The Learning Process will be carried out through assessments of Knowledge, Skills and Attitude by various methods and the students will be given guidance to refer to the text books, reference books, journals, etc.

The faculty be able to –

- Understand the psychology of students
- Develop instructional objectives for a given topic
- Prepare course, unit and lesson plans
- Use appropriate teaching and learning aids
- Plan and deliver lectures effectively
- Provide feedback to students using various methods of Assessments and tools of Evaluation
- Act as a guide, advisor, counselor, facilitator, motivator and not just as a teacher alone



COURSE SCHEDULE

Academic Year : 2018-2019

Semester : I

Name of the Program: B.TechElectrical..... Year:IV.... Section: A&B

Course/Subject: High Voltage Engineering..... Course Code: **GR15A4147**

Name of the Faculty: Usha VDept.: ...EEE...Designation: ASST.PROFESSOR

The Schedule for the whole Course / Subject is:

| S. No. | Description | Duration (Date) | | Total No. Of Periods |
|--------|-------------|-----------------|------------|----------------------|
| | | From | To | |
| 1. | Unit-1 | 3/7/2018 | 18/7/2018 | 8 |
| 2. | Unit-2 | 19/7/2018 | 22/8/2018 | 14 |
| 3. | Unit-3 | 23/8/2018 | 21/9/2018 | 16 |
| 4.. | Unit-4 | 22/9/2018 | 04/10/2018 | 12 |
| 5. | Unit-5 | 05/10/2018 | 23/10/2018 | 12 |

Total No. of Instructional periods available for the course:62.... Hours / Period



Schedule of instructions

COURSE PLAN

Academic Year : 2018-2019

Semester : I

Name of the Program: B.TechElectrical..... Year:IV.... Section:A&B

Course/Subject: High Voltage Engineering..... Course Code: **GR15A4147**

Name of the Faculty: Usha VDept.: ...EEE...Designation: ASST.PROFESSOR

| S.No | Unit No | Date | Topic |
|------|---------|-----------------------|--|
| 1 | 1 | 3/7/2018 & 4/7/2018 | Introduction to High Voltage Engineering: Electric Field Stresses |
| 2 | 1 | 5/7/2018 & 6/7/2018 | Gas / Vacuum as Insulator, Liquid Dielectrics, Solids and Composites |
| 3 | 1 | 7/7/2018 & 10/7/2018 | Estimation and Control of Electric Stress |
| 4 | 1 | 11/7/2018 & 12/7/2018 | Numerical methods for electric field Computation |
| 5 | 1 | 13/7/2018 & 14/7/2018 | Surge voltages, their distribution and control |
| 6 | 1 | 17/7/2018 & 18/7/2018 | Applications of insulating materials in transformer, rotating machines, circuit breakers, cable power capacitors and bushings. |
| 7 | 2 | 19/7/2018 & 20/7/2018 | Break Down in Dielectric Materials: Gases as insulating media, collision process |
| 8 | 2 | 21/7/2018 & 24/7/2018 | Ionization process |
| 9 | 2 | 25/7/2018 & 26/7/2018 | Townsend's criteria of breakdown in gases |
| 10 | 2 | 27/7/2018 & 28/7/2018 | Paschen's law |
| 11 | 2 | 31/7/2018 & 1/8/2018 | Liquid as Insulator, pure and commercial liquids |
| 12 | 2 | 2/8/2018 & 3/8/2018 | breakdown in pure and commercial liquids |
| 13 | 2 | 4/8/2018 & 7/8/2018 | Intrinsic breakdown |
| 14 | 2 | 8/8/2018 & 9/8/2018 | electro mechanical breakdown |
| | | | |



Department of Electrical & Electronics Engineering

| | | | |
|----|---|--------------------------|---|
| | | | |
| 15 | 2 | 10/8/2018 & 11/8/2018 | thermal breakdown |
| 16 | 2 | 14/8/2018 & 16/8/2018 | Breakdown of solid dielectrics in practice |
| 17 | 2 | 17/8/2018 & 18/8/2018 | Breakdown in composite dielectrics |
| 18 | 2 | 21/8/2018 & 22/8/2018 | solid dielectrics used in practice |
| 19 | 3 | 23/8/2018 & 24/8/2018 | Generation of High Direct Current Voltages |
| 20 | 3 | 25/8/2018 & 28/8/2018 | Generation of High alternating voltages |
| 21 | 3 | 29/8/2018 & 30/8/2018 | Generation of Impulse Voltages |
| 22 | 3 | 31/8/2018 & 4/9/2018 | Generation of Impulse currents |
| 23 | 3 | 5/9/2018 & 6/9/2018 | Tripping and control of impulse generators |
| 24 | 3 | 7/9/2018 & 8/9/2018 | Measurement of High Direct Current voltages |
| 25 | 3 | 11/9/2018 & 12/9/2018 | Measurement of High Voltages alternating and impulse |
| 26 | 3 | 14/9/2018 & 15/9/2018 | Measurement of High Currents direct |
| 27 | 3 | 18/9/2018 & 19/9/2018 | Measurement of High alternating and Impulse |
| 28 | 3 | 20/9/2018 & 21/9/2018 | Oscilloscope for impulse voltage and current measurements |
| 29 | 4 | 22/9/2018 & 25/9/2018 | Over Voltages & Insulation Co-Ordination |
| 30 | 4 | 26/9/2018 & 27/9/2018 | Natural causes for over voltages -Lightning phenomenon |
| 31 | 4 | 28/9/2018 & 29/9/2018 | over Voltage due to switching surges |
| 32 | 4 | 03-10-18 | systems faults and other abnormal conditions |
| 33 | 4 | 04-10-18 | Principals of insulation Coordination on high voltage and Extra High Voltage power systems. |
| 34 | 5 | 05-10-18 | Testing Of Materials & Electrical Apparatus: Measurement of D.C Resistivity |
| 35 | 5 | 06-10-18 | Measurement of Dielectric Constant and loss factor |
| 36 | 5 | 09-10-18 | Partial discharge measurements |
| 37 | 5 | 10-10-18 | Testing of Insulators and bushings |
| 38 | 5 | 11-10-18 | Testing of Isolators and circuit breakers |
| 39 | 5 | 12-10-18 | Testing of cables |
| 40 | 5 | 13-10-18 | Testing of Transformers |
| 41 | 5 | 16-10-18 | Testing of Surge Arresters |
| 42 | 5 | 23-10-18 | Radio Interference measurements. |
| 43 | | 23-10-18 | Revision |



COURSE COMPLETION STATUS

Academic Year : 2018-2019

Semester : I

Name of the Program: B.TechElectrical..... Year:IV.... Section:A&B

Course/Subject: High Voltage Engineering..... Course Code: **GR15A4147**

Name of the Faculty: Usha VDept.: ...EEE...Designation: ASST.PROFESSOR

| Units | Remarks | No. of Objectives | No. of Outcomes |
|--------------|------------------------|--------------------------|------------------------|
| Unit 1 | Successfully Completed | 1 | 1 |
| Unit 2 | Successfully Completed | 1 | 1 |
| Unit 3 | Successfully Completed | 1 | 1 |
| Unit 4 | Successfully Completed | 1 | 1 |
| Unit 5 | Successfully Completed | 1 | 1 |



CO Cognitive level Mapping

| COs | Cognitive Learning Levels | | | | | |
|-----|---------------------------|---|---|---|---|---|
| | 1 | 2 | 3 | 4 | 5 | 6 |
| 1 | | | √ | | | |
| 2 | | √ | | | | |
| 3 | | | | √ | | |
| 4 | | | | | | √ |
| 5 | | | | | √ | |
| 6 | √ | | | | | |
| 7 | √ | | | | | |

Cognitive Learning Levels

CLL 1: Remembering

CLL 2: Understanding

CLL 3: Applying

CLL 4: Analyzing

CLL 5: Evaluating

CLL 6: Creating



Academic Year: **2018-19**

Year: **IV**

Semester: **I**

MID Exam – I (Descriptive)
HIGH VOLTAGE ENGINEERING
Code: GR15A4147

Date: 27/09/2018

Duration: **90 min**

Max Marks: **15**

Note: Answer any three questions. All questions carry equal marks.

| | | | |
|----|---|-----|----------|
| 1. | What is meant by ionization, Explain the Breakdown procedure in gaseous dielectrics? | [5] | [CO-1,2] |
| 2. | Briefly Explain the Townsend's criteria of breakdown in gases? And explain the paschen's law. | [5] | [CO-1,2] |
| 3. | Explain the applications of insulating materials and illustrate with examples. | [5] | [CO-1,2] |
| 4. | Explain the Thermal Breakdown in solid dielectrics. | [5] | [CO-1,2] |



Academic Year: **2018-19**

Year: **IV**

Semester: **I**

MID Exam – II (Descriptive)
HIGH VOLTAGE ENGINEERING
Code: GR15A4147

Date: 26/10/2018

Duration: **90 min**

Max Marks: **15**

Note: Answer any three questions. All questions carry equal marks.

| | | | |
|----|---|-----|--------|
| 5. | Briefly Explain the Generation of High alternating voltages | [5] | [CO-3] |
| 6. | Explain the Tripping and control of impulse generators | [5] | [CO-3] |
| 7. | Explain the Principals of insulation Coordination on high voltage power systems | [5] | [CO-4] |
| 8. | Explain the Measurement of D.C Resistivity | [5] | [CO-5] |



EVALUATION STRATEGY

Academic Year : 2018-2019

Semester : I

Name of the Program: B.TechElectrical..... Year:IV.... Section: A&B

Course/Subject: High Voltage Engineering..... Course Code: **GR15A4147**

Name of the Faculty: Usha VDept.: ...EEE...Designation: ASST.PROFESSOR

1. TARGET:

A) Percentage for pass:95

B) Percentage of class:90

2. COURSE PLAN & CONTENT DELIVERY

Teaching of Units/Lessons by lectures, exercises, solving numerical problems, or by assignments, etc.)

3. METHOD OF EVALUATION

- 3.1 Assignments/Seminars
- 3.2 Quiz
- 3.3 Semester/End Examination
- 3.4 Mid Exams

4. List out any new topic(s) or any innovation you would like to introduce in teaching the subjects in this Semester.

focus on Research in the **Advanced High Voltage Engineering**



Assignment Questions

1. State and explain Paschen's law. How do you account for the minimum voltage for breakdown under a given „p*d“ condition?
2. Explain thermal breakdown in solid dielectrics and its significance.
3. Explain streamer theory breakdown in gases.
4. Describe the current growth phenomenon in a gas subjected to uniform electric fields.
5. Describe with a neat sketch the working of a Van de Graaff generator. What are the factors that limit the maximum voltage obtained?
6. What are the basic requirements of a lightning arrester? Differentiate between i) lightning arrester and a lightning conductor, and (ii) a surge diverter and a surge absorber



GOKARAJU RANGARAJU
INSTITUTE OF ENGINEERING AND TECHNOLOGY

Department of Electrical & Electronics Engineering

Gokaraju Rangaraju Institute of Engineering and Technology

Department of Electrical and Electronics Engineering

B.Tech EEE IV YEAR- I SEM RESULT ANALYSIS OF 2015-2019 BATCH

ACADEMIC YEAR 2018-2019

TOTAL NO. OF STUDENTS REGISTERED = 140

| Subject | Total No. of students appeared | No. of students passed | No. of students failed | Grade Points | | | | | | | |
|---------|--------------------------------|------------------------|------------------------|--------------|----|----|----|----|----|----|-----------------|
| | | | | < 5 | 5 | 6 | 7 | 8 | 9 | 10 | Pass percentage |
| PSD | 140 | 132 | 08 | 02 | 01 | 04 | 06 | 30 | 40 | 49 | 94.28% |
| PSOC | 140 | 131 | 09 | 01 | 09 | 08 | 18 | 25 | 48 | 22 | 93.57% |
| HVDC TT | 140 | 132 | 08 | 16 | 18 | 16 | 17 | 38 | 22 | 05 | 94.28% |
| EDS | 140 | 137 | 03 | 01 | 05 | 05 | 10 | 29 | 19 | 22 | 97.85% |
| DSPBEL | 140 | 139 | 01 | 29 | 05 | 03 | 05 | 10 | 25 | 62 | 99.28% |
| PSSL | 140 | 140 | 00 | 09 | 03 | 03 | 09 | 23 | 30 | 63 | 100% |
| PEADL | 140 | 139 | 01 | 00 | 02 | 12 | 27 | 21 | 17 | 60 | 99.28% |
| HVE | 140 | 139 | 01 | 01 | 01 | 02 | 04 | 08 | 18 | 11 | 99.28% |
| SCT | 140 | 132 | 08 | 01 | 01 | 06 | 09 | 21 | 29 | 65 | 94.28% |

Overall pass (passed in all subjects) = 128/ 140(91%)



Faculty

| | |
|------------------------------------|--------------------------------|
| Power Semiconductor Drives | Dr.D G Padhan /Y Satyavani |
| Power System Operation And Control | Dr. J. Sridevi |
| HVDC Transmission | Dr Jayaram Kumar / Mrekha |
| Electrical Distribution Systems | VVS Madhuri |
| DSP Based Electrical Lab | A Vinay Kumar |
| Power System Simulation Lab | G Sandhya Rani / V V S Madhuri |
| Power Electronics And Drives Lab | M Prashanth /G Bhaskar Rao |
| High Voltage Engineering | V Usha Rani |
| Soft Computing Techniques | R Anil Kumar |



CO Attainments

IV B.Tech-HVE CO ATTAINMENT-Mid-I

| SNO | CO1(5) | CO2(10) | CO3 | CO4 | CO5 |
|-----|--------|---------|-----|-----|-----|
| 1 | 5 | 10 | | | |
| 2 | 5 | 10 | | | |
| 3 | 5 | 10 | | | |
| 4 | 5 | 10 | | | |
| 5 | 5 | 10 | | | |
| 6 | 5 | 10 | | | |
| 7 | 5 | 10 | | | |
| 8 | 5 | 6 | | | |
| 9 | 5 | 10 | | | |
| 10 | 5 | 10 | | | |
| 11 | 5 | 10 | | | |
| 12 | 5 | 10 | | | |
| 13 | 5 | 10 | | | |
| 14 | 5 | 10 | | | |
| 15 | 5 | 8 | | | |
| 16 | 5 | 10 | | | |
| 17 | 5 | 10 | | | |
| 18 | 5 | | | | |
| 19 | 5 | 9 | | | |
| 20 | 5 | 10 | | | |
| 21 | 5 | 10 | | | |
| 22 | 5 | 10 | | | |
| 23 | 5 | 3 | | | |
| 24 | 5 | 10 | | | |
| 25 | 5 | 7 | | | |
| 26 | 5 | 3 | | | |
| 27 | 5 | 8 | | | |
| 28 | 5 | 10 | | | |
| 29 | 5 | 10 | | | |
| 30 | 5 | 10 | | | |
| 31 | 5 | 10 | | | |
| 32 | 5 | 8 | | | |
| 33 | 4 | 5 | | | |
| 34 | 1 | 5 | | | |
| 35 | 3 | 5 | | | |
| 36 | 5 | 10 | | | |
| 37 | 5 | 2 | | | |
| 38 | 5 | 10 | | | |



GOKARAJU RANGARAJU
INSTITUTE OF ENGINEERING AND TECHNOLOGY

Department of Electrical & Electronics Engineering

| | | | | | |
|--|-----------|-------------|--|--|--|
| 39 | 5 | 10 | | | |
| 40 | 5 | 10 | | | |
| 41 | 5 | 10 | | | |
| 42 | 5 | 10 | | | |
| 43 | 5 | 9 | | | |
| 44 | 5 | 10 | | | |
| 45 | 5 | 10 | | | |
| 46 | 5 | 10 | | | |
| No.of students attempted | 46 | 45 | | | |
| Total marks | 223 | 398 | | | |
| %Attempted | 100 | 97.8 | | | |
| Average marks Coi | 4.85 | 8.84 | | | |
| Evaluation of course outcome attainment % | 97 | 88.4 | | | |

| | |
|-----|-------------|
| | % |
| Co1 | 97 |
| Co2 | 88.4 |
| Co3 | |
| Co4 | |
| Co5 | |



IV B.Tech-HVE CO ATTAINMENT-Mid-II

| SNO | CO1(5) | CO2(10) | CO3 | CO4 | CO5 |
|-----|--------|---------|-----|-----|-----|
| 1 | | | 5 | 5 | 5 |
| 2 | | | 5 | 5 | 5 |
| 3 | | | 5 | | |
| 4 | | | 5 | 5 | 5 |
| 5 | | | 5 | 5 | 5 |
| 6 | | | 5 | 5 | 5 |
| 7 | | | 5 | 5 | 5 |
| 8 | | | 5 | 5 | 5 |
| 9 | | | 5 | 5 | 5 |
| 10 | | | 5 | 5 | 5 |
| 11 | | | 5 | 5 | 5 |
| 12 | | | 5 | 5 | 5 |
| 13 | | | 5 | 5 | 5 |
| 14 | | | 5 | 5 | 3 |
| 15 | | | 5 | 5 | |
| 16 | | | 5 | 5 | 5 |
| 17 | | | 5 | 5 | 5 |
| 18 | | | 2 | | |
| 19 | | | 5 | 5 | 5 |
| 20 | | | 5 | 5 | 5 |
| 21 | | | 5 | 5 | 4 |
| 22 | | | 5 | 5 | 4 |
| 23 | | | 5 | 5 | 4 |
| 24 | | | 5 | 5 | 5 |
| 25 | | | 5 | 5 | 5 |
| 26 | | | 5 | 4 | 3 |
| 27 | | | 5 | 5 | 5 |
| 28 | | | 5 | 5 | 5 |
| 29 | | | 5 | 5 | 4 |
| 30 | | | 5 | 5 | 5 |
| 31 | | | 5 | 5 | 5 |
| 32 | | | 5 | 5 | |
| 33 | | | 5 | 1 | |
| 34 | | | 5 | 5 | 5 |
| 35 | | | 5 | 5 | 5 |
| 36 | | | 5 | 5 | 5 |
| 37 | | | 5 | 5 | 5 |
| 38 | | | 5 | 5 | 5 |
| 39 | | | 5 | 5 | 5 |
| 40 | | | 5 | 5 | 5 |
| 41 | | | 5 | 5 | 5 |
| 42 | | | 5 | 5 | 5 |
| 43 | | | 5 | 5 | 5 |
| 44 | | | 5 | 5 | 4 |



GOKARAJU RANGARAJU
INSTITUTE OF ENGINEERING AND TECHNOLOGY

Department of Electrical & Electronics Engineering

| | | | | | |
|--|----|--|-------------|-------------|------|
| | | | | | |
| | 45 | | 5 | 5 | 5 |
| No.of students attempted | | | 45 | 43 | 40 |
| Total marks | | | 222 | 210 | 191 |
| %Attempted | | | 100 | 95.5 | 88.9 |
| Average marks Coi | | | 4.93 | 4.88 | 4.78 |
| Evaluation of course outcome attainment % | | | 98.6 | 97.6 | 95.6 |

%

| | |
|-----|-------------|
| Co1 | |
| Co2 | |
| Co3 | 98.6 |
| Co4 | 97.6 |
| Co5 | 95.6 |



RUBRICS OBJECTIVE: Work effectively with others

STUDENT OUTCOME: Ability to function in a multi-disciplinary team

| S.No. | Student Name | Performance Criteria | Unsatisfactory | Developing | Satisfactory | Exemplary | Score |
|-------|----------------------------|--|---|---|--|--|-------|
| | | | 1 | 2 | 3 | 4 | |
| 1. | B Tarun Teja 15241A0204 | Research & Gather Information | Does not collect any information that relates to the topic. | Collects very little information--some relates to the topic | Collects some basic information --most relates to the topic. | Collects a great deal of information --all relates to the topic. | 3 |
| | | Fulfill team role's duty | Does not perform any duties of assigned team role. | Performs very little duties. | Performs nearly all duties. | Performs all duties of assigned team role. | 3 |
| | | Share Equally | Always relies on others to do the work. | Rarely does the assigned work-- often needs reminding. | Usually does the assigned work-- rarely needs reminding | Always does the assigned work without having to | 4 |
| | | Listen to other team mates | Is always talking-- never allows anyone else to speak. | Usually doing most of the talking-- rarely allows | Listens, but sometimes talks too much. | Listens and speaks a Fair amount . | 4 |

| S.No. | Student Name | Performance Criteria | Unsatisfactory | Developing | Satisfactory | Exemplary | Score |
|-------|-----------------------------|--|---|---|--|--|-------|
| | | | 1 | 2 | 3 | 4 | |
| 1. | Sai sandeepya 15241A0244 | Research & Gather Information | Does not collect any information that relates to the topic. | Collects very little information--some relates to the topic | Collects some basic information --most relates to the topic. | Collects a great deal of information --all relates to the topic. | 3 |
| | | Fulfill team role's duty | Does not perform any duties of assigned team role. | Performs very little duties. | Performs nearly all duties. | Performs all duties of assigned team role. | 3 |
| | | Share Equally | Always relies on others to do the work. | Rarely does the assigned work-- often needs reminding. | Usually does the assigned work-- rarely needs reminding | Always does the assigned work without having to | 3 |
| | | Listen to other team mates | Is always talking-- never allows anyone else to speak. | Usually doing most of the talking-- rarely allows speak | Listens, but sometimes talks too much. | Listens and speaks a Fair amount | 3 |

Avg Score:3

| S.No. | Student Name | Performance Criteria | Unsatisfactory | Developing | Satisfactory | Exemplary | Score |
|-------|-------------------------|--|---|--|--|---|-------------|
| | | | 1 | 2 | 3 | 4 | |
| 1. | M Anuroop 15241A02A0 | Research & Gather Information | Does not collect any information that relates to the topic. | Collects very little information--some relates to the topic | Collects some basic information--most | Collects a great deal of information--all relates to the topic. | 2 |
| | | Fulfill team role's duty | Does not perform any duties of assigned team role | Performs very little duties. | Performs nearly all duties. | Performs all duties of assigned team role. | 2 |
| | | Share Equally | Always relies on others to do the work. | Rarely does the assigned work--often needs reminding. | Usually does the assigned work--rarely needs reminding | Always does the assigned work without having | 3 |
| | | Listen to other team mates | Is always talking--never allows anyone else to speak. | Usually doing most of the talking--rarely allows speak others to | Listens, but sometimes talks too much. | Listens and speaks a Fair amount. | 2 |
| | | | | | | | 2.25 |

Gokaraju Rangaraju Institute of Engineering & Technology

(Autonomous)

Bachupally, Kukatpally, Hyderabad - 500090

No. **240120** ROLL NO.:

| | | | | | | | | | |
|---|---|---|---|---|---|---|---|---|---|
| 1 | 5 | 2 | 4 | 1 | A | 0 | 2 | 4 | 4 |
|---|---|---|---|---|---|---|---|---|---|

CLASS & BRANCH EET-A

NAME Sai Sandeepa SUBJECT High Voltage Engineering

SIGNATURE OF THE INVIGILATOR [Signature] DATE: 26/10/2018

| | | |
|----------|--------------------------|--------------------------|
| SEMESTER | I | II |
| | <input type="checkbox"/> | <input type="checkbox"/> |

MID TERM EXAMINATION

| | | | | | | |
|-------|---|---|---|---|---|-------|
| Q.NO. | 1 | 2 | 3 | 4 | 5 | TOTAL |
| | a | b | a | b | a | |
| MARKS | | 4 | | 3 | | 12 |

START WRITING FROM HERE

Explain the Generation of high alternating

voltages.

High alternating voltages are generated in a very

efficient way. 5% of impedance is used in

resonance method. By generating high alternating

voltages the chance of getting faults reduces

lot. It is very use to generate high

alternating voltages. In generation of high

setting voltage, its always good to
certain amount of balance voltage
d current.

Timing Tripping and control of impulse generators.

Tripping:- Tripping is depend as a process in
for a certain amount of current is stopped
it is tripped. This process creates certain
level of instability in the process. Certain
amount of faults may also arises from this
cases.

level of impulse generator:-

control of impulse generator is a process
in which a certain amount of control
is achieved on the impulse generator.

in impulse ions it limits the amount of

It has many advantages. with this process
impulse generator does not face any fault or
short circuits. Such process increases efficiency.

(11) Explain the measurement of D.C resistivity.

D.C tests resistivity is depend as the value of
resistance for D.C that is offered in D.C.

The resistance offered to the flow of current

in D.C is due said to be D.C resistivity.

DC resistivity depends The measurement of D.C
resistivity depends on many factors. One of
such factors is the length, test material
of D.C and etc. Measurement of D.C resistivity
is very important aspect.

Bachupally, Kukatpally, Hyderabad - 500090

No. 240081

ROLL NO.: 15241A0204

CLASS & BRANCH

B.Tech 4th Year & EEE-A

NAME B. Tejun Teja

SUBJECT High Voltage Engineering

SIGNATURE OF THE INVIGILATOR

DATE: 26/10/2018

SEMESTER I II

I II

MID TERM EXAMINATION

| Q.NO. | 1 | | 2 | | 3 | | 4 | | 5 | | TOTAL |
|-------|---|---|---|---|---|---|---|---|---|---|-------|
| | a | b | a | b | a | b | a | b | a | b | |
| MARKS | | 5 | | | | | 5 | 5 | | | 15 |

START WRITING FROM HERE

Generation of high alternating voltages.

The voltage which is less than 300kV can be managed by using single transformers. When we need to increase the voltage level we need to connect the transformers in series. This system is not economical as they need to be installed and operated. There are more losses with this system. This problem can be overcome by cascading of transformers.

In this system the transformers are interlinked with their primary and secondary side coils. ∴ arrangement unit.

The circuit ...

a_1 - L.V winding
 ob_1 - H.V winding
 id_1 - measuring meter
 v_1 - input voltage
 v_2 - Output Voltage.

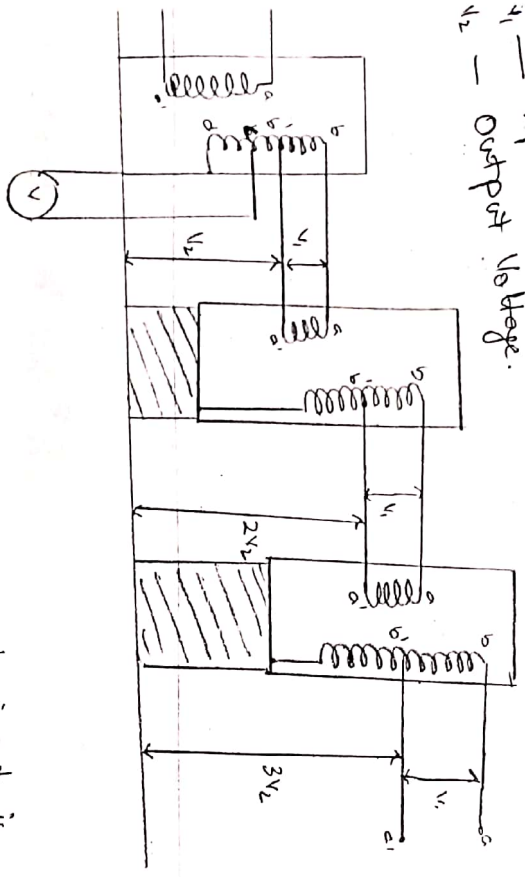

Cascading transformer the initial input is provided with v_1 and output v_2 is given as the input to the next transformer as low level winding. In is provided on a insulator. The meter is connected to measure the voltage. This low level winding is connected mutually with high level winding. In is connected mutually with next transformer. In acts as L.V winding for the next transformer. voltage is increased step by step by forward. $v_1, v_2, 2v_2, 3v_2, \dots$ If the system is

The first unit is provided directly and from the second unit, the insulator placed in the bottom behaves as a ground potential. The supply to this system is provided by using motor-generator set. This can be more efficient if the voltage regulator is used for supply which reduces the losses. As the motor and generator set have to drive more to achieve the required level. Resonant transformer can also be used in generator purpose which has many advantage over cascading transformer. The output of the resonant transformer is a pure sine wave and the output is accurate. It has a very low impedance less than 5% as it is one of the ideal condition. Short Circuit Capacity must be less than 1. and with stand the high frequency current if any faults occur in the system.

Measurement of DC Resistivity.

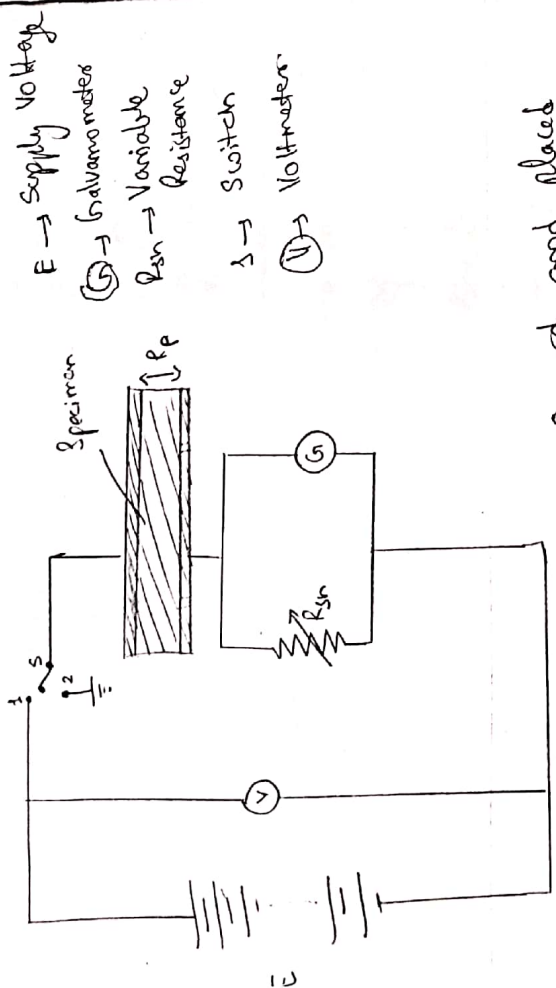

Specimen is taken with Guard and placed the circuit as shown above in the diagram. The Voltmeter is adjusted with the parallel resistance which is 1 to 10M Ω and can be varied. This resistance is set based on the operation with in galvanometer shows accurate sensitivity. The sensitivity of galvanometer is measured in μcm^2 . Sensitivity of the above circuit is 10^9 A/cm^2 . It can be increased by using a DC amplifier. The circuit at the position of galvanometer -

The Resistance 'R_p' has to be calculated which is given by.

$$R_p = \frac{V}{D \times G}$$

- D \rightarrow Deflection in galvanometer
- G \rightarrow measure of reading in galvanometer
- V \rightarrow input supply voltage

$$G = \left(\frac{V}{R_s}\right) \times \left(\frac{l}{A}\right) \times \left(\frac{1}{D_s}\right)$$

- R_s \rightarrow Resistance per unit system.
- D_s \rightarrow Deflections in the system meter
- V \rightarrow Supply Voltage.

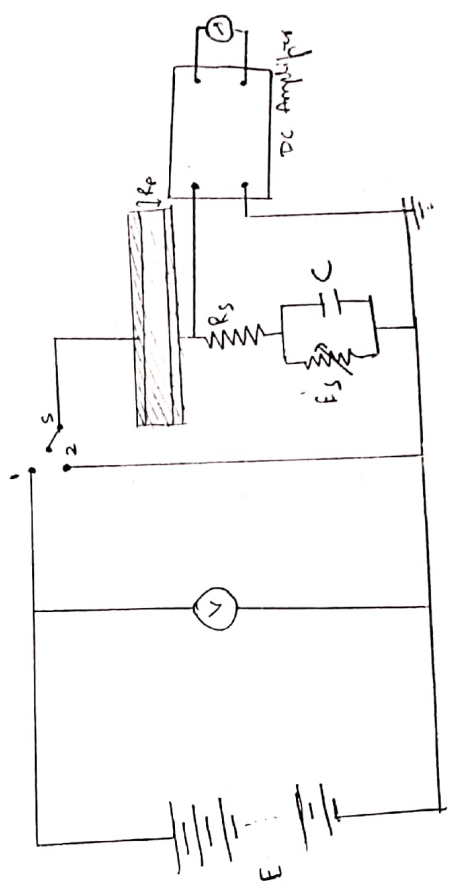

Measurement of DC Resistivity.

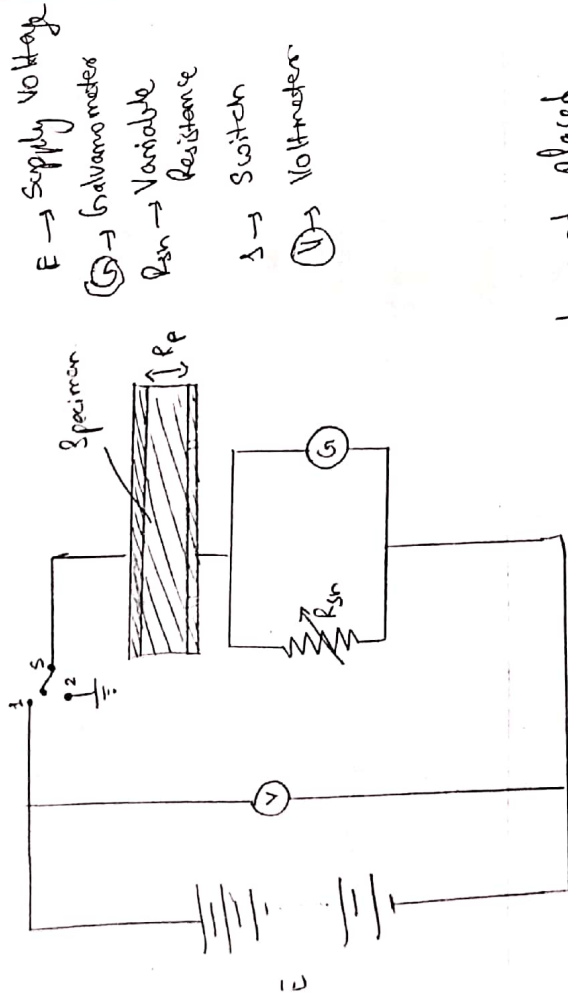

Specimen is taken with G and placed in the diagram. The circuit as shown above in the parallel resistances galvanometer is adjusted with the parallel resistances which is 1 to 10MΩ and can be varied. This resistance is set based on the operation with in galvanometer shows accurate sensitivity. The sensitivity of galvanometer is measured in A/cm^2 . Sensitivity of the above circuit is $10^{-9} A/cm^2$. Sensitivity can be increased by using a DC amplifier. The circuit at the position of galvanometer is 10^{-12} to $10^{-15} A/cm^2$.

The resistance 'R_p' has to be calculated which is given by:

$$R_p = \frac{V}{D \times I}$$

- D → Deflection in galvanometer
- G → measure of reading in galvanometer
- V → input supply voltage

∴ Thus

$$G = \left(\frac{V}{R_s} \right) \times \left(\frac{L}{A} \right) \times \left(\frac{1}{D_s} \right)$$

- R_s → Resistance per unit system.
- D_s → Deflections in the system meter
- V → Supply Voltage.

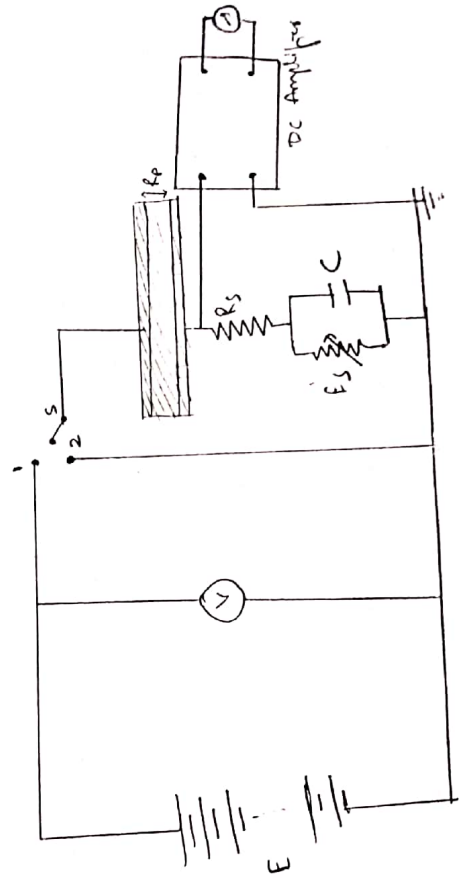

re measuring the galvanometer reading, the
 ch 'S' must be connected at position '2'. So that
 total residual current is discharged and the
 put is accurate. After some time a switch is
 orted to '1' position and the readings are taken.
 the circuit which is connected with dc amplifier
 comparatively best result. Initially the value must
 made null by adjusting the variable
 sistors e's. After the meter shows null reading,
 n by connecting the measuring equipment and
 ring the valve. The Volt-time graphs are
 own for the measurement.

Principals of Insulation Coordination on high voltage Power Systems.

every system must be provided with a proper
 sulation. As the system like transformer, circuit break,
 with gears are not having any protective device
 ipment inside them to protect from the
 ults and harmonics.
 A proper insulation must be provided to the
 system, as the equipments are very costly and
 lot of time to be installed which

can be replaced easily.

- In a substation for example all the materials insulation level must be noted and the basic insulation level (BIL) must be designed so that any damage in the system cannot affect the equipment.
- The materials selected as the protective equipment must be having low resistive path, allow the flow of high frequency, providing a discharge path for the high order harmonics.
- The lightning arresters ~~are~~ must be placed in the system for the protection ~~of~~ the lightning and any external disturbance.
- These materials must not allow the flow of power frequency components.
- They must be capable of differentiating between the normal and abnormal condition frequencies.
- The Volt-time curve of the protected equipment must be higher than the Volt-time curve of the protecting material.
- A proper (SIL) surge impedance level must be designed for the system.

Bachupally, Kukatpally, Hyderabad - 500090

Roll No: 240357 | 1 | 5 | 2 | 4 | 1 | A | 0 | 2 | A | 0

SS & BRANCH: IVth B.Tech. EEE - B

SEMESTER: I | II | SUBJECT: HVE

NATURE OF THE INVIGILATOR: [Signature] DATE: 24/10/18

SEMESTER: I | II | MID TERM EXAMINATION

| Q NO. | 1 | | 2 | | 3 | | 4 | | 5 | | TOTAL |
|-------|---|---|---|---|---|---|---|---|---|---|-------|
| | a | b | a | b | a | b | a | b | a | b | |
| MARKS | | 2 | | 2 | | 2 | | | | | 6 |

START WRITING FROM HERE

Why explain the generation of high alternating
waves.

Why the voltage is generated from the
aircore.

Stepup transformer is used under to increase
voltage at the alternating voltage.

Gokaraju Rangaraju Institute of Engineering & Technology
(Autonomous)

(12 Pages)

Bachupally, Kukatpally, Hyderabad - 500090

No. 213993 ROLL NO.:

| | | | | | | | | | |
|---|---|---|---|---|---|---|---|---|---|
| 1 | 5 | 2 | 4 | 1 | A | 0 | 2 | 1 | 4 |
|---|---|---|---|---|---|---|---|---|---|

CLASS & BRANCH EEE

NAME G. Sai Kumar SUBJECT High Voltage Engineering

SIGNATURE OF THE INVIGILATOR [Signature] DATE: 26/01/18

| | | | | | | | | | | | | |
|----------|-------------------------------------|--------------------------|----------------------|----|---|---|---|---|---|---|-------|--|
| SEMESTER | I | II | MID TERM EXAMINATION | | | | | | | | | |
| | <input checked="" type="checkbox"/> | <input type="checkbox"/> | I | II | 3 | 4 | 5 | | | | | |
| | a | b | a | b | a | b | a | b | a | b | TOTAL | |

| | | | | | | |
|-------|---|---|---|---|---|-------|
| Q.NO. | 1 | 2 | 3 | 4 | 5 | TOTAL |
| MARKS | a | b | a | b | a | b |

START WRITING FROM HERE

Ionization:

The process of producing electrons and +ve ions from neutral atoms is called as

Ionization.

"Ionization by collision" this can clearly explain

Procedure:

The breakdown of gaseous dielectrics

when the electrons move in gaseous medium .
 .1. Gaseous molecules and produce

consider two electrodes separated by a pressure gas, one is anode and other cathode.

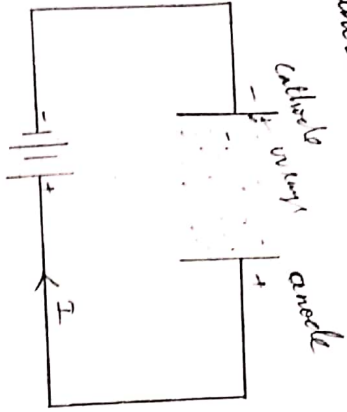

an electric field is applied across them electrons get active electrons start moving from cathode to anode in this process they collide with the gas molecules in collision with gaseous molecules new electrons are formed.



v) For more electrons to flow from cathode to anode external sources like W rays should be used.

v) The gaseous particle doesn't lose its electric property upto certain voltage and they resist the flow of current.

vii) After a certain high voltage the dielectric breaks and start conduction. This voltage is called as breakdown voltage.

24th Townsend's Law:

Townsend has given an empirical formula for the average current through dielectric during breakdown phenomenon.

$$I = I_0 e^{\alpha d}$$

(1 mark)

where $\alpha \rightarrow$ Townsend's primary ionization constant

$\gamma \rightarrow$ Townsend's secondary ionization constant

$d \rightarrow$ distance b/w electrodes

$I_0 \rightarrow$ initial current

'for breakdown current starts flowing

high dielectric i.e. $I \rightarrow \infty$

$$\Rightarrow 1 - \gamma (e^{\alpha d} - 1) = 0$$

$$\gamma (e^{\alpha d} - 1) = 1$$

$$\gamma e^{\alpha d} - \gamma = 1$$

the exponential term is very large

field γ ,

$$\therefore \gamma e^{\alpha d} = 1$$

'is Townsend's relation for breakdown

nonion. red on this he proposed is theories

if $\gamma e^{\alpha d} = 1$ then the breakdown is just finished, current starts flowing (i.e. acts as conductor)

if $\gamma e^{\alpha d} > 1$, then dielectric becomes conductor and production of electrons is very high

if $\gamma e^{\alpha d} < 1$, then no electrons are formed and dielectric acts as insulator.

The drawbacks of Townsend's law are

- i) It is applicable for low pressure gases only
- ii) dielectric breakdown depends upon pressure & distance b/w electrodes but this theory does not support much.
- iii) As per this theory electron discharge is uniform & continuous but this is not practical

van's law:

this law states that at high pressure the breakdown voltage is function of pressure of gas (P) and distance between electrodes (d)

$$V = f(P, d)$$

for this law

$$P f_1 \left(\frac{E}{P} \right)$$

$$f_2 \left(\frac{E}{P} \right)$$

here $E = \frac{V}{d}$

$$\alpha = P f_1 \left(\frac{V}{Pd} \right), \quad V = f_2 \left(\frac{V}{Pd} \right)$$

$$I = I_0 e^{Pd f_1 \left(\frac{V}{Pd} \right)} \left(1 - f_2 \left(\frac{V}{Pd} \right) \right)$$

for the Paschen's law distance between the electrodes is given by

$$d = \frac{1}{P f_1 \left(\frac{V}{Pd} \right)} \ln \left(1 + \frac{1}{f_2 \left(\frac{V}{Pd} \right)} \right)$$

3

Insulation materials:

Insulation materials should with thermal, mechanical and electrical stress. Insulation is important factor to maintain uniform current through out the circuit. Some of the major components to be insulated are

- i) Transformers
- ii) power capacitors
- iii) power cables
- iv) circuit breakers
- v) Rotating machines

Bachupally, Kukatpally, Hyderabad - 500090

No. 213989

ROLL NO.: 15241A0211

CLASS & BRANCH IV Btech EEE

NAME G. Renu SUBJECT High Voltage Engineering

SIGNATURE OF THE INVIGILATOR [Signature] DATE: 28/9/18

SEMESTER I II

I II

MID TERM EXAMINATION

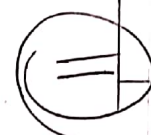

| | | | | | | |
|-------|---|---|---|---|---|-------|
| Q.NO. | 1 | 2 | 3 | 4 | 5 | TOTAL |
| | a | b | a | b | a | |
| MARKS | 2 | 4 | 5 | | | |

START WRITING FROM HERE

- 3) In any system insulation plays the major role. For a smooth working of a power system we need a strong and reliable insulation. There are many applications of Insulators.
- a) Rotating Machines: Motors and Generators
 Machines contain armature and field windings which if not insulated properly may misbehave
 ... always are used to protect machines

sends criteria for breakdown in gas
 along to Townsend, in any low pressure gas
 breakdown occurs with the increasing value
 current

for a gas which breakdown at I_0

$$I = \frac{I_0 e^{\alpha d}}{1 - \gamma(e^{\alpha d} + 1)}$$

- d is the distance at which we get the minimum value of this current
- Value of current at which breakdown occurs
- ~~Townsend's~~ primary coefficient
- ~~Townsend's~~ secondary coefficient
- distance between the plates

Let the maximum value be ∞

$$\therefore 1 - \gamma(e^{\alpha d} + 1) = 0$$

$$\gamma e^{\alpha d} + \gamma = 1$$

Value of γ is very small than $\gamma e^{\alpha d}$ therefore
 we can neglect it

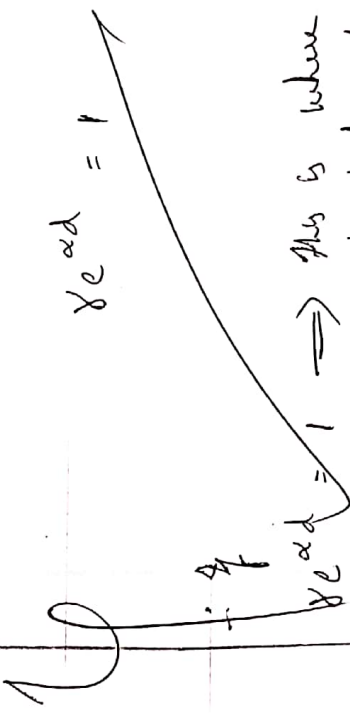

$\gamma e^{\alpha d} = 1 \Rightarrow$ This is where breakdown occurs
 and electron discharge starts to
 be continuous

$\gamma e^{\alpha d} > 1 \Rightarrow$ This is after the breakdown occurs
 and discharge is very high.

$\gamma e^{\alpha d} < 1 \Rightarrow$ This is before breakdown.
 Electron discharge is very low.

Gokaraju Rangaraju Institute of Engineering & Technology

(Autonomous)

Bachupally, Kukatapally, Hyderabad - 500090

o. 213923

ROLL NO.: 1 5 2 4 1 A 0 2 A C

SS & BRANCH IIth B.Tech. EEE - B

NAME Prithwan Anuresh . M SUBJECT HVE

SIGNATURE OF THE INVIGILATOR [Signature] DATE: 26/9/18

SEMESTER

| | |
|---|----|
| I | II |
|---|----|

| | |
|---|----|
| I | II |
|---|----|

MID TERM EXAMINATION

| Q.NO. | 1 | | 2 | | 3 | | 4 | | 5 | | TOTAL |
|-------|---|---|---|---|---|---|---|---|---|---|-------|
| | a | b | a | b | a | b | a | b | a | b | |
| MARKS | 2 | | 2 | | 2 | | 2 | | 2 | | |

START WRITING FROM HERE

What is meant by ionization. Explain the

break down procedure in gaseous dielectric.

The process of extracting an ion from the

molecule is known as ionisation -

Generally the process of extracting the electron from the molecule is known as ionisation.

In gaseous dielectrics the electron on the outer most orbital is removed by ionisation or by the gas dielectric.

Dielectric gas doesn't allow the flow of electrons.

Ex: Sulphur Hexa fluoride (SF_6).

Briefly explain the Paschen's criteria of breakdown in gases and explain the Paschen's law.

The Townsend's criteria gives the expression for spark under breakdown phenomenon.

↓
spark
atmosphere

Paschen's law gives the breakdown strength in terms of density of the gas and distance in between the electrodes.

3) Explain the applications of insulating materials and illustrate with examples.

There are several different types of insulating materials.

Some of which are rubber, silicon, wood

Insulating materials have vast uses in many different fields.



Academic Year: 2018-19

MID Exam - I
HIGH VOLTAGE ENGINEERING
Code: GR15A4147

Date: 26.09.2018(AN)
Duration: 30 min
Max Marks: 5

No: 1 5 2 4 1 A 0 2 1 1

ownsend's criteria gives the expression for voltage current Power Both B&C
ulator is always placed between _____ for breakdown procedure
lectrodes B) batteries C) capacitors D) equi potential sources
e avg distance between the collisions is known as
e path Mean free path C) collision path D) all the above
gan free path is very large for _____ pressure gaseous dielectrics (A)
w B) high C) medium D) Does not depend on pressure of gas
schen's Law defines the breakdown strength in terms of
oltage and current pressure of the gas and distance b/w Electrodes
ensity of the gas and distance b w Electrodes D) all the above

in the blanks:
Dielectric strength: The insulating property of a substance which fluid the flow through it is known as dielectric strength
Two examples for each solid, liquid and gaseous dielectrics:
Solid: Rubber, PVC Liquid: Anter oil, vegetable oil
Gas: SF6, vacuum
Multi-layer's are used as insulators in both Generators and Motors: True/False True
ermal energy will be changed in which type of collisions elastic
Most powerful gaseous dielectric SF6

G. Reddy
1524/A0211

EEE - A
A112

Academic Year: 2017-18

MID Exam - I
HIGH VOLTAGE ENGINEERING
Code: GR15A4147

Date: 26/10/2018(AN)
Duration: 30 min
Max Marks: 5

Roll No: 1 5 2 4 1 A 0 2 0 4

1. Cascaded voltage multiplier circuits require _____ supply and isolating transformers A)
A) single B) many C) two or three D) None A)
2. Tesla coil is used for generation of
A) High frequency AC voltages B) rectangular C) sinusoidal voltages D) impulse voltages B)
3. A trigetron gap is used with
A) transformer units B) impulse voltage generator C) impulse current generator D) all the above C)
4. Electrostatic voltmeters can measure _____ voltages
A) both AC & DC B) only AC C) only DC D) impulsive A)
5. Sphere gaps are used to measure _____ voltages
A) DC, AC peak and impulsive B) DC C) AC D) None

Fill in the blanks:

6. Define peak to peak ripple: It the difference between the voltages of the system at their maximum
7. Parallel resonant transformer test system is used when _____ system require pure sinusoidal waveform of same amplitude
8. Impulse current generator output wave form is critically damped: True/False False
9. CVT when tuned does not have phase angle error: True/False True
10. The equivalent circuit of a surge arrester may be represented as RC parallel circuit

MID Exam - 1
HIGH VOLTAGE ENGINEERING
Code: GR15A4147

Date: 26/10/2018(AN)
Duration: 30 min
Max Marks: 5

1 5 2 4 1 A 0 2 4 4

(A)

- ded voltage multiplier circuits require _____ supply and isolating transformers [A]
 B) many C) two or three D) None
- oil is used for generation of _____ [A]
 frequency AC voltages B) rectangular C) sinusoidal voltages D) impulse voltages
- iron gap is used with _____ [C]
 former units B) impulse voltage generator C) impulse current generator D) all the above
- static dielectric meters can measure _____ voltages [B]
 AC & DC B) only AC C) only DC D) impulsive
- gaps are used to measure _____ voltages [0]
 AC peak and impulsive B) DC C) AC D) None
- blanks:
 peak to peak ripple: _____
 resonant transformer test system is used when _____
- current generator output wave form is critically damped: True/False T
 en tuned does not have phase angle error: True/False F
 Invariant circuit of a surge arrester may be represented as _____



MID Exam - 1
HIGH VOLTAGE ENGINEERING
Code: GR15A4147

Date: 26/09/2018(AN)
Duration: 30 min
Max Marks: 5

Roll No: 1 5 2 4 1 A 0 2 1 4

(5)

- Academic Year: 2018-19
 Year: IV
 Semester: I
1. Townsend's criteria gives the expression for _____ under breakdown phenomenon [B]
 A) voltage B) current C) Power D) Both B&C
2. Insulator is always placed between _____ for breakdown procedure [A]
 A) Electrodes B) batteries C) capacitors D) equi potential sources
3. The avg distance between the collisions is known as [B]
 A) free path B) Mean free path C) collision path D) all the above
4. Mean free path is very large for _____ pressure gaseous dielectrics [A]
 A) low B) high C) medium D) Does not depend on pressure of gas
5. Paschen's Law defines the breakdown strength in terms of [B]
 A) voltage and current B) pressure of the gas and distance b/w Electrodes
 C) Density of the gas and distance b/w Electrodes D) all the above
- Fill In the blanks:
 6. Define Dielectric strength.
 It is the defined as the ability of medium of the resist the flow of current through it.
 7. Give two examples for each solid, liquid and gaseous dielectrics:
 Solid - wood, sulphur liquid - oil, liquid nitrogen
 Gaseous - SF6, air
8. MVA multipliers are used as insulators in both Generators and Motors: True/False True
9. Internal energy will be changed in which type of collisions: Inelastic collisions
10. Most powerful gaseous dielectric: SF6



Academic Year: 2018-19

Year: IV

Semester: I

MID Exam - I
HIGH VOLTAGE ENGINEERING
Code: GR15A4147

Date: 26/09/2018(AN)

Duration: 30 min

Max Marks: 5

Roll No: 2

Roll No: 1 5 2 4 1 A 0 2 A 0

Send's criteria gives the expression for _____ under breakdown phenomenon (b) ✓

A) current C) Power D) Both B&C

ator is always placed between _____ for breakdown procedure (c) X

A) batteries B) capacitors C) diodes D) equi potential sources (c) X

avg distance between the collisions is known as (c) X

A) Mean free path B) collision path C) collision path D) all the above

in free path is very large for _____ pressure gaseous dielectrics (b) [a] ✓

A) high B) medium C) low D) Does not depend on pressure of gas

Steen's Law defines the breakdown strength in terms of _____ (c) X

A) voltage and current B) pressure of the gas and distance b/w Electrodes

viscosity of the gas and distance b/w Electrodes C) all the above

the blanks:

Dielectric strength:

Amount of energy required to make the atoms most e^0 free X

Two examples for each solid, liquid and gaseous dielectrics:

solid: Silicon, Germanium, Rubber X
liquid: SF₆

Dielectric strength: _____

Dielectric strength: _____

Dielectric strength: _____

Dielectric strength: _____

Dielectric strength: _____

Dielectric strength: _____

Dielectric strength: _____

Dielectric strength: _____

Dielectric strength: _____

Dielectric strength: _____

Dielectric strength: _____

Dielectric strength: _____

Dielectric strength: _____

Dielectric strength: _____



Academic Year: 2017-18

Year: IV

Semester: I

MID Exam - I
HIGH VOLTAGE ENGINEERING
Code: GR15A4147

Date: 26/10/2018(AN)

Duration: 30 min

Max Marks: 5

Roll No: 15

Roll No: 1 5 2 4 1 A 0 2 A 0

1. Cascaded voltage multiplier circuits require _____ supply and isolating transformers (a)

A) single B) many C) two or three D) None

2. Tesla coil is used for generation of (a)

A) High frequency AC voltages B) rectangular C) sinusoidal voltages D) impulse voltages

3. A trigetron gap is used with (d)

A) transformer units B) impulse voltage generator C) impulse current generator D) all the above

4. Electrostatic voltmeters can measure _____ voltages (c)

A) both AC & DC B) only AC C) only DC D) impulsive

5. Sphere gaps are used to measure _____ voltages (d)

A) DC, AC peak and impulsive B) DC C) AC D) None

6. Define peak to peak ripple:

7. Parallel resonant transformer test system is used when AC supply

8. Impulse current generator output wave form is critically damped: True/False True

9. CVT when tuned does not have phase angle error: True/False True

10. The equivalent circuit of a surge arrester May be represented as _____

Applications of insulating Materials :-

Any insulating materials must withstand the thermal, mechanical & Electrical stresses. Insulation is important factor in maintaining the uniform current flow in the circuit. These are some basic Powersystem apparatus which uses the applications of insulating materials.

- Transformers
- Rotating Machines
- Circuit Breakers
- Power Capacitors
- Power Cables

Transformers :-

- AS Transformers are heavy equipments & are mostly placed in outdoor areas so there may be chance of getting frequent lightning strokes & surge voltages.
- so the insulation should be very strong thermally, mechanical & electrically to overcome those lightning effects & High voltages.

Various Design types of insulations in P/f's are

- (i) Turn to Turn Insulation [In this insulation is made turn to turn]
- (ii) coil to coil Insulation [" " " " " coil to coil]

- (iii) Low voltage coil to Earth insulation (insulation b/w LV coil & Earth)
- (iv) High voltage coil to Earth insulation
- (v) High voltage coil to low voltage coil insulation

Rotating Machines :-

For Generators : The insulating materials are used ^{in the} as form of multilayers.

Eg : NMN Multilayers → made up of Nomex & Poly Ester films

For Motors : Here also NMN multilayers

Press boards

High temperature Polymers are used

as insulators.

Circuit Breakers :- Ckt breaker is a device which breaks the ckt whenever fault occurs i.e. separates healthy section from the faulty part.

Eg : for insulating materials → synthetic resins / oils

→ ceramics

→ SF₆

→ Vacuum

→ Air

Power Capacitors : For power capacitors, materials used for insulation purpose are

→ Mineral oils

→ Synthetic oils

→ Vegetable oils

→ Castor oils

Power system cables :- insulators which are used in cables are

→ Vulcanized rubber

→ PVC [for low & medium voltages]

→ Poly Ethylene

→ Teflon [for high temperature operations & high voltages]

→ Compressed gas

Ionization : The process of producing ions & electrons from neutral atoms, is known as ionization process.

Breakdown procedure in gaseous dielectrics :-

"Ionization by collision", clearly explains the Breakdown procedure in gaseous dielectrics.

→ When a free moving electron collides with a gas particle, a new electron & +ve ions are produced. It is called as ionization by collision.

→ Consider two parallel plates, one is anode & another one is cathode. These are connected to electric field 'E'.

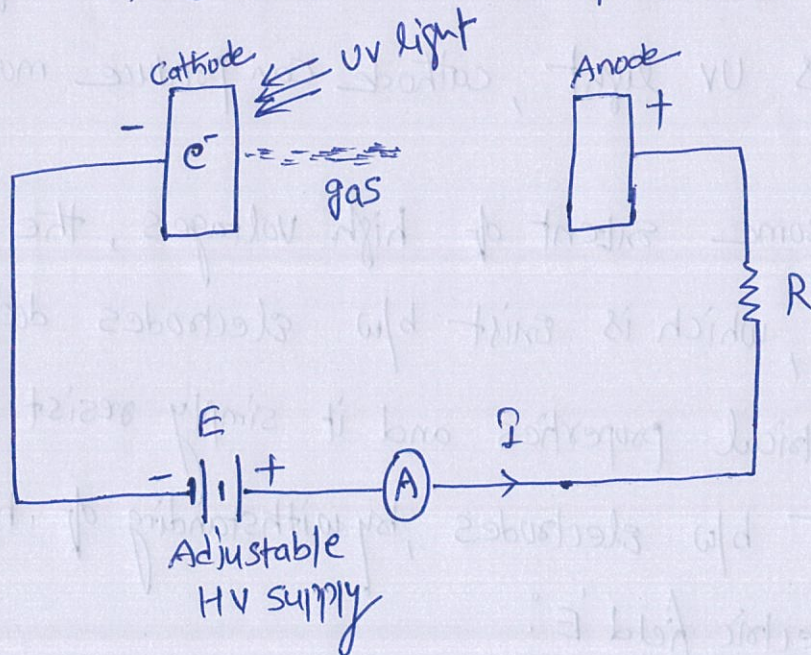

→ There exists a low pressure gas b/w the electrodes as a gaseous dielectric medium.

→ With the applying of Electric field, Electrons get active and travel towards anode from cathode with high speeds.

→ while travelling of an electrons from cathode to anode, collision takes place with the gas particles.

→ Because of this collision, Ionization process takes place, which results in formation of new electrons and +ve ions.

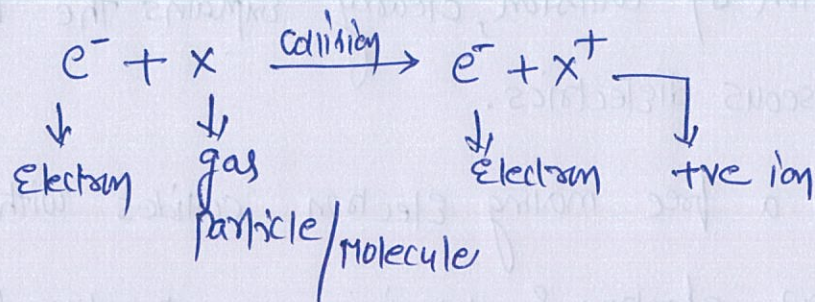

The above process is known as ionization by collision.

(Note) if we want more electrons from a cathode, need to arrange one external source like UV light, by exposure of this UV light, cathode can produce more no. of electrons.

→ upto some extent of high voltages, the gaseous dielectric, which is exist b/w electrodes does not loss its electrical properties and it simply resist the flow of current b/w electrodes, by withstanding of high voltages from electric field 'E'.

→ But at one instant of high voltages, gaseous dielectric/insulator losses its insulating property and works as a conductor by allowing the flow of currents b/w electrodes. This high voltage is known as Breakdown voltage. This phenomena is said to be Breakdown in gaseous dielectrics.

Townsend's criteria of Breakdown in gases:

Townsend's theory has given an empirical formula for total average current between electrodes during the breakdown phenomena. (The condition in which, dielectric (or) insulating material starts work as a conductor, so there exist a flow of current b/w electrodes in the form of spark)

The formula is,

$$I = \frac{I_0 e^{\alpha d}}{1 - \gamma [e^{\alpha d} - 1]}$$

where

α = Townsend's primary ionization coefficient

γ = Townsend's secondary ionization coefficient

d = distance b/w the electrodes

I_0 = initial current, (before breakdown process)

At some critical distance, i.e. when $d = d_s$,

the current b/w electrodes reaches its maximum value, under breakdown mechanism.

if it is assumed as $I \rightarrow \infty$ (infinity)

[that maximum value of current is assumed as infinite value at particular critical distance]

Therefore when $I \rightarrow \infty$

$$1 - \gamma(e^{\alpha d} - 1) = 0$$

$$\gamma(e^{\alpha d} - 1) = 1$$

$$\therefore I = \frac{I_0 e^{\alpha d}}{1 - \gamma(e^{\alpha d} - 1)}$$

$$\infty = \frac{I_0 e^{\alpha d}}{1 - \gamma(e^{\alpha d} - 1)}$$

It should be zero for $I \rightarrow \infty$

$$\gamma e^{\alpha d} - \gamma = 1$$

Here the exponential term is very large when compared to γ , so by neglecting γ



$$\gamma e^{\alpha d} = 1$$

This is the condition of Breakdown according to Townsend's theory.

From above, these are 3 conditions, proposed by Townsend's criteria.

(1) $\gamma e^{\alpha d} = 1$

\longrightarrow at this condition breakdown occurs but breakdown phenomena is in starting condition. (partially insulator starts behaving as a conductor)

(2) $\gamma e^{\alpha d} > 1$

\longrightarrow During this condition, emission of electrons increases sharply, i.e. flow of current increases, such that breakdown phenomena is in peak stage. (completely insulator works as a conductor)

(3) $\gamma e^{\alpha d} < 1$

\longrightarrow During this condition, there is no emission of electrons, hence no flow of current.

So breakdown phenomena stops (i.e. insulator comes back to its original position from conducting state)

But there are some drawbacks for this theory,

→ This theory is applicable only for low pressure gases.

→ In general breakdown voltage depends upon the gas pressure & distance b/w electrodes but Townsend

theory does not support this much.

→ According to this theory, electrical discharges are regular but practically it is not correct.

Paschen's law :-

Paschen's law states that at higher pressure, the breakdown strength of any dielectric material (insulator) is a function of the product of gas pressure (P) and electrode gap length (distance b/w electrodes) (d)

so it can be written as

$$V = f(Pd)$$

where V = Breakdown strength (V/cm)
(dielectric strength)

P = pressure of the gas

d = distance b/w electrodes

Townsend's primary & secondary ionization coefficients are defined as functions of $\left(\frac{E}{P}\right)$, as below

$$\alpha = P \left[f_1 \left(\frac{E}{P} \right) \right]$$

$$\gamma = f_2 \left(\frac{E}{P} \right)$$

where $E =$ Electric field intensity

substitute $E = \frac{V}{d}$

$$\therefore \alpha = P \left[f_1 \left(\frac{V}{Pd} \right) \right]$$

$$\gamma = f_2 \left(\frac{V}{Pd} \right)$$

we have the equation from Townsend's theory,

$$\gamma (e^{\alpha d} - 1) = 1$$

by substituting α & γ in above equation

$$f_2 \left(\frac{V}{Pd} \right) \left[e^{Pd f_1 \left(\frac{V}{Pd} \right)} - 1 \right] = 1$$

→ Paschen's law in terms of Townsend's coefficients

There is a Paschen's exponential curve, which gives the relation b/w V & Pd .

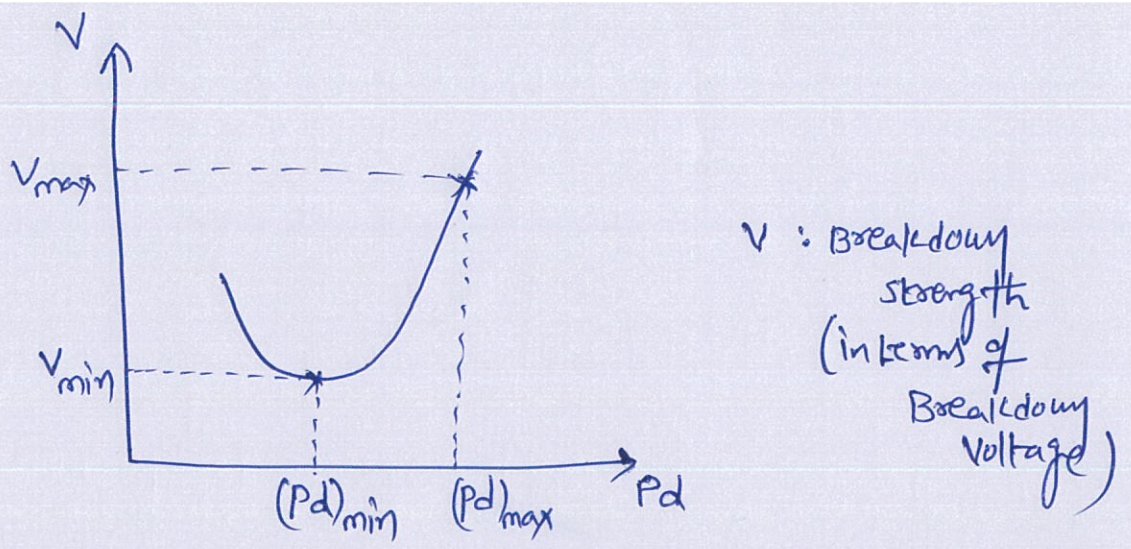

When the product of $P \& d$ is minimum, breakdown strength of dielectric material is minimum. When it is maximum, the dielectric strength of gaseous dielectric material is maximum.

→ There is an expression for distance b/w electrodes given by Paschen's law,

$$d = \frac{1}{\alpha} \left[\ln \left(1 + \frac{1}{\gamma} \right) \right]$$

By substituting α, γ in above eq

$$d = \frac{1}{P f_1 \left(\frac{V}{Pd} \right)} \left[\ln \left(1 + \frac{1}{f_2 \left(\frac{V}{Pd} \right)} \right) \right]$$

MODULE-I

Electrical materials constitute an extreme group of industrial materials that go specifically for manufacture of electrical machines, electrical apparatus, instruments, and other elements of electrical equipment and installations.

By the behaviour in an electric and magnetic field, or both, we ordinarily categorize all of these materials into major groups.

1. Dielectric
2. Conducting
3. Semiconducting
4. Magnetic materials

Reliability of product depend on quality of materials which are defined by the material characteristics

Electrical materials -> Thermal, Electrical, Atmospheric, Mechanical
Magnetic materials -> Magnetic characteristics

Mechanical characteristics -> Tensile strength
→ Compressive strength
→ Bending strength
→ Elasticity

Electrical characteristics -> Resistivity
→ Temperature coefficient of resistivity
→ Dielectric Constant
→ Electronic polarisation
→ Dielectric polarisation
→ $\tan\delta$ (loss tangent)
→ Breakdown strength

Atmospheric -> Viscosity
→ Tropical resistance
→ Acid number

Thermal -> Melting point
→ Softening point
→ Heat stability
→ Thermal Endurance

1. CONDUCTION AND BREAKDOWN IN GASES

The high-voltage power system, in general consists of a complex configuration of generators, long-distance transmission lines and localized distribution networks with above- and below-ground conductors for delivering energy to users. Associated with this are a wide range of high-voltage components whose successful operation depends on the correct choice of the electrical insulation for the particular application and voltage level. The condition of the insulating materials when new, and especially as they age, is a critical factor in determining the life of much equipment. The need for effective maintenance, including continuous insulation monitoring in many cases, is becoming an important requirement in the asset management of existing and planned power systems. As the voltages and powers to be transmitted increased over the past hundred years the basic dielectrics greatly improved following extensive research by industry and in specialized high voltage laboratories, where much of this work continues.

BACK GROUND MATERIAL

Recollect kinetic theory of gases (Developed by Maxwell)

$PV=nRT$ where numerically R is equal to $8.314 \text{ joules/}^\circ\text{Kmol}$.

The fundamental equation for the kinetic theory of gas is derived with the following assumed conditions:

- Gas consists of molecules of the same mass which are assumed spheres.
- Molecules are in continuous random motion.
- Collisions are elastic – simple mechanical.
- Mean distance between molecules is much greater than their diameter.
- Forces between molecules and the walls of the container are negligible.

1.1 Gases as Insulating Media

The most common dielectrics are gases. Many electrical apparatus use air as the insulating medium, while in a few cases other gases such as N_2 , CO_2 , CCl_2F_2 (freon) and SF_6 (hexafluoride) are used.

Gases consist of neutral molecules, and are, therefore, good insulators. Yet under certain conditions, a breakdown of the insulating property occurs, and current can pass through the gas. Several phenomena are associated with the electric discharge in gases; among them are spark, dark (Townsend) discharge, glow, corona, and arc.

In order to conduct electricity, two conditions are required. First, the normally neutral gas must create charges or accept them from external sources, or both. Second, an electric field should exist to produce the directional motion of the charges.

Various phenomena occur in gaseous dielectrics when a voltage is applied.

-When low voltage is applied, small current flow between the electrodes and the insulation retains its electrical properties.

-If the applied voltage is large, the current flowing through the insulation increases very sharply and an electrical breakdown occur. A strongly conducting spark formed during breakdown, practically produces a short circuit between the electrodes. The maximum voltage applied to the insulation at the moment of breakdown is called the breakdown voltage.

In order to understand the breakdown phenomenon in gases, the electrical properties of gases should be studied. The processes by which high currents are produced in gases is essential. The electrical discharges in gases are of two types;

- i) non-sustaining discharges
- ii) self-sustaining types.

The breakdown in a gas (spark breakdown) is the transition of a non-sustaining discharges into a self-sustaining discharge. The build up of high currents in a breakdown is due to the ionization in which electrons and ions are created from neutral atoms or molecules, and their migration to the anode and cathode respectively leads to high currents. Townsend theory and Streamer theory are the present two types of theories which explain the mechanism of breakdown under different conditions as pressure, temperature, electrode field configuration, nature of electrode surfaces and availability of initial conducting particles.

1.2 Ionization Process

The Townsend discharge is named after John Sealy Edward Townsend, (7 June 1868 – 16 February 1957) a mathematical physicist of Oxford University. He has discovered the fundamental ionization mechanism by his work between 1897 and 1901.

Consider a simple electrode arrangement as shown in the Fig 1.1, having two parallel plate electrodes (representing uniform field geometry) separated by a distance d and immersed in a gas at pressure p . A uniform electric field E is applied between two electrodes. Due to any external radiation (ultra violet illumination) free electrons are liberated at the cathode. When an electron, e is placed in an E , it will be accelerated with a force eE (coulomb force) towards the anode, and it gains an energy

$$u = eEx = \frac{1}{2}mv^2 \quad (\text{eqn. 1.1})$$

where x is the distance traveled by the electron from the cathode, m is the mass and v is the velocity of the electron.

This electron collides with the other gas molecules while it is traveling towards the anode. If the energy of the electron is sufficiently large (about 12.2 eV for N_2 or 15.5 eV for O_2), on collision it will cause a break-up of the atom or molecule into positive ion and

electron, so the new electrons and positive ions are created. Thus created electrons form a group or an avalanche and reach the anode. This is the electric current and if it is sufficiently large it results in the formation of a conducting path between the electrodes resulting in the breakdown of the gap.

Townsend conducted experiments on the growth of these currents which led to breakdown under d.c. voltage conditions, and he proposed a theory to explain the phenomenon.

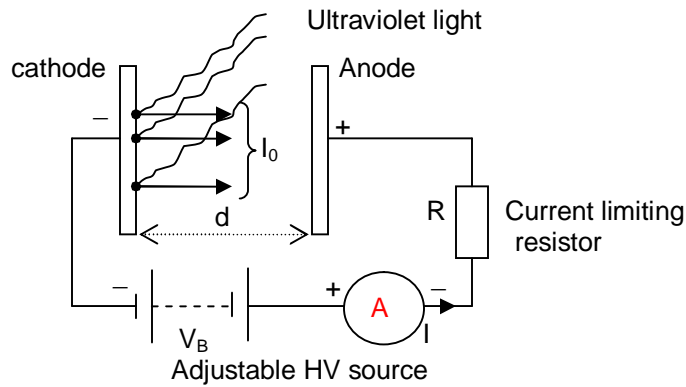

Fig. 1.1 Arrangement for study of a Townsend discharge

1.3 Townsend's Current Growth Equation

Assuming n_0 electrons are emitted from the cathode and when one electron collides with a neutral particle, a positive atom and electron formed. This is called an ionization collision.

Let α be the average number of ionizing collisions made by an electron per centimeter travel in the direction of the field where it depends on gas pressure p and E/p , and is called the **Townsend's first ionization coefficient or primary ionization coefficient**. At any distance x from the cathode (cathode is at $x=0$) when the number of electrons, n_x , travel a distance of dx they give rise to $(\alpha n_x dx)$ electrons. Then, the number of electrons reaching the anode at $x=d$, n_d will be $n_0 = n_x|_{x=0}$ (eqn. 1.2)

$$\frac{dn_x}{dx} = \alpha n_x \text{ or } n_x = n_0 e^{\alpha x} \quad (\text{eqn. 1.3})$$

and

$$n_d = n_0 e^{\alpha d} \text{ at } x=d. \quad (\text{eqn. 1.4})$$

The number of new electrons created, on the average, by each electron is

$$e^{\alpha d} - 1 = \frac{n_d - n_0}{n_0} \quad (\text{eqn. 1.5}).$$

Therefore the average current in the gap, which is equal to the number of electrons traveling per second will be

$$I = I_0 e^{\alpha d} \text{ where } I_0 \text{ is the initial current at the cathode.} \quad (\text{eqn. 1.6})$$

This current being dependent on I_0 does not represent self sustaining discharge.

1.4 Current Growth Equation in the Presence of Secondary Processes

When the initial set of electrons reaches the anode, the single avalanche process is completed. Since the amplification of electrons e^{ad} is occurring in the field, the probability of additional new electrons being liberated by other mechanisms increases, and created further avalanches and are called as secondary electrons. The other mechanisms resulting in secondary processes are

- i) The positive ions created in the gap due to ionization shall drift towards cathode and may have sufficient energy to cause liberation of electrons from the cathode(emission) when they impinge on it.(less efficient)
- ii) The excited atoms or molecules in avalanches may emit photons, and this will lead to the emission of electrons due to photo-emission.
- iii) the metastable particles (like mercury, and rare gases) may diffuse back causing electron emission.

Defining the Townsend's secondary ionization coefficient γ in the same way as α , then the net number of secondary electrons produced per incident positive ion, photon, excited particle or metastable particle and the total value of γ due to the three different processes is $\gamma = \gamma_1 + \gamma_2 + \gamma_3$ and is function of gas pressure p and E/p .

Following Townsend's procedure for current growth, let us assume

n_0' = number of secondary electrons produced due to secondary γ processes.

Let n_0'' = total number of electrons leaving the cathode.

$$\text{Then } n_0'' = n_0 + n_0' \quad (\text{eqn. 1.7})$$

the total number of electrons n reaching to the anode becomes,

$$n = n_0'' e^{ad} = (n_0 + n_0') e^{ad} \text{ and } n_0' = \gamma [n - (n_0 + n_0')]$$

$$\text{Eliminating } n_0', \quad n = \frac{n_0 e^{ad}}{1 - \gamma(e^{ad} - 1)} \text{ or } I = \frac{I_0 e^{ad}}{1 - \gamma(e^{ad} - 1)} \quad (\text{eqn. 1.8})$$

1.5 Townsend's Criterion for Breakdown

Eqn. 1.8 give the total average current in a gap before the occurrence of breakdown. The denominator in this Eqn.1.8 (2nd Term) is less than unity. So as α increases due to more gradient or d is increased, the denominator becomes smaller and current larger.

As the distance between the electrodes d is increased, the denominator of equation tend to zero and at some critical distance $d=d_s$

$$1 - \gamma(e^{ad} - 1) = 0 \quad (\text{eqn. 1.9})$$

For values of $d < d_s$, I is approximately equal to I_0 and if the external source for the supply of I_0 is removed, I becomes zero. If $d=d_s$, $I \Rightarrow \infty$ and the current will be limited only by the resistance of power supply and the external circuit.

This condition is called **Townsend's Breakdown Criterion** and can be written as $\gamma(e^{ad} - 1) = 1$.

Normally, $e^{\alpha d}$ is very large, and hence the above equation reduces to

$$\gamma e^{\alpha d} = 1 \quad (\text{eqn. 1.10})$$

For a given gap spacing and at a given pressure the value of voltage V which gives the values of α and γ satisfying the breakdown criterion is called the spark breakdown voltage V , and the corresponding distance d is called the sparking distance.

Townsend Mechanism explains the phenomena of breakdown only at low pressures, corresponding to $p \times d$ values of 1000 torr-cm and below.

1.5.1 Determination of Townsend's Coefficients α and γ

Townsend's coefficients are determined in an ionisation chamber which is first evacuated to a very high vacuum of the order of 10^{-4} and 10^{-6} torr before filling with the desired gas at a pressure of a few torr. The applied direct voltage is about 2 to 10 kV, and the electrode system consists of a plane high voltage electrode and a low voltage electrode surrounded by a guard electrode to maintain a uniform field. The low voltage electrode is earthed through an electrometer amplifier capable of measuring currents in the range 0.01 pA to 10nA. The cathode is irradiated using an ultra-violet lamp from the outside to produce the initiation electron. The voltage current characteristics are then obtained for different gap settings. At low voltage the current growth is not steady. Afterwards the steady Townsend process develops as shown in Fig. 1.2.

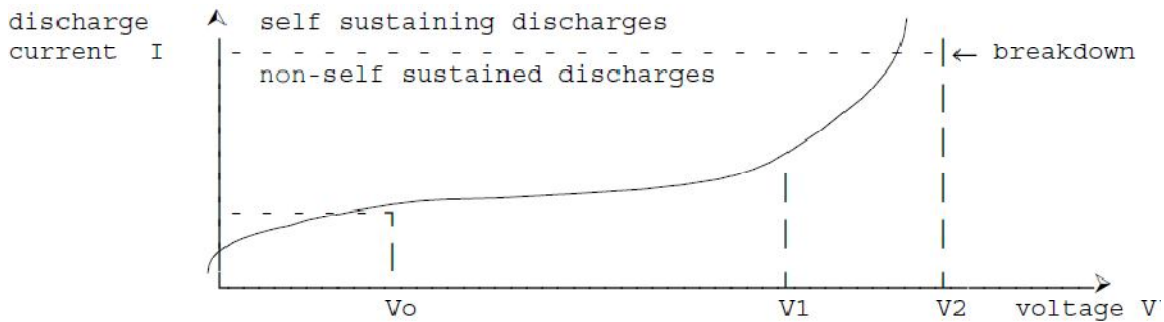

Fig.1.2 Growth of Current in gaseous dielectrics

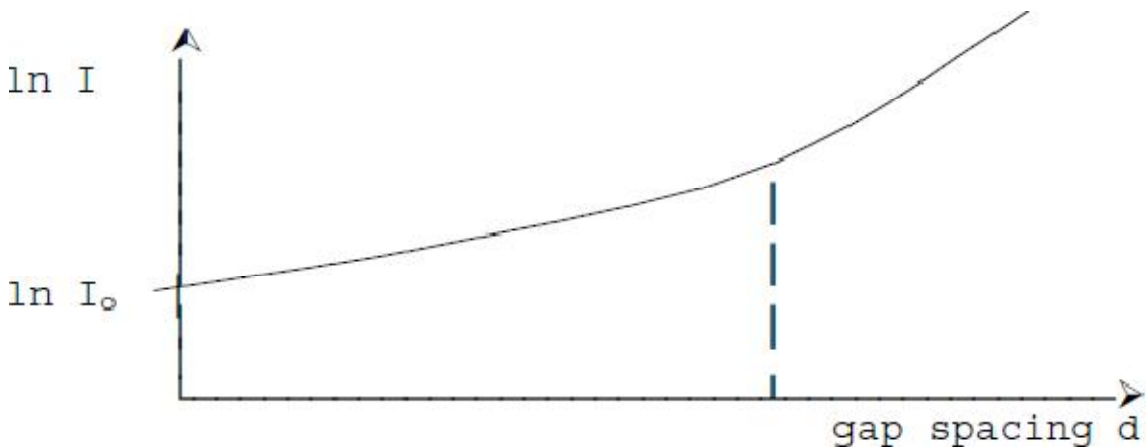
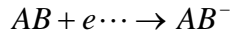

Fig.1.3 Plot of $\ln I$ vs. gap spacing d to determine the coefficients α and γ

1.6 Breakdown in Electronegative Gases

One process that gives high breakdown strength to a gas is the electron attachment in which free electrons get attached to a neutral atoms or molecules to form negative ions. Since negative ions like positive ions are too massive to produce ionization due to collisions, attachment represents an effective way of removing electrons which otherwise would have led to current growth and breakdown at low voltages. The gases in which attachment plays an active role are called electronegative gases. Two types of attachment are encountered in gases as;

a) Associative or Direct attachment: An electron directly attaches to form a negative ion.



b) Dissociative attachment: The gas molecules split into their constituent atoms and the electronegative atom forms a negative ion.

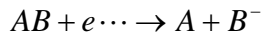

A simple gas for this type is the oxygen and others are sulphur hexafluoride(SF₆), Freon, carbon dioxide and fluorocarbons. In these gases, 'A' is usually sulphur or carbon atom and 'B' is oxygen atom or one of the halogen atoms or molecules.

The Townsend current growth equation is modified to include ionization and attachment with such gases. The current reaching the anode, can be written as,

$$I = I_0 \frac{\left[\frac{\alpha}{\alpha - \eta} e^{(\alpha - \eta)d} \right] - \left[\frac{\eta}{\alpha - \eta} \right]}{1 - \left[\gamma \frac{\alpha}{\alpha - \eta} e^{(\alpha - \eta)d} - 1 \right]} \quad \text{(eqn. 1.11)}$$

where η is the number of attaching collisions made by one electron drifting one centimeter in the direction of the field

The Townsend breakdown criterion for attaching gases can also be deduced from the denominator as,

$$1 - \left[\gamma \frac{\alpha}{\alpha - \eta} e^{(\alpha - \eta)d} - 1 \right] = 0. \text{ When } \alpha > \eta, \text{ breakdown is always possible irrespective of the values of } \alpha, \eta \text{ and } \gamma. \text{ If } \alpha < \eta \text{ then an asymptotic form is approached with increasing value of } d, \gamma \frac{\alpha}{\alpha - \eta} = 1 \text{ or } \alpha = \frac{\eta}{1 - \gamma}$$

Normally γ is very small ($\leq 10^{-4}$) and the above equation can be written $\alpha = \eta$. This condition puts a limit for E/p below which no breakdown is possible irrespective of the value of d , and the limit value is called the critical E/p . For SF₆ it is 117 Vcm⁻¹torr⁻¹, for CCl₂F₂ 121 Vcm⁻¹torr⁻¹ both at 20°C. η values can also experimentally determined.

1.7 Paschen's Law

The breakdown criterion $1 - \gamma(e^{\alpha d} - 1) = 0$ (1.9) where α and γ are functions of E/p , i.e.

$$\alpha/p = f_1\left(\frac{E}{p}\right) \text{ and } \gamma = f_2\left(\frac{E}{p}\right).$$

Also for uniform field gap $E = V/d$.

Substituting for E in the expressions α and γ and rewriting equation (1.9) we have

$$f_2\left(\frac{V}{pd}\right) \left[e^{pd f_1(V/pd)} - 1 \right] = 1.$$

This equation shows a relationship between V and pd , and implies that the breakdown voltage varies as the product pd varies. Knowing the nature of functions f_1 and f_2 we can write the equation $V = f(pd)$ known as Paschen's law and has been experimentally established for many gases. Paschen's law is a very important law in high voltage engineering.

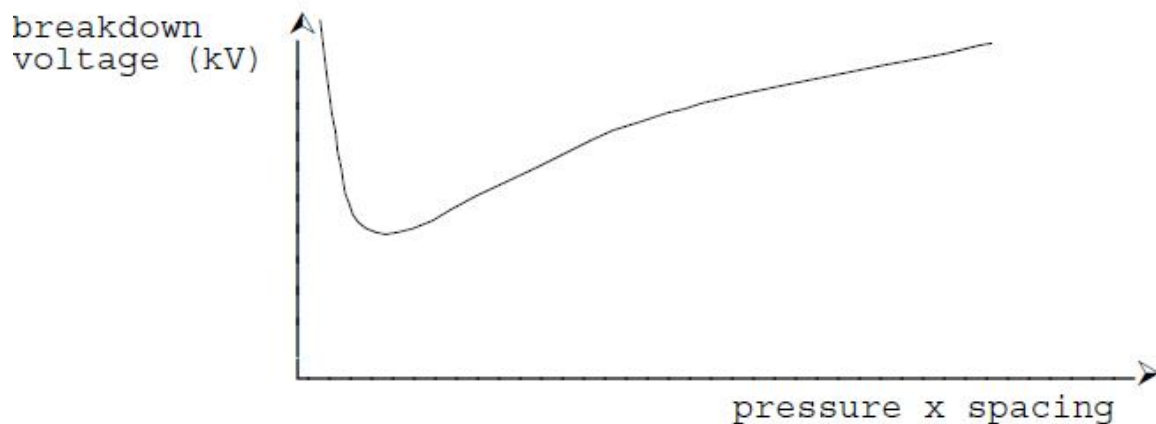

Fig.1.4 Variation of Breakdown voltage vs. pd

The relationship between V and pd is not linear and has a minimum value for any gas. The minimum breakdown voltages for various gases are as follow;

| Gas | $V_{s,min}(V)$ | pd at $V_{s,min}(\text{torr-cm})$ |
|--------|----------------|-------------------------------------|
| Air | 327 | 0.567 |
| H_2 | 273 | 1.15 |
| CO_2 | 420 | 0.51 |
| O_2 | 450 | 0.7 |
| SO_2 | 457 | 0.33 |
| Helium | 156 | 4.0 |

The existence of a minimum sparking potential in Paschen's curve may be explained as follows:

For values $pd > (pd)_{min}$ electrons crossing the gap make more frequent collisions with gas molecules than $(pd)_{min}$, but the energy gained between collisions is lower. Hence to maintain the desired ionization more voltage has to be applied.

For $pd < (pd)_{min}$ electron may cross the gap without even making a collision or making only less number of collisions. Hence more voltage has to be applied for breakdown to occur.

For the effect of temperature, the Paschen's law is generally stated as $V = f(Nd)$ where N is the density of the gas molecules. This is necessary since the pressure of the gas changes with temperature according to the gas law $pV = NRT$. The breakdown potential of air is expressed due to the experimental results as;

$$V = 24.22 \left[\frac{293pd}{760T} \right] + 6.08 \left[\frac{293pd}{760T} \right]^{1/2}$$

At 760 torr and 293°K

$$E = V/d = 24.22 + \left[\frac{6.08}{\sqrt{d}} \right] kV/cm. \text{ This equation yields a limiting value for } E \text{ of } 24 kV/cm$$

for long gaps and a value of $30 kV/cm$ for $\left[\frac{293pd}{760T} \right] = 1$, which means a pressure of 760 torr at 20°C with 1 cm gap. This is the breakdown strength of air at room temperature and at atmospheric pressure.

1.8 Time Lags for Breakdown

Theoretically the mechanism of spark breakdown is considered as a function of ionization processes under uniform field conditions. In practical engineering designs, the breakdown due to rapidly changing voltages or impulse voltages is of great importance. Actually there is a time difference between the application of a voltage sufficient to cause breakdown and the occurrence of breakdown itself. This time difference is called as the time lag.

In considering the time lag observed between the application of a voltage sufficient to cause breakdown and the actual breakdown the two basic processes of concern are the appearance of avalanche initiating electrons and the temporal growth of current after the criterion for static breakdown is satisfied.

In the case of slowly varying fields, there is usually no difficulty in finding an initiatory electron from natural sources (ex. cosmic rays, detachment of gaseous ions etc). However, for impulses of short duration (around 1 microsecond), depending on the gap volume, natural sources may not be sufficient to provide an initiating electron while the voltage is applied, and in the absence of any other source, breakdown will not occur.

The time t_s which elapses between the application of a voltage greater than or equal to the static breakdown voltage (V_s) to the spark gap and the appearance of a suitably placed initiatory electron is called the statistical time lag of the gap, the appearance being usually statistically distributed.

After such an electron appears, the time t_f required by the ionisation processes to generate a current of a magnitude which may be used to specify breakdown of the gap is known as the formative time lag. The sum $t_f + t_s = t$ is the total time lag, and is shown in the diagram. The ratio V/V_s , which is greater than unity, is called the impulse ratio, and clearly depends on $t_s + t_f$ and the rate of growth of the applied voltage.

(i) Statistical Time lag t_s

The statistical time lag is the average time required for an electron to appear in the gap in order that breakdown may be initiated.

If β = rate at which electrons are produced in the gap by external irradiation

P_1 = probability of an electron appearing in a region of the gap where it can lead to a spark

P_2 = probability that such an electron appearing in the gap will lead to a spark
then, the average time lag

$$t_s = 1/(\beta P_1 P_2)$$

If the level of irradiation is increased, β increases and therefore t_s decreases. Also, with clean cathodes of higher work function β will be smaller for a given level of illumination producing longer time lags.

The type of irradiation used will be an important factor controlling P_1 , the probability of an electron appearing in a favourable position to produce breakdown. The most favourable position is, of course near the cathode.

(ii) Formative time lag (t_f)

After the statistical time lag, it can be assumed that the initiatory electron is available which will

eventually lead to breakdown. The additional time lag required for the breakdown process to form is the formative time lag. An uninterrupted series of avalanches is necessary to produce the requisite gap current (μA) which leads to breakdown, and the time rate of development of ionisation will depend on the particular secondary process operative. The value of the formative time lag will depend on the various secondary ionisation processes. Here again, an increase of the voltage above the static breakdown voltage will cause a decrease of the formative time lag t_f .

The Townsend criterion for breakdown is satisfied only if at least one electron is present in the gap between the electrodes as in the case of applied d.c. or slowly varying (50 Hz a.c.) voltages. With rapidly varying voltages of short duration ($\approx 10^{-6}\text{s}$), the initiatory electron may not be present in the gap that the breakdown can not occur.

(iii) Time lag characteristics

The time lag characteristic is the variation of the breakdown voltage with time of breakdown, and can be defined for a particular waveshape. The time lag characteristic based on the impulse waveform is shown in Fig.1.5.

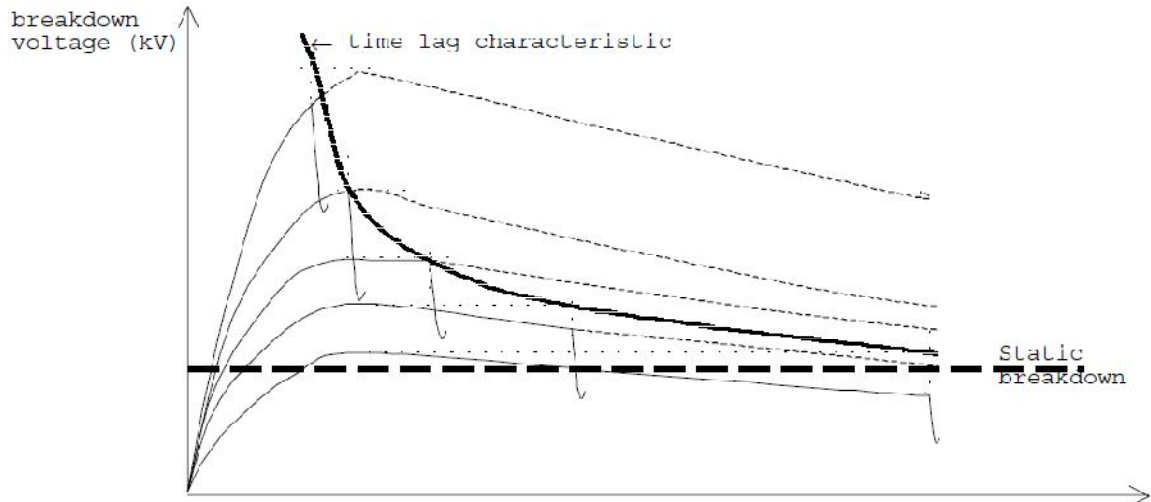

Fig.1.5 Time lag characteristic based on impulse waveform

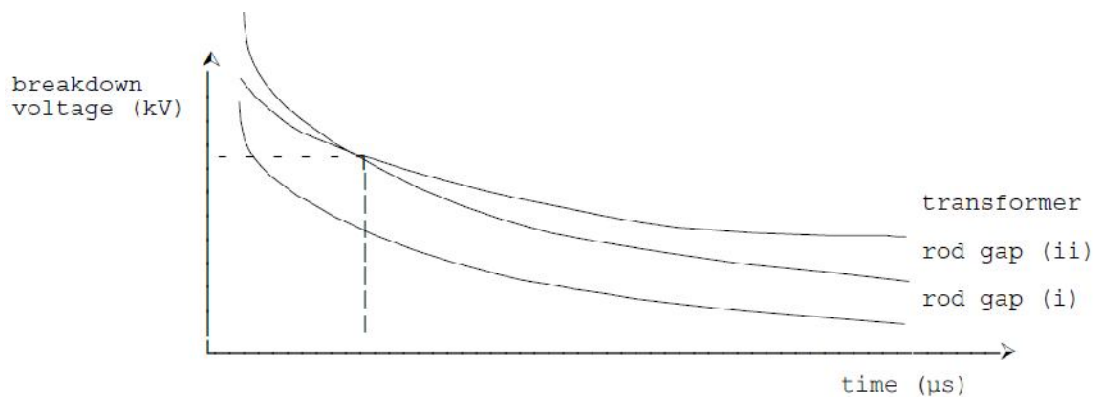

Fig.1.6 Voltage Time characteristics

The time lag characteristic is important in designing insulation. If a rod gap is to provide secondary protection to a transformer, then the breakdown voltage characteristic of the rod gap must be less than that of the transformer at all times (gap i) to protect it from dangerous surge voltages. This will ensure that the gap will always flashover before the protected apparatus. This is shown in figure 1.6.

However, with such a rod gap, the gap setting will be low, as the sharpness of the two characteristics are different. Thus it is likely that there would be frequent interruptions, even due to the smallest overvoltages which would in fact cause no harm to the system. Thus it is usual to have the rod gap characteristic slightly higher (gap ii) resulting in the intersection of the characteristics as shown. In such a case, protection will be offered only in the region where the rod gap characteristic is lower than that of the transformer. This crossing point is found from experience for a value of voltage which is highly unlikely to occur. The other alternative is of course to increase the transformer characteristic which would increase the cost of the transformer a great deal. [This decision is something like saying, it is better and cheaper to replace 1 transformer a year due to this decision than have to double the cost of each of 100 such transformers in the system.]

1.9. Limitations of Townsend Theory

- (i) Fails to explain the formative time lag of breakdown
- (ii) Fails to explain the effect of space charge
- (iii) Fails to explain the discharge under high PD

1.10 Streamer Theory of Breakdown in Gases

According to the Townsend theory;

- firstly, current growth occurs as a result of ionization process only. But in practice, breakdown voltages were found to depend on the gas pressure and the geometry of the gap;
- secondly, the mechanism predicts time lags of order of 10^{-5} s, but practically it was observed to occur at a very short time of 10^{-8} s.
- Also the Townsend mechanism predicts a very diffused form of discharge, that actually discharges were found to be filamentary and irregular.

Townsend mechanism failed to explain all these observed phenomena and as a result The Streamer theory was proposed.

The theory predicts the development of a spark discharge directly from a single avalanche in which the space charge develop by the avalanche itself is said to transform

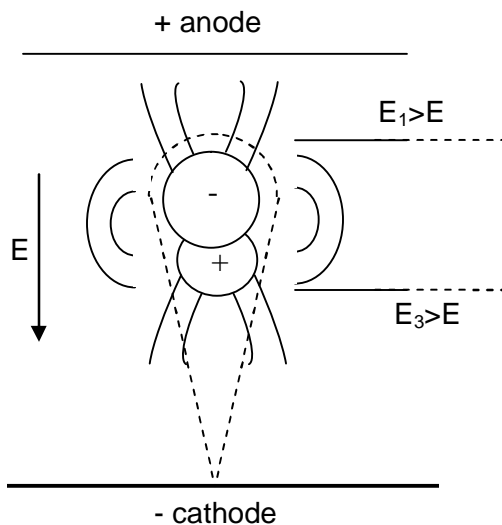

Fig.1.7 Effect of space charge produced by an avalanche on the applied electric field

the avalanche into a plasma steamer. In the Fig 1.7, a single electron starting at the cathode by ionization builds up an avalanche that crosses the gap. The electrons in the avalanche move very fast compared with the positive ions. By the time the electrons reach the anode the positive ions are in their original positions and form a positive space charge at the anode. This enhances the field, and the secondary avalanches are formed from a few electrons produced due to the photo-ionization in the space charge region. This occurs first near the anode where the space charge is maximum and a further increase in the space charge. This process is

very fast and the positive space charge extends to the cathode very rapidly resulting in the formation of a streamer. Comparatively narrow luminous tracks occurring at breakdown at pressures are called streamers. As soon as the streamer tip approaches to the cathode, a cathode spot is formed and a stream of electrons rush from the cathode to neutralize the

positive space charge in the streamer; the result is a spark and the spark breakdown has occurred.

A simple quantitative criterion to estimate the electric field E_r which is produced by the space charge, at the radius r and that transforms an avalanche into streamer is given by

$$E_r = 5.27 \times 10^{-7} \frac{\alpha e^{\alpha x}}{\sqrt{x/p}} \frac{V}{cm}$$

where α is the Townsend's first ionization coefficient, p is the gas pressure in torr and x is the distance to which the streamer has extended in the gap. When $E_r = E$ and $x = d$ the equation above simplifies into;

$\alpha d + \ln \alpha/p = 14.5 + \ln E/p + 0.5 \ln d/p$. This equation is solved between α/p and E/p at which a given p and d satisfy the equation. The breakdown voltage is given by the corresponding product Ed .

It is generally assumed that for pd values below 1000 torr-cm and gas pressures varying from 0.01 to 300 torr, The Townsend mechanism operates, while at higher pressures and pd values the streamer mechanism plays the dominant role in explaining the breakdown phenomena. However controversies still exist in these statements.

1.11 Breakdown in non-uniform field and Corona Discharges

In a uniform electric field, a gradual increase in voltage across a gap produces a breakdown of the gap in the form of a spark without any preliminary discharges. On the other hand, if the field is non-uniform, an increase in voltage will first cause a localised discharge in the gas to appear at points with the highest electric field intensity, namely at sharp points or where the electrodes are curved or on transmission line conductors. This form of discharge is called a corona discharge and can be observed as a bluish luminance. This phenomena is always accompanied by a hissing noise, and the air surrounding the corona region becomes converted to ozone. Corona is responsible for considerable power loss in transmission lines and also gives rise to radio interference. This also leads to deterioration of insulation by the combined action of the discharge ion bombarding the surface and the action of chemical compounds that are formed by the corona discharge.

In non-uniform fields, e.g. in point-plane, sphere-plane gaps or coaxial cylinders, the field strength and hence the effective ionization coefficient α vary across the gap. The electron multiplication is governed by the integral of α over the path $\int \alpha dx$.

The electrode configuration has great influence on the characteristics of the corona discharge. The typical configurations include point-to-plane or point-to-point, wire-to-wire, wire-to-plane or wire-to-cylinder, etc. Among them, the point-to-plane (or needle-to-plate) is the most typical and popular configuration. The corona discharge with the point-to-plane configuration has been investigated widely in air under various conditions. Investigation with point-plane gaps in air have shown that when point is positive, the corona current increases steadily with voltage. At sufficiently high voltage, current amplification increases rapidly with voltage upto a current of about 10^{-7} A, after which

the current becomes pulsed with repetition frequency of about 1 kHz composed of small bursts. This form of corona is known as *burst corona*.

The average current then increases steadily with applied voltage, leading to breakdown. With point-plane gap in air when negative polarity voltage is applied to the point and the voltage exceeds the onset value, the current flows in vary regular pulses known as *Trichel pulses*. The onset voltage is independent of the gap length and is numerically equal to the onset of streamers under positive voltage for the same arrangement. The pulse frequency increases with voltage and is a function of the radius of the cathode, the gap length and the pressure. A decrease in pressure decreases the frequency of the pulses. It should be noted that the breakdown voltage with negative polarity is higher than with positive polarity except at low pressure. Therefore, under alternating power frequency voltage the breakdown of non-uniform field gap invariably takes place during the positive half cycle of the voltage wave. Table 1 gives out the measured onset voltage V_C , the inception voltage of spark V_{spark} and the corresponding transition current I_{spark}

Table 1. The breakdown voltage and current in different gases and voltage polarity.

| | Ar | | He | | Air | | N ₂ | | O ₂ | |
|-------------------------------|------|------|------|-------|------|-------|----------------|-------|----------------|------|
| | + | - | + | - | + | - | + | - | + | - |
| V_C (kV) | 1.91 | 1.23 | 2.37 | 1.02 | 3.10 | 2.05 | 2.94 | 1.68 | 3.08 | 2.50 |
| V_{spark} (kV) | 3.24 | 2.15 | 5.07 | 2.24 | 5.42 | 5.08 | 5.10 | 4.32 | 5.82 | 6.69 |
| I_{spark} (μ A) | 6.00 | 32.0 | 50.0 | 101.0 | 20.0 | 145.0 | 15.0 | 365.0 | 33.0 | 94.0 |

The results show a significant polarity-effect. In all gases the onset voltage of positive corona is much higher than the negative corona. The breakdown Voltage of positive corona to spark is also higher than the negative except in O₂ that the result is inversed. The current of the negative corona is much larger than the positive in all gases. The current-voltage dependence of negative or positive corona shows the Townsend's relation. The negative corona has a large luminous area than the positive in all gases and shows a stable bell-shaped glow before spark, except in case of O₂ in which the negative corona exists near the tip of the cathode. The positive corona in all gases occurs only in a small region around the anode needle. The electronegative oxygen is suggested to play an important role in the characteristics of negative corona discharge.

The formation of corona causes the current waveform in the line, and hence the voltage drop to be non-sinusoidal. It also causes a loss of power. There is always some electrons present in the atmosphere due to cosmic radiation etc. When the line voltage is increased, the velocity of the electrons in the vicinity of the line increases, and the electrons acquire sufficient velocity to cause ionization.

To prevent the formation of corona, the working voltage under fair weather conditions should be kept at least 10% less than the disruptive critical voltage. Corona formation may be reduced by increasing the effective radius. Thus steel cored aluminium has the advantage over hard drawn copper conductors on account of the larger diameter, other conditions remaining the same. The effective conductor diameter can also be increased by the use of bundle conductors. Corona acts as a safety valve for lightning surges, by

causing a short circuit. The advantage of corona in this instance is that it reduces transients by reducing the effective magnitude of the surge by partially dissipating its energy due to corona.

The effect of corona on radio reception is a matter of some importance. The Corona frequency lies between 20 Hz and 20 kHz. The current flowing into a corona discharge contains high-frequency components. These cause interference in the immediate vicinity of the line. As the voltage is gradually increased, the disturbing field makes its appearance long before corona loss becomes appreciable. The field has its maximum value under the line and attenuates rapidly with distance. The interference falls to about a tenth at 50 m from the axis of the line

1.12 Post-Breakdown Phenomena and Applications

Post-Breakdown phenomenon (after actual breakdown) is of technical importance which occurs after the actual breakdown has taken place. Glow and arc discharges are the post-breakdown phenomena and there are many devices that operate over these regions. In a Townsend discharge (see Fig 1.8) the current increases gradually as a function of the applied voltage from point A. Further to this point B only the current increases and the discharge

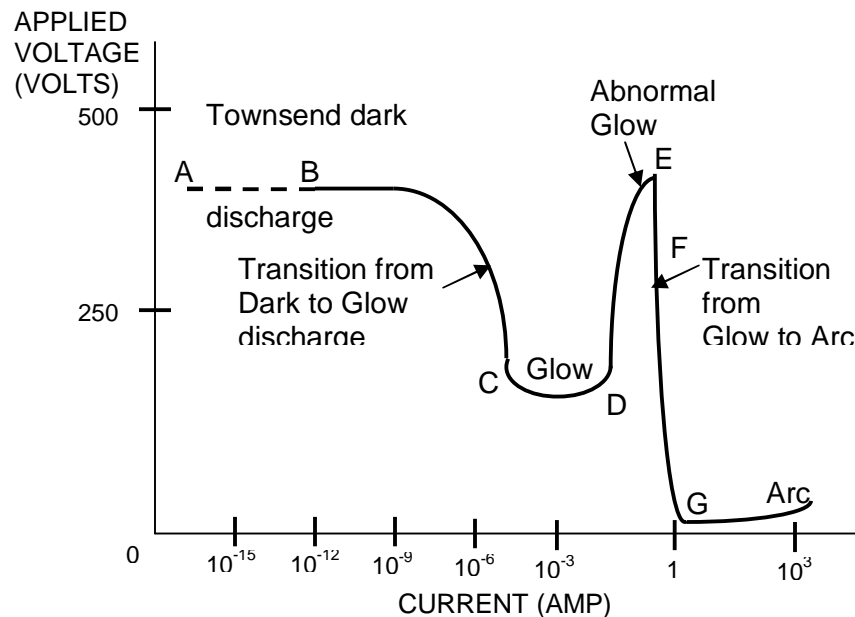

Fig.1.8 DC. voltage current characteristic at an electrical discharge with electrodes having no sharp points or edges

changes from the Townsend type to Glow type (BC). Further increase in current results in a very small reduction in voltage across the gap (CD) corresponding to the normal glow region. The gap voltage again increases (DE), when the current increases more, but eventually leads to a considerable drop to the applied voltage. This is the region of the Arc discharge (EG). The phenomena occurring in the region CG are the post-breakdown phenomena consisting of glow discharge CE and the arc discharge EG.

Atmospheric pressure air plasmas have potential applications in biomedical and surface treatment, chemical and biological decontamination, aerodynamic flow control, and combustion. Many of these applications require diffuse non-thermal i.e., glow discharges to meet requirements of large volume, low power, high chemical reactivity, and low gas temperature. At atmospheric pressure, glow discharges in air easily transition into spark discharges that significantly heat the gas, which is problematic for applications sensitive to temperature.

1.12.1 Glow Discharge(low-current, high-voltage discharge.)

A glow discharge is characterized by a diffused luminous glow. The color of the glow discharge depends on the cathode materials and the gas used. The glow discharge covers the cathode partly and the space between the cathode and the anode will have intermediate dark and bright regions. In a glow discharge the voltage drop between the electrodes is substantially constant, ranging from 75 to 300 V over a current range of 1 mA to 100 mA depending on the type of the gas. The properties of the glow discharge are used in many practical applications, such as, voltage regulation (VR) tubes, for rectification and as an amplifier. Corona is the name given to glow discharges at high pressure near points of high fields, usually caused by a small radius of curvature. Points are an obvious place for corona, and this is their intention in lightning rods. High tension conductors are another good place, but here it is very undesirable.

1.12.2 Arc Discharge(a high-current, low-voltage discharge)

If the current in the gap is increased to about 1 A or more, the voltage across the gap suddenly reduces to a few volts (20-50 V). The discharge becomes very luminous and noisy (region EG). The current density over the cathode region increases to very high values of 10^3 to $10^7 A/cm^2$. Arcing is associated with high temperature, ranging from 1000°C to several thousands degrees celcius. The discharge contain very high density of electrons and positive ions, and called as arc plasma. The study of arcs is important in circuit breakers and other switch contacts. It is convenient high temperature high intensity light source. It is used for welding and cutting of metals. It is the light source in lamps such as carbon arc lamp. High temperature plasmas are used for generation of electricity through magneto-hydro dynamic or nuclear fusion processes.

It was Humphrey Davy who investigated the basic spark gap and the nature of the arc between the conductors.

1.13 Write a brief note on CORONA

If the field is uniform , then an increase in voltage(A.C.) directly leads to breakdown without any preliminary discharge.

However in non-uniform geometry , the increase in a.c. voltage will cause a luminous discharge with the production of hissing noise at points with highest electric field intensity.

This form of discharge is termed as Corona discharge and is accompanied by the formation of ozone, as is indicated by the characteristic order of this gas.

If the voltage is d.c., then the appearance will be different. The positive wire will be having a uniform glow and negative wire has a more patchy glow often accompanied by streamers.

An important point in connection with corona that it is accompanied by a loss of power and this means that there is a flow of current to the wire. The current waveform is nonsinusoidal and the non-sinusoidal drop of volts caused by it may be more important than loss of power. It gives rise to radio interference.

The loss of power during corona discharge leads to deterioration of insulation due to combined action of the bombardment of ions and of the chemical compounds formed during discharges.

1.13.1 Practical Importance of Corona:

1.) Under normal conditions the loss of power due to corona is of no good importance, and consequently corona calculations do not enter directly into transmission line design. The basis of such design is entirely financially the most economical line being the most acceptable.

2.) The nonsinusoidal coronal current causes a nonsinusoidal drop of volts and these may cause some interference with neighboring communication (Carrardig TV) circuits due to electromagnetic and electrostatic induction. The current contains large third harmonic.

3.) Average corona loss on several lines from 345 KV to 750 KV gave 1 to 20 KW/Km in fair weather the higher values referring to higher voltages. In foul-weather the losses can go upto 300 KW/Km.

A reasonable estimate of the yearly average loss for 400 Km line is 2 KW/Km to 10 KW/Km and 20-40 KW/Km for 800 Km lines and it is 10% of I^2R loss.

None the less, during rainy months, the generating station has to supply heavy corona loss.

When a line is energized and no corona is present, the current is a pure sine wave and capacitive. It leads the voltage by 90° as shown in Fig(a). With corona it calls, for a loss component and a typical waveform of the total current is as shown in Fig(b). When the two components are separated, the resulting inphase component has a waveform which is not purely sinusoidal (Fig.(c)). It is still a current at power frequency, but only the fundamental component of this distorted current can result in power loss.

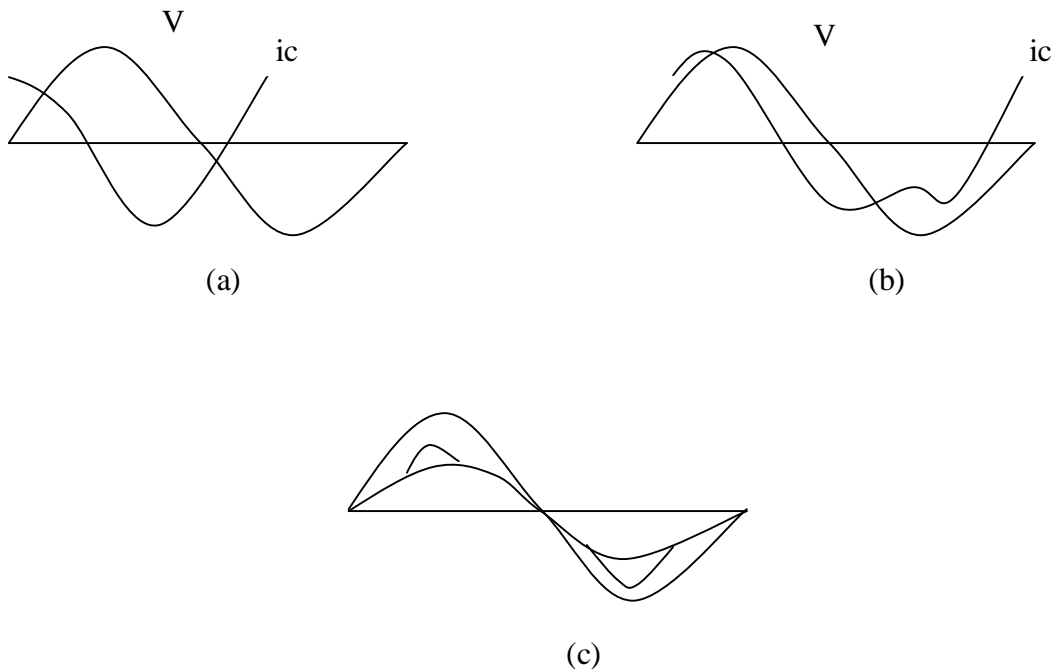

4.)An advantage of corona is that it reduces transients , since charges induced on the line by lightning or other causes will be partially dissipated as a corona loss . In this way it acts as a safety value , and in one or two cases , lines have been purposely designed to have an operating voltage near to critical voltage in order to do away with the necessity for, and expense of lightning arrestor gear. An objection to this scheme is that the critical voltage is not fixed for a given line , but may vary considerably with changes in weather.

5.)Audible noise: generation and characteristics.

When corona is present on the conductors EHV lines generate audible noise which is especially high during foul weather . The noise is in broad band , which extends from a very low frequency to about 20 KHz. Corona discharges generate positive and negative ions which are alternatively attracted and repelled by the periodic reversal of polarity of the ac excitation . Their movement gives rise to sound pressure waves at frequencies of twice the power frequency and its multiples in addition to the broadband spectrum which is the result of random motions of the ions as shown in Fig. below. The noise has a pure tone superimposed on the broad band noise. Due to difference in ionic motion between ac and dc excitations, dc lines extend only a broad band noise and it is nearly same for fair and foul weather conditions. Since AN (audible noise) is man-made , measured in the same manner as other types of man-made noise such as aircraft noise, transformer hum etc.

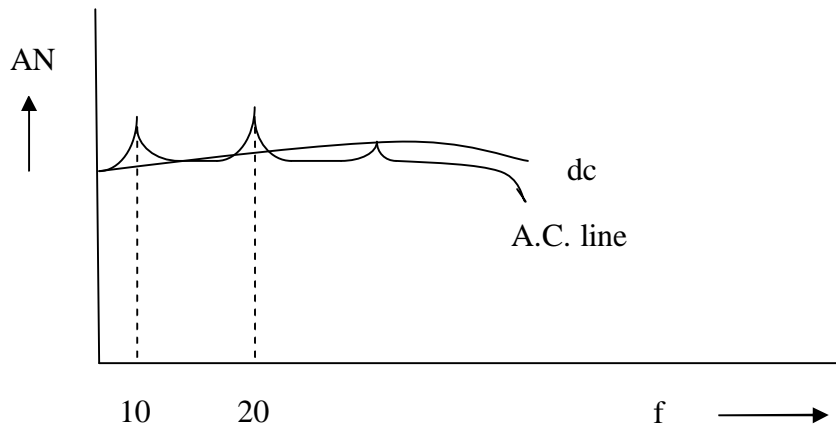

Fig.1.9 Audible noise spectra from ac and dc transmission lines

Audible noise can become a serious problem from a “psycho-acoustics” point of view, leading to insanity due to loss of sleep at night to inhabitants residing close to an hlv line. This problem came into focus in the 1960s with the energisation of 500kV lines in the USA. Regulation bodies have not as yet fixed limits to AN from power transmission lines since such regulations do not exist for other manmade sources of noise. The problem is left as a social one which has to be settled by public opinion.

The audible noise generated by a line is a function of the following factors:

1. The surface voltage gradient on conductor.
2. The number of sub conductors in the bundle.
3. Conductor diameter.
4. Atmospheric conditions.
5. The lateral distance(aerial distance) from the line conductors to the point where noise is to be evaluated.

The AN limits are:

- No complaints: less than 52.5dB
- Few complaints: 52.5 to 59 dB
- Many complaints: greater than 59dB

Radio interference:

There are in general two types of corona discharge from transmission line conductors

1. Pulse less or glow corona
2. Pulse type or streamer corona.

Both give rise to energy loss, but only the pulse type of ma gives interference to radio broadcast in the range of 5MHz to 1.6MHz. Besides thin, sparked

discharges from broken insulators and loose guy wires interfere with TV reception in the 80-200MHz range. Corona on conductors also causes interference to carrier communication and signalling in the frequency range 30kHz to 500kHz.

Mechanism of generation of pulse type corona:

In most gas discharge phenomenon, under high impressed electric fields, free electrons and charged particles(ions) are created in space which contain very few initial electrons. We can expect therefore a build up of resulting current in the conductor, from a zero value to a maximum or peak. Once the peak value is reached there is a fall in current because of lowering of electric field due to relatively heavy immobile space charge cloud which lowers the velocity of ions. We can therefore expect pulses to be generated with short rest times and relatively longer fall times.

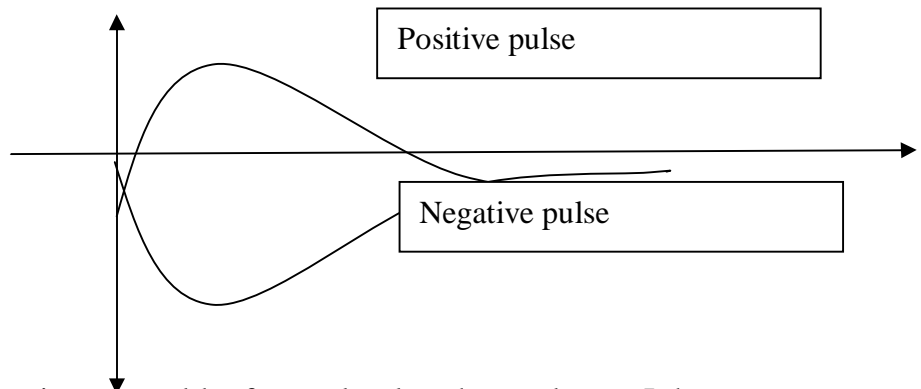

The repetition rate of pulses is governed by factors local to the conductor. It has been observed that only one pulse usually occurs during a positive half cycle in fair weather and could increase to 10 in rain if the conductor is +ve.

The situation when the conductor is negative is reverse. The electron avalanche moves away from conductor. Heavy positive ions move in the direction of high field. The lighter electrons move rapidly away from the conductor and the electrical field near the conductor regains its original value for the next pulse generation quicker than the positive case. Therefore negative pulses are smaller in amplitude, have much smaller rise and fall times but much higher repetition rates than positive pulses. The negative pulses are called Trichel pulses. Typical average values of pulse properties:

| Type | Time to crest (ns) | Time to 50% on tail(ns) | Peak value of current (in mA) | Repetition rate pulses per second | |
|----------|--------------------|-------------------------|-------------------------------|-----------------------------------|-------|
| | | | | AC | DC |
| Positive | 50 | 200 | 100 | 50 | 1000 |
| Negative | 20 | 50 | 10 | 100*p.f. | 10000 |

Pulses are larger as the diameter of conductor increases because the reduction in electric field strength as one moves away from the conductor is not as steep as for a small conductor so that conditions for longer pulse duration are more favourable.

RI level is governed by amplitude, wave shape and repetition rate of pulses.

1.14 Practical considerations in using gases for insulation purposes

The gases find wide application in power system to provide insulation to various electrical equipments and substations. The gases are also used in circuit breakers for arc interruption besides providing insulation between breaker contacts and from contact to the enclosure used for contacts. The various gases used are (i) air(widely used and cheapest) (ii) oxygen (iii) hydrogen(better arc quenching) (iv) nitrogen (v) CO₂ and (vi) electronegative gases like sulphur hexafluoride,(SF₆) (outstanding arc quenching and dielectric strength) or arcton(or Chlorodifluoromethane (HCFC 22)) etc.

For high voltage power applications, the gaseous insulation should possess the following properties

- (a) high dielectric strength,
- (b) thermal stability and chemical inactivity towards materials of construction,
- (c) non-flammability and physiological inertness,
- (d) low temperature of condensation,
- (e) good heat transfer(Thermal Conductivity), and
- (f) Commercial availability at moderate cost

Dielectric strength of a gaseous dielectric is the most important property for practical use. The dielectric strength of gases is comparable with those of solid and liquid dielectrics (see Fig. 1.9). In recent years, the dielectric properties of many complex chlorinated and flourinated molecular compounds have also been studied. These are shown in Fig. 1.10. This feature of high dielectric strength of gases is attributed to the molecular complexity and the high rates of electron attachment.

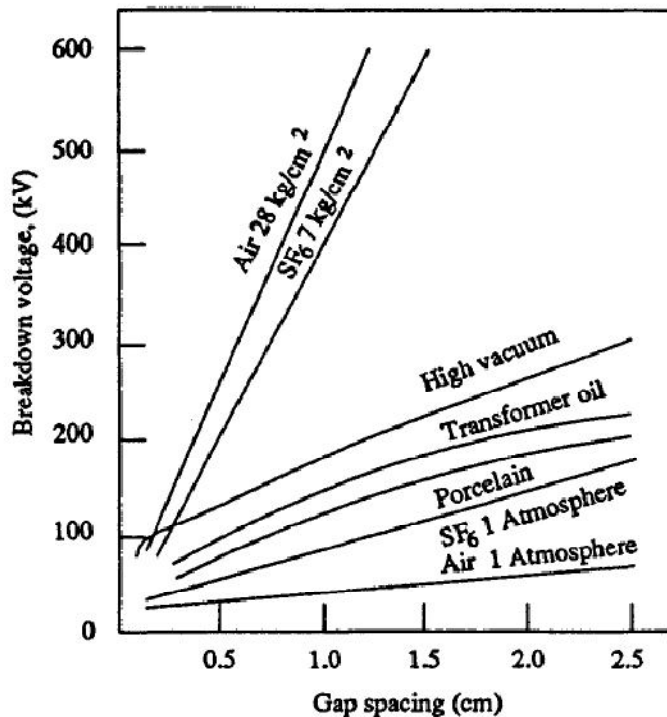

Fig.1.9 DC breakdown strength of typical solid, liquid, gas and vacuum insulations in uniform fields.

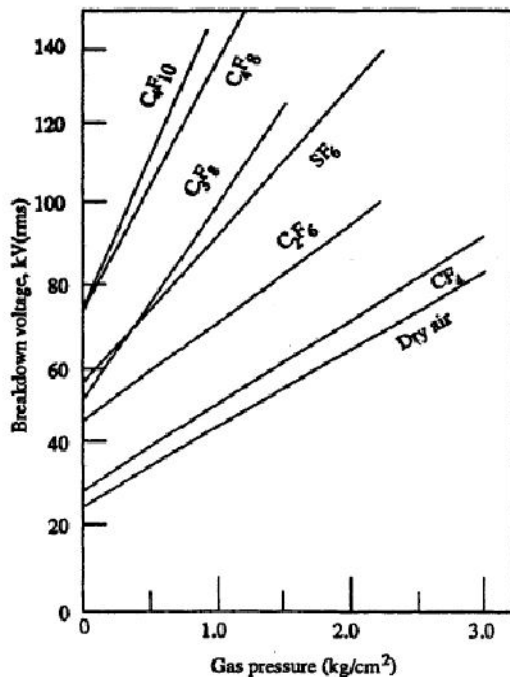

Fig.1.10 Breakdown Strength of insulating gases for 75cm diameter uniform field electrodes having 12mm gap.

SF₆ has high dielectric strength and low liquification temperature, and it can be used over a wide range of operating conditions. SF₆ was also found to have excellent arc-quenching properties. Therefore, it is widely used as an insulating as well as arc-quenching medium in high voltage apparatus such as high voltage cables, current and voltage transformers, circuit breakers and metal encapsulated substations. It may also be noted that addition of 30% SF₆ to air (by volume) increases the dielectric strength of air by 100%. One of the qualitative effects of mixing SF₆ to air is to reduce the overall cost of the gas, and at the same time attaining relatively high dielectric strength or simply preventing the onset of corona at desired operating voltages.

Old End Semester University questions

1. Derive the current growth equation in electronegative gases.
2. Differentiate elastic and inelastic collision. Explain how Townsend criterion enables the breakdown voltage of the gap.
3. In an experiment to measure α for a certain gas, it was found that the steady current is 3.8×10^{-8} A at a voltage of 8 kV and at a distance of 4 mm between the plane electrodes. Keeping the field constant and reducing the distance to 1 mm resulted in a current of 3.8×10^{-9} A.
 - (a) Calculate α ;
 - (b) Calculate the number of electrons emitted from the cathode to anode;
 - (c) Determine the electrode spacing that would lead to an electron multiplication factor of 10^8 .
4. What is Paschen's law? How do you account for the minimum voltage under a given PD condition? State its value for Air

5. Two plane circular electrodes of diameter = 40 cm each and separated by 5 mm gap shows a current of 100 nA on application of 10 kV at NTP. Keeping the applied field constant and reducing the distance to 2 mm results a current of 4000 pA. Calculate Townsend's primary ionization coefficient.

6. Define statistical time lag and formative time lag to breakdown. Show with V-t diagram, that sphere to sphere gap can be used for protection of Bushing as well as Transformers. Rod-rod gap is for Bushing protection only.

MODULE-II

CONDUCTION AND BREAKDOWN IN LIQUID DIELECTRICS

2.1 Introduction

Liquid dielectrics are used mainly spreading through in high voltage cables and capacitors and for filling transformers, circuit breakers, etc. In addition to their function as a dielectric, liquid dielectrics have additional functions in certain applications. For example, liquid dielectrics act as heat transfer agents (i.e. for cooling) in transformers and as arc quenching media in circuit breakers. Petroleum oils are most commonly used as liquid dielectrics. For certain applications Synthetic hydrocarbons and halogenated hydrocarbons and for very high temperature applications, silicone oils and fluorinated hydrocarbons are used. In recent times, certain vegetable oils and esters are also being used.

Liquid dielectrics normally are mixture of hydrocarbons and are weakly polarized. When used for electrical insulation purposes they should be free from moisture, products of oxidation, and other contaminants. The most important factor that affects the electrical strength of insulating oil is the presence of water in the form of fine droplets suspended in the oil. The presence of even 0.01 % water in transformer oil reduces the electrical strength to 20 % of the dry oil value. The dielectric strength of the oil reduces more sharply, if it contains fibrous impurities in addition to water. The three most important properties, of liquid dielectrics are

- (i) the electrical conductivity,
- (ii) dielectric constant, and
- (iii) the dielectric strength.

In addition, the physical and chemical properties such as viscosity, thermal stability, specific gravity, etc. are also important. Examples for the breakdown strength at 20°C on 2.5 mm standard sphere gap are 15 kV/mm for Transformer Oil, 30 kV/mm for Cable Oil, 20 kV/mm for Capacitor Oil, 20-25 kV/mm for Askarels, 30-40 kV/mm for Silicone Oils. In practice, the choice of a liquid dielectric for a given application is made mainly on the basis of its **chemical stability**.

In addition, other factors like *saving of space, cost, previous usage, and susceptibility to the environmental influences* are also considered. In capacitors, replacement of the capacitor oil by askarel spreading through in the overall size of the capacitor by more than 30%. In practice, a liquid found satisfactory over a long period of usage is preferred to a new one. Petroleum liquid are widely used because of their low cost.

2.2 PURE LIQUIDS AND COMMERCIAL LIQUIDS

Pure liquids are those which are chemically pure and do not contain any other impurity even in traces of 1 in 10^9 , and are structurally simple.

Examples of such simple pure liquids are :

n-hexane (C_6H_{14}), n-heptane (C_7H_{16}) and other paraffin hydrocarbons.

By using simple and pure liquids, it is easier to separate out the various factors that influence condition and breakdown in them.

On the other hand, the commercial liquids which are insulating liquids like oils, not chemically pure, normally consist of mixture of complex organic molecules which cannot be easily specified or reproduced in a series of experiments.

2.2.1 Purification

The main impurities in liquid dielectrics are dust, moisture, dissolved, gases and ionic impurities. Various methods employed for purification are filtration (through mechanical filters, spray filters, and electrostatic filters), centrifuging, degassing and distillation, and chemical treatment (adding ion exchange material such as alumina, fuller's earth etc. filtering).

Dust particles when present become charged and reduce the breakdown strength of the liquid dielectrics, and they can be removed by careful filtration.

Liquid will normally contain moisture and dissolved gases in small quantities. Gases like oxygen and carbon dioxide significantly affect the breakdown strength of the liquids, and hence it is necessary to control the amount of gas present. This is done by distillation and degassing.

Ionic impurity in liquids, like water vapor which easily dissociates, leads to very high conductivity and heating of the liquid depending on the applied electric field. Water is removed using drying agents or by vacuum drying.

Sometimes, liquids are shaken with concentrated sulphuric acid to remove wax and residue and washed with caustic soda and distilled water. A commonly used closed-cycle liquid purification system to prepare liquids as per the above requirements is shown in Fig.2.1.

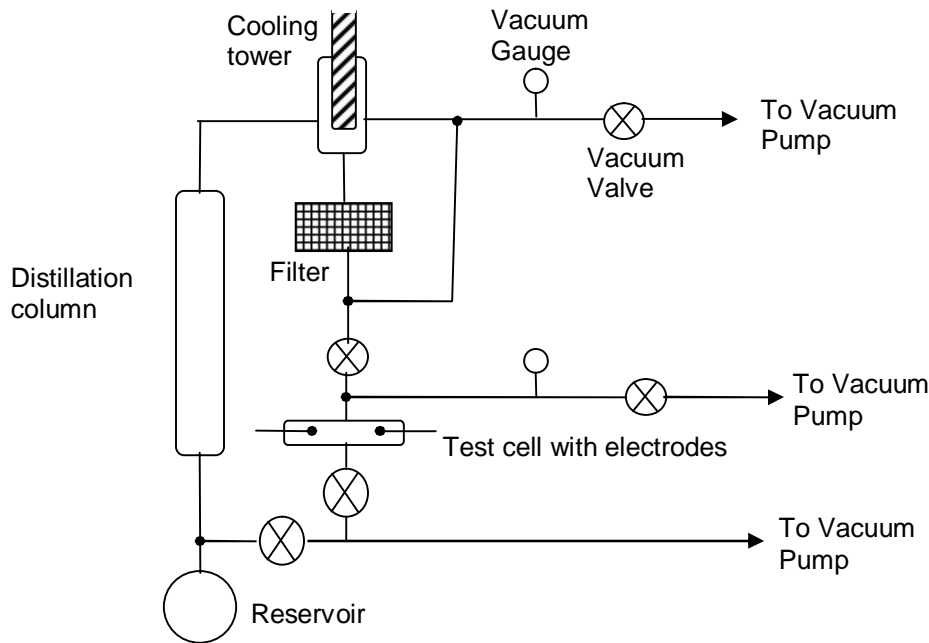

Fig. 2.1 Liquid purification system with test cell.

This system provides for cycling the liquids. The liquid from the reservoir flows through the distillation column where ionic impurities are removed. Water is removed by drying agents or frozen out in the low-temperature bath. The gases dissolve in the liquid are removed by passing them through the cooling tower and/or pumped out by the vacuum pumps. The liquids then pass through the filter where dust particles are removed. The liquid thus purified is then used in the test cell. The used liquid then flows back into the reservoir. The vacuum system thus helps to remove the moisture and other gaseous impurities.

OIL Breakdown Tests

Breakdown tests are normally conducted using test cell. For testing pure liquids, the test cells used are small so that less quantity of liquid is used during testing. Also, test cells are usually an integral part of the purification system as shown in Fig. 3.1. The electrodes used for breakdown voltage measurement are usually spheres of 0.5 to 1 cm in diameter with gap spacing of about 100-200 μm . The gas is accurately controlled by using a micrometer. Electrode separation is very critical in measurement with liquids, and also the electrode surface smoothness and the presence of oxide films have a marked influence on the breakdown strength. The test voltages required for these tests are usually low, of the order of 50-100 kV, because of small electrode spacing. The breakdown strengths and d.c conductivities obtained in pure liquids are very high, of the order of 1 MV/cm and 10^{-18} - 10^{-20} mho/cm respectively, the conductivity being measured at electric field of the order of 1 kV/cm. However, the corresponding values in commercial liquids are relatively low.

2.2 CONDUCTION AND BREAKDOWN IN PURE LIQUIDS

When low electric fields less than 1 kV/cm are applied, conductivities of 10^{-18} - 10^{-20} mho/cm are obtained. These are probably due to the impurities remaining after purification. However, when the fields are high (>100 kV/cm) the currents not only increase rapidly, but also undergo violent fluctuations which will die down after some time. A typical mean value of the conduction current in hexane is shown in Fig. 2.2. This is the condition nearer to breakdown.

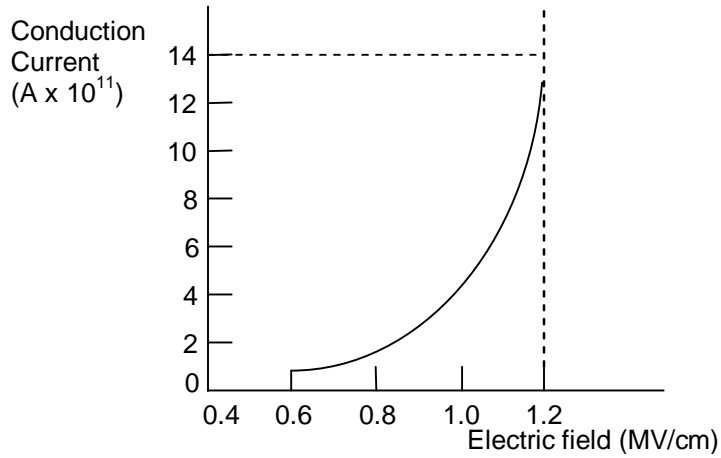

Fig.2.2 Conduction current-electric field characteristics in hexane at high fields

However, if this figure is redrawn starting from very small currents, a current-electric field characteristics as shown in Fig. 2.3, can be obtained. This curve will have three distinct regions as shown. At very low fields the current is due to the dissociation of ions. With intermediate fields the current reaches a saturation value, and at high fields the current generated because of the field-aided electron emission from the cathode gets multiplied in the liquid medium by a Townsend type of mechanism. The current multiplication also occurs from the electrons generated at the interfaces of liquid and impurities. The increase in current by these processes continues till breakdown occurs. The exact mechanism of current growth is not known; however, it appears that the electrons are generated from the cathode by field emission of electrons.

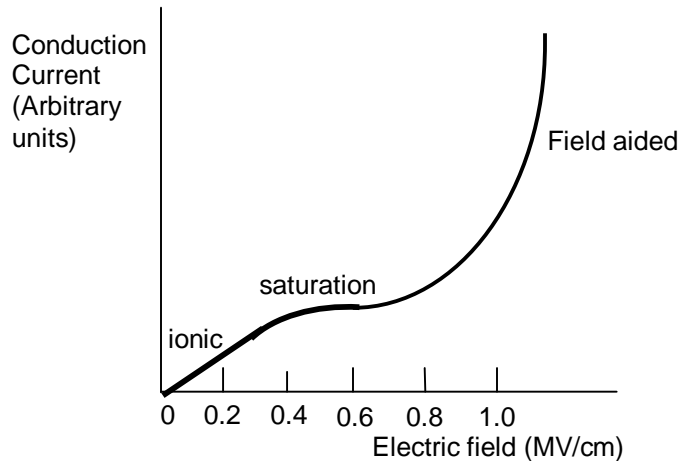

Fig.2.3 Conduction current-electric field characteristics in hydrocarbon liquid

The electrons so liberated get multiple by a process similar to Townsend's primary and secondary ionization in gases. As the breakdown field is approached, the current increases rapidly due to process similar to the primary ionization process and also the positive ions reaching the cathode generate secondary electrons, leading breakdown. The breakdown voltage depends on the field, gap separation, cathode work-function, and the temperature of the cathode. In addition, the liquid viscosity, the liquid temperature, the density, and the molecular structure of the liquid also influence the breakdown strength of the liquid. Typical maximum breakdown strengths of some highly purified liquids and liquefied gases are given in Table 2.1.

| Table 2.1 Maximum Breakdown strength of some liquid | |
|---|------------------------------------|
| Liquid | Maximum breakdown strength (MV/cm) |
| Hexane | 1.1-1.3 |
| Benzene | 1.1 |
| Transformer oil | 1.0 |
| Silicone | 1.0-1.2 |
| Liquid Oxygen | 2.4 |
| Liquid Nitrogen | 1.6-1.9 |
| Liquid Hydrogen | 1.0 |
| Liquid Helium | 0.7 |
| Liquid Argon | 1.1-1.42 |

It has been observed that the increase in breakdown strength is more, if the dissolved gases are electronegative in character (like oxygen). Similarly, the increase in the liquid hydrostatic pressure increases the breakdown strength.

To sum up, this type of breakdown process in pure liquids, called the electronic breakdown, involves emission of electrons at fields greater than 100 kV/cm. This

emission occurs either at the electrode surface irregularities or at the interfaces of impurities and the liquid. These electrons get further multiplied by Townsend's type of primary and secondary ionization processes, leading to breakdown.

2.3 CONDUCTION AND BREAKDOWN IN COMMERCIAL LIQUIDS

As already mentioned commercial insulating liquids are not chemically pure and have impurities like gas bubbles, suspended particles, etc. These impurities reduce the breakdown strength of these liquids considerably. The breakdown mechanisms are also considerably influenced by the presence of these impurities. In addition, when breakdown occurs in these liquids, additional gases and gas bubbles are evolved and solid decomposition products are formed. The electrode surfaces become rough, and at times explosive sounds are heard due to the generation of impulsive pressure through the liquid. The breakdown mechanism in commercial liquids is dependent on several factors, such as, the nature and condition of the electrodes, the physical properties of the liquid, and the impurities and gases present in the liquid. Several theories have been proposed to explain the breakdown in liquids, and they are classified as follows:

- a) **Electronic breakdown**
- b) **Suspended Particle Mechanism**
- c) **Cavitation and Bubble Mechanism**
- d) **Stressed Oil Volume Mechanism**

2.3.1 *Electronic breakdown*

Both the field emission and the field-enhanced thermionic emission mechanisms discussed earlier have been considered responsible for the current at the cathode. Conduction studies in insulating liquids at high fields show that most experimental data for current fit well the Schottky-type equation in which the current is temperature dependent. Breakdown measurements carried out over a wide range of temperatures, however, show little temperature dependence. This suggests that the cathode process is field emission rather than thermionic emission. It is possible that the return of positive ions and particularly positively charged foreign particles to the cathode will cause local field enhancement and give rise to local electron emission. Once the electron is injected into the liquid it gains energy from the applied field. In the electronic theory of breakdown it is assumed that some electrons gain more energy from the field than they lose in collisions with molecules. These electrons are accelerated until they gain sufficient energy to ionize molecules on collisions and initiate avalanche. The condition for the onset of electron avalanche is obtained by equating the gain in energy of an electron over its mean free path to that required for ionization of the molecule.

$$eE\lambda = ch\nu$$

where E is the applied field, λ the electron mean free path, $h\nu$ the quantum of energy lost in ionizing the molecule and c an arbitrary constant. The electronic theory satisfactorily predicts the relative magnitude of breakdown strength of liquids, but the observed formative time lags are much longer than predicted by electronic theory.

2.3.2 **Suspended Particle Theory**

Solid impurities may be present in the liquid either as fibres or as dispersed solid particles and their presence of solid impurities cannot be avoided. The permittivity of these particles ϵ_1 will be different from the permittivity of the liquid ϵ_2 . If we consider these impurities to be spherical particles of radius r , and if the applied field is E , then the particles experience of force F , where

$$F = r^3 \frac{\epsilon_1 - \epsilon_2}{\epsilon_1 + 2\epsilon_2} E \frac{dE}{dX} \quad (2.1)$$

This force is directed towards areas of maximum stress, if $\epsilon_2 > \epsilon_1$, for example, in the case of the presence of solid particles like paper in the liquid. On the other hand, if only gas bubbles are present in the liquid, i.e. $\epsilon_2 < \epsilon_1$, the force will be in the direction of areas of lower stress (opposite direction). If the voltage is continuously applied (d.c) or the duration of the voltage is long (a.c), then this force drives the particles towards the area of maximum stress. If the number of particles is large, they become aligned due to these forces, and thus form a stable chain bridging the electrode gap causing a breakdown between the electrodes.

The force given by eqn (2.1) increases as the permittivity of the suspended particle (ϵ) increases, and for a conducting particle for which $\epsilon_1 \rightarrow \infty$ the force becomes

$$F = F_\infty = r^3 E \text{ grad } E$$

Thus the force will urge the particle to move to the strongest region of the field.

In a uniform field gap or sphere gap of small spacing the strongest field is in the uniform region. In this region $\text{grad } E$ is equal to zero so that the particle will remain in equilibrium there. Accordingly, particles will be dragged into the uniform field region. If the permittivity of the particle is higher than that of the medium, then its presence in the uniform field region will cause flux concentration at its surface. Other particles will be attracted into the region of higher flux concentration and in time will become aligned head to tail to form a bridge across the gap. The field in the liquid between the particles will be enhanced, and if it reaches critical value breakdown will follow.

The movement of particles by electrical force is opposed by viscous drag, and since the particles are moving into the region of high stress, diffusion must also be taken into account.

If there is only a single conducting particle between the electrodes, it will give rise to local field enhancement depending on its shape. If this field exceeds the breakdown strength of the liquid, local breakdown will occur near the particle, and this will result in the formation of gas bubbles which may lead to the breakdown of the liquid.

The value of the breakdown strength of the liquids containing solid impurities was found to be much less than the values for pure liquids. The impurity particles reduce the breakdown strength, and it was also observed that the larger the size of the particles the lower were the breakdown strengths.

2.3.3. Cavitation and the Bubble Theory

It was experimentally observed that in many liquids, the breakdown strength depends strongly on the applied hydrostatic pressure, suggesting that a change of phase of the medium is involved in the breakdown process, which in other words means that a kind of

vapor bubble formed is responsible for breakdown. The following processes have been suggested to be responsible for the formation of the vapor bubbles:

- a) Gas pockets at the surface of the electrodes;
- b) electrostatic repulsive forces between space charges which may be sufficient to overcome the surface tension;
- c) gaseous products due to the dissociation of liquid molecules by electron collisions; and
- d) Vaporization of the liquid by corona type discharges from sharp points and irregularities on the electrode surfaces.

Once a bubble is formed it will elongated (long and thin) in the direction of the electric field under the influence of electrostatic forces. The volume of the bubble remains constant during elongation. Breakdown occurs when the voltage drop along the length of the bubble becomes equal to the minimum value on the Paschen's curve for the gas in the bubble.

The electric field in a spherical gas bubble which is immersed in a liquid of permittivity ϵ_2 is given by $E_b = 3E_0 / (\epsilon_2 + 2)$; where E_0 is the field in the liquid in the absence of the bubble. When the field E_b becomes equal to the gaseous ionization field, discharge takes place which will lead to decomposition of the liquid and breakdown may follow. Kao has developed more accurate expression for the breakdown field as

$$E_0 = \frac{1}{(\epsilon_1 - \epsilon_2)} \left[\frac{2\pi\sigma(2\epsilon_1 + \epsilon_2)}{r} \left\{ \sqrt{\frac{V_b}{(2rE_0)}} - 1 \right\} \right]^{\frac{1}{2}} \quad (2.2)$$

where σ is the surface tension of the liquid, ϵ_1 is the permittivity of the liquid, ϵ_2 is the permittivity of the gas bubble, r is the initial radius of the bubble assumed as a sphere and V_b is the voltage drop in the bubble (corresponding to minimum on the Paschen's curve). From this equation it can be seen that the breakdown strength depends on the initial size of the bubble which in turn is influenced by the hydrostatic pressure and temperature of the liquid. But this theory does not take into account the production of the initial bubble and hence the results given by this theory do not agree well with the experimental results.

In general, the cavitation and bubble theories try to explain the highest breakdown strengths obtainable, considering the cavities or bubbles formed in the liquid dielectrics.

2.3.4. Stressed Oil Volume Theory

In commercial liquids where minute traces of impurities are present, the breakdown strength is determined by the "largest possible impurity" or "weak link". On a statistical basis it was proposed that the electrical breakdown strength of the oil is defined by the weakest region in the oil, namely, the region which is stressed to the maximum and by the volume of oil included in that region. In non-uniform fields, the stressed oil volume is taken as the volume which is contained between the maximum stress (E_{\max}) contour

and $0.9 (E_{\max})$ contour. According to this theory the breakdown strength is inversely proportional to the stressed oil volume.

The breakdown voltage is highly influenced by the gas content in the oil, the viscosity of the oil, and the presence of other impurities. These being uniformly distributed, increase in the stressed oil volume consequently results in a reduction in the breakdown voltage. The variation of the breakdown voltage stress with the stressed oil volume is shown in Fig. 2.4.

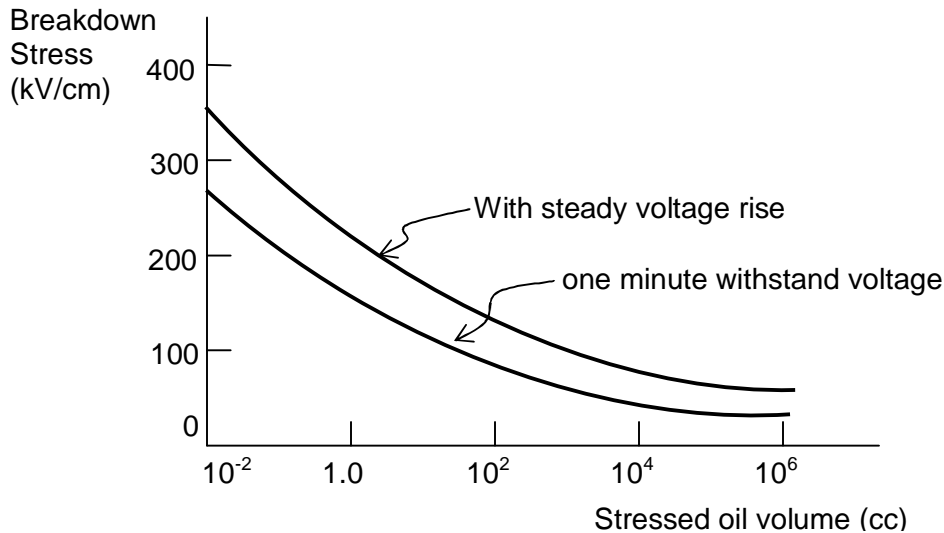

Fig 2.4 Power frequency (50 Hz) a.c breakdown stress as function of stressed oil volume

2.4 CONCLUSIONS

All the theories discussed above do not consider the dependence of breakdown strength on the gap length. They all try to account for the maximum obtainable breakdown strength only. However, the experimental evidence showed that the breakdown strength of a liquid depends on the gap length, given by the following expression,

$$V_b = Ad^n \quad \text{where, } A=\text{constant, and} \\ n=\text{constant, always less than 1.}$$

The breakdown voltage also depends on the nature of the voltage, the mode in which the voltage is applied, and the time of application. The above relationship is of practical importance, and the electrical stress of given oil used in design is obtained from this. During the last ten years, research work is directed on the measurements of discharge inception (starting) levels in oil and the breakdown strengths of large volumes of oil under different conditions.

It may be summarized that the actual mechanism of breakdown in oil is not a simple phenomenon and the breakdown voltages are determined by experimental investigations only. Electrical stresses obtained for small volumes should not be used in the case of large volumes.

QUESTIONS

1. Explain the phenomena of electrical conduction in liquids. How does it differ from those in gases?
2. What are the commercial liquid dielectrics, and how are they different from pure liquid dielectrics?
3. What are the factors that influence conduction in pure liquid dielectrics and in commercial liquid dielectrics?
4. Explain the various theories that explain breakdown in commercial liquid dielectrics.
5. What is “stressed oil volume theory”, and how does it explain breakdown in large volumes of commercial liquid dielectrics?
6. State the electrical properties which are essential for electrical performance of Liquid Dielectrics.

BREAKDOWN IN SOLID DIELECTRICS

3.1 INTRODUCTION

Solid dielectric materials are used in all kinds of electrical circuits and devices to insulate one current carrying part from another when they operate at different voltages. A good dielectric should have low dielectric loss, high mechanical strength, should be free from gaseous inclusion, and moisture, and be resistant to thermal and chemical deterioration. Solid dielectrics have higher breakdown strength compared to liquids and gases.

Studies of the breakdown of solid dielectrics are of extreme importance in insulation studies. When breakdown occurs, solids get permanently damaged while gases fully and liquids partly recover their dielectric strength after the applied electric field is removed.

The mechanism of breakdown is a complex phenomenon in the case of solids, and varies depending on the time of application of voltage as shown in Fig. 3. 1.

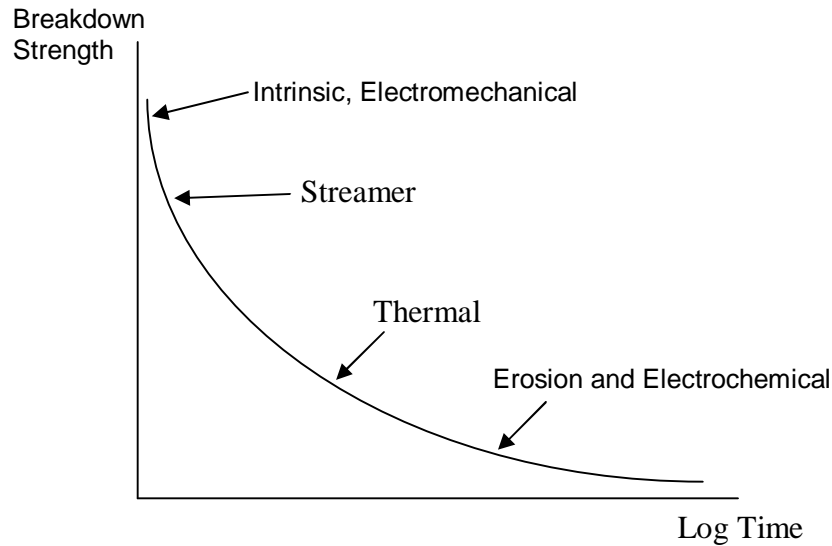

Fig.3.1 Variation of breakdown strength with time after application of voltage

The various breakdown mechanisms can be classified as follows:

- (a) Intrinsic or ionic breakdown,
- (b) electromechanical breakdown,
- (c) failure due to treeing and tracking,
- (d) thermal breakdown,
- (e) electrochemical breakdown, and
- (f) breakdown due to internal discharges.

3.2 INTRINSIC BREAKDOWN

When voltages are applied only for short durations of the order of 10^8 s the dielectric strength of a solid dielectric increases very rapidly to an upper limit called the intrinsic electric strength. Experimentally, this highest dielectric strength can be obtained only under the best experimental conditions when all extraneous influences have been isolated and the value depends only on the structure of the material and the temperature. The maximum electrical strength recorder is 15 MV/cm for polyvinyl-alcohol at -196°C . The maximum strength usually obtainable ranges from 5 MV/cm.

Intrinsic breakdown depends upon the presence of free electrons which are capable of migration through the lattice of the dielectric. Usually, a small number of conduction electrons are present in solid dielectrics, along with some structural imperfections and small amounts of impurities. The impurity atoms, or molecules or both act as traps for the conduction electrons up to certain ranges of electric fields and temperatures. When these ranges are exceeded, additional electrons in addition to trapped electrons are released, and these electrons participate in the conduction process.

Based on this principle, two types of intrinsic breakdown mechanisms have been proposed.

i) Electronic Breakdown

Intrinsic breakdown occurs in time of the order of 10^{-8} s and therefore is assumed to be electronic in nature. The initial density of conduction (free) electrons is also assumed to be large, and electron-electron collisions occur. When an electric field is applied, electrons gain energy from the electric field and cross the forbidden energy gap from the valence band to the conduction band. When this process is repeated, more and more electrons become available in the conduction band, eventually leading to breakdown.

ii) Avalanche or Streamer Breakdown

This is similar to breakdown in gases due to cumulative ionization. Conduction electrons gain sufficient energy above a certain critical electric field and cause liberation of electrons from the lattice atoms by collision. Under uniform field conditions, if the electrodes are embedded in the specimen, breakdown will occur when an electron avalanche bridges the electrode gap.

An electron within the dielectric, starting from the cathode will drift towards the anode and during this motion gains energy from the field and loses it during collisions. When the energy gained by an electron exceeds the lattice ionization potential, an additional electron will be liberated due to collision of the first electron. This process repeats itself resulting in the formation of an electron avalanche. Breakdown will occur, when the avalanche exceeds a certain critical size.

In practice, breakdown does not occur by the formation of a single avalanche itself, but occurs as a result of many avalanches formed within the dielectric and extending step by step through the entire thickness of the material.

3.3 ELECTROMECHANICAL BREAKDOWN

When solid dielectrics are subjected to high electric fields, failure occurs due to electrostatic compressive forces which can exceed the mechanical compressive strength. If the thickness of the specimen is d_0 and is compressed to thickness d under an applied voltage V , then the electrically developed compressive stress is in equilibrium if

$$\epsilon_0 \epsilon_r = \frac{V^2}{2d^2} = Y \ln \left[\frac{d_0}{d} \right] \quad (3.1) \quad \text{where } Y \text{ is the Young's modulus. From Eq. (3.1)}$$

$$V^2 = d^2 \left[\frac{2Y}{\epsilon_0 \epsilon_r} \right] \ln \left[\frac{d_0}{d} \right] \quad (3.2)$$

Usually, mechanical instability occurs when

$$d/d_0 = 0.6 \text{ or } d_0/d = 1.67$$

Substituting this Eq.3.2, the highest apparent electric stress before breakdown,

$$E_{\max} = \frac{V}{d_0} = 0.6 \left[\frac{Y}{\epsilon_0 \epsilon_r} \right]^{\frac{1}{2}} \quad (3.3)$$

The above equation is only approximate as Y depends on the mechanical stress. Also when the material is subjected to high stresses the theory of elasticity does not hold good, and plastic deformation has to be considered.

3.4 THERMAL BREAKDOWN

In general, the breakdown voltage of a solid dielectric should increase with its thickness. But this is true only up to a certain thickness above which the heat generated in the dielectric due to the flow of current determines the conduction.

When an electric field is applied to a dielectric, conduction current however small it may be, flows through the material. The current heats up the specimen and the temperature rise. The heat generated is transferred to the surrounding medium by conduction through the solid dielectric and by radiation from its outer surfaces. Equilibrium is reached when the heat used to raise the temperature of the dielectric, plus the heat radiated out, equals the heat generated. The heat generated under d. c. stress E is given as

$$W_{\text{d.c.}} = E^2 \sigma \text{ W/cm}^3 \quad (3.4) \text{ where } \sigma \text{ is the d. c. conductivity of the specimen.}$$

Under a. c. fields, the heat generated

$$W_{\text{a.c.}} = \frac{E^2 f_{\epsilon_r} \tan \delta}{1.8 \times 10^{12}} \text{ W/cm}^3 \quad (3.5) \text{ where, } f = \text{frequency in Hz, } \delta = \text{loss angle of the}$$

dielectric material, and E= rms value. The heat dissipated (W_r) is given by

$$W_r = C_v \frac{dT}{dt} + \text{div} (K \text{ grad } T) \quad (3.6) \text{ where, } C_v = \text{specific heat of the specimen,}$$

T = temperature of the specimen, K = thermal conductivity of the specimen, and t = time over which the heat is dissipated.

Equilibrium is reached when the heat generated ($W_{\text{d.c.}}$ or $W_{\text{a.c.}}$) becomes equal to the heat dissipated (W_r). In actual practice there is always some heat that is radiated out.

Breakdown occurs when $W_{\text{d.c.}}$ or $W_{\text{a.c.}}$ exceeds W_r . The thermal instability condition is shown in Fig. 3.2. Here, the heat lost is shown by a straight line, while the heat generated at fields E_1 and E_2 is shown by separate curves. At field E_2 breakdown occurs both at temperatures T_A and T_B heat generated is less than the heat lost for the field E_2 , and hence the breakdown will not occur.

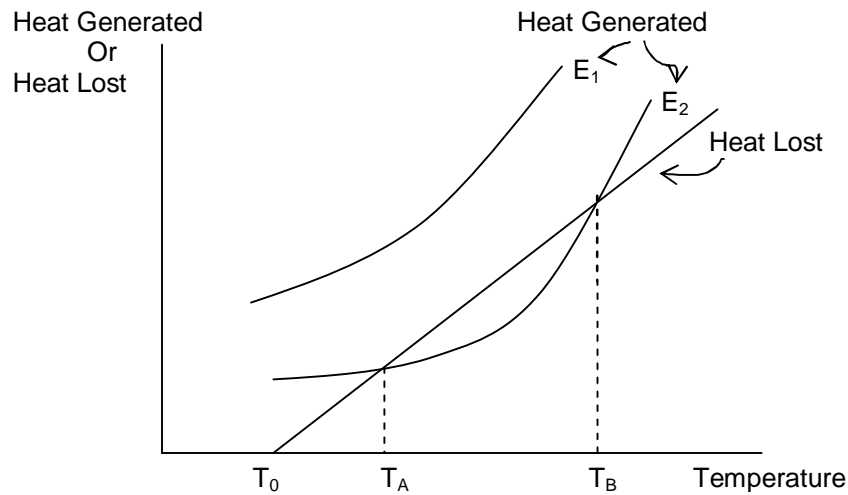

Fig.3.2 Thermal instability in solid dielectrics

The thermal breakdown voltages of various materials under d.c. and a.c. fields are shown in the table 3.1

Table 3.1

| Material | Maximum thermal breakdown stress in MV/cm | |
|------------------------------|---|---------|
| | d.c. | a.c. |
| Muscovite mica | 24 | 7.18 |
| Rock salt | 38 | 1.4 |
| High grade porcelain | - | 2.8 |
| H.V. Steatite | - | 9.8 |
| Quartz-perpendicular to axis | 1200 | - |
| -parallel to axis | 66 | - |
| Capacitor paper | - | 3.4-4.4 |
| Polythene | - | 3.5 |
| Polystyrene | - | 5.0 |

It can be seen from this table 3.1 that since the power loss under a.c. fields is higher, the heat generation is also high, and hence the thermal breakdown stresses are lower under a.c. conditions than under d.c. conditions.

3.5 BREAKDOWN OF SOLID DIELECTRICS IN PRACTICE

There are certain types of breakdown which do not come under either intrinsic breakdown, but actually occur after prolonged operation. These are, for example, breakdown due to tracking in which dry conducting tracks act as conducting paths on the

insulator surfaces leading to gradual breakdown along the surface of the insulator. Another type of breakdown in this category is the electrochemical breakdown caused by chemical transformations such as electrolysis, formation of ozone, etc. In addition, failure also occurs due to partial discharges which are brought about in the air pockets inside the insulation. This type of breakdown is very important impregnated paper insulation used in high voltage cables and capacitors.

3.5.1 Chemical and Electrochemical Deterioration and Breakdown

In the presence of air and other gases some dielectric materials undergo chemical changes when subjected to continuous stresses. Some of the important chemical reactions that occur are:

-Oxidation: In the presence of air or oxygen, material such as rubber and polyethylene undergo oxidation giving rise to surface cracks.

-Hydrolysis: When moisture or water vapor is present on the surface of a solid dielectric, hydrolysis occurs and the material loses their electrical and mechanical properties. Electrical properties of materials such as paper, cotton tape, and other cellulose materials deteriorate very rapidly due to hydrolysis. Plastics like polyethylene undergo changes, and their service life considerably reduces.

-Chemical Action: Even in the absence of electric fields, progressive chemical degradation of insulating materials can occur due to a variety of processes such as chemical instability at high temperatures, oxidation and cracking in the presence of air and ozone, and hydrolysis due to moisture and heat. Since different insulating materials come into contact with each other in any practical reactions occur between these various materials leading to reduction in electrical and mechanical strengths resulting in a failure.

The effects of electrochemical and chemical deterioration could be minimized by carefully studying and examining the materials. High soda content glass insulation should be avoided in moist and damp conditions, because sodium, being very mobile, leaches to the surface giving rise to the formation of a strong alkali which will cause deterioration. It was observed that this type of material will lose its mechanical strength within 24 hrs, when it is exposed to atmospheres having 100% relative humidity at 70⁰ C. In paper insulation, even if partial discharges are prevented completely, breakdown can occur due to chemical degradation. The chemical and electrochemical deterioration increases very rapidly with temperature, and hence high temperatures should be avoided.

3.5.2 Breakdown Due to Treeing and Tracking

When a solid dielectric subjected to electrical stresses for a long time fails, normally two kinds of visible markings are observed on the dielectric material. They are:

a) the presence of a conducting path across the surface of the insulation:

b) a mechanism whereby leakage current passes through the conducting path finally leading to the formation of a spark. Insulation deterioration occurs as a result of these sparks.

The spreading of spark channels during tracking, in the form of the branches of a tree is called treeing.

Consider a system of a solid dielectric having a conducting film and two electrodes on its surface. In practice, the conducting film very often is formed due to moisture. On application of voltage, the film starts conducting, resulting in generation of heat, and the surface starts becoming dry. The conducting film becomes separate due to drying, and so sparks are drawn damaging the dielectric surface. With organic insulating materials such as paper and bakelite, the dielectric carbonizes at the region of sparking, and the carbonized regions act as permanent conducting channels resulting in increased stress over the rest of the region. This is a cumulative process, and insulation failure occurs when carbonized tracks bridge the distance between the electrodes. This phenomenon, called tracking is common between layers of bakelite, paper and similar dielectrics built of laminates.

On the other hand treeing occurs due to the erosion of material at the tips of the spark. Erosion results in the roughening of the surfaces, and hence becomes a source of dirt and contamination. This causes increased conductivity resulting either in the formation of conducting path bridging the electrodes or in a mechanical failure of the dielectric.

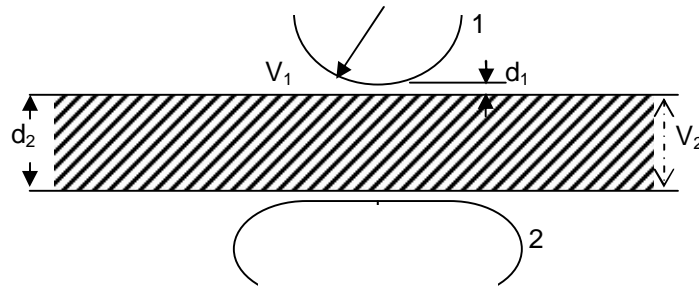

Fig.3.3 Arrangement for study of treeing phenomena.1 and 2 are electrodes.

When a dielectric material lies between two electrodes as shown in Fig. 3.3, there is possibility for two different dielectric media, the air and the dielectric, to come series. The voltages across the two media are as shown (V_1 across the air gap, and V_2 across the dielectric). The voltage V_1 across the air gap is given as,

$$V_1 = \frac{V \cdot d_1}{d_1 + \left(\frac{\epsilon_1}{\epsilon_2}\right) d_2} \quad (3.7) \quad \text{where } V \text{ is the applied voltage.}$$

Since $\epsilon_2 > \epsilon_1$ most of the voltage appears across d_1 , the air gap. Sparking will occur in the air gap and charge accumulation takes place on the surface of the insulation. Sometimes the spark erodes the surface of the insulation. As time passes, break-down channels spread through the insulation in an irregular “tree” like fashion leading to the formation of conducting channels. This kind of channeling is called treeing.

Under a.c. voltage conditions treeing can occur in a few minute or several hours. Hence, care must be taken to see that no series air gaps or other weaker insulation gaps are formed.

Usually, tracking occurs even at very low voltage of the order of about 100 V, whereas treeing requires high voltages. For testing of tracking, low and medium voltage tracking tests are specified. These tests are done at low voltages but for times of about 100 hr or more. The insulation should not fail. Sometimes the tests are done using 5 to 10 kV with shorter durations of 4 to 6 hour. The numerical value that initiates or causes the formation of a track is called “tracking index” and this is used to qualify the surface properties of dielectric materials.

Treeing can be prevented by having clean, dry, and undamaged surfaces and a clean environment. The materials chosen should be resistant to tracking. Sometimes moisture repellent greases are used. But this needs frequent cleaning and regreasing. Increasing creeping distances should prevent tracking, but in practice the presence of moisture films defeat the purpose.

Usually, treeing phenomena is observed in capacitors and cables, and extensive work is being done to investigate the real nature and causes of this phenomenon.

3.5.3 Breakdown Due to Internal Discharges

Solid insulating materials, and to a lesser extent liquid dielectrics contain voids or cavities within the medium or at the boundaries between the dielectric and the electrodes. These voids are generally filled with a medium of lower dielectric strength, and the dielectric constant of the medium in the voids is lower than that of the insulation. Hence, the electric field strength in the voids is higher than that across the dielectric. Therefore, even under normal working voltages the field in the voids may exceed their breakdown value, and breakdown may occur.

Let us consider a dielectric between two conductors as shown in Fig. 3.4.a. If we divide the insulation into three parts, an electrical network of $C_1, C_2,$ and C_3 can be formed as shown in Fig. 3.4.b. In this, C_1 represents the capacitance of the void or cavity, C_2 is the capacitance of the dielectric which is in series with the void, and C_3 is the capacitance of the dielectric

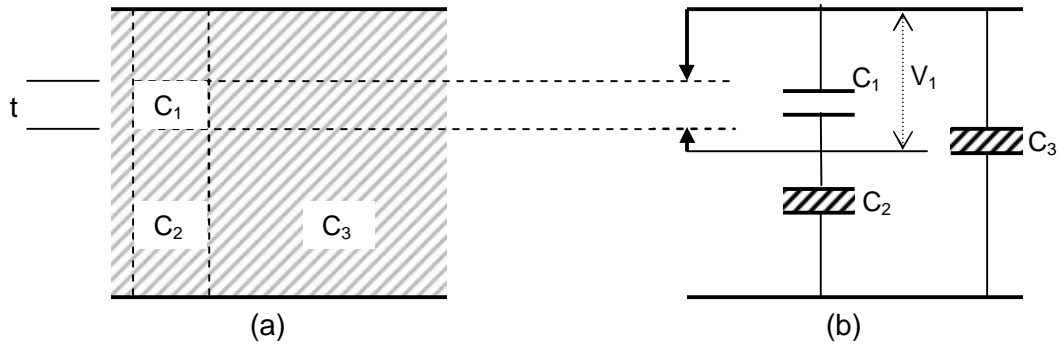

Fig.3.4 Electrical discharge in a cavity and its equivalent circuit

When the applied voltage is V , the voltage across the void, V_1 is given by the same equation as (3.7)

$$V_1 = \frac{Vd_1}{d_1 + \left(\frac{\epsilon_0}{\epsilon_1}\right)d_2} \quad \text{where } d_1 \text{ and } d_2 \text{ are the thickness of the void and the dielectric,}$$

respectively, having permittivities ϵ_0 and ϵ_1 . Usually $d_1 \ll d_2$, and if we assume that the cavity is filled with a gas, then

$$V_1 = V_{er} \left(\frac{d_1}{d_2}\right) \quad (3.8) \quad \text{where } \epsilon_r \text{ is the relative permittivity of the dielectric.}$$

When a voltage V is applied, V_1 reaches the breakdown strength of the medium in the cavity (V_i) and breakdown occurs. V_i is called the “discharge inception voltage”. When the applied voltage is a.c., breakdown occurs on both the half cycles and the number of discharges will depend on the applied voltage. When the first breakdown across the cavity occurs the breakdown voltage across it becomes zero. When once the voltage V_1 becomes zero, the spark gets extinguished and again the voltage rises till breakdown occurs again. This process repeats again and again, and current pulses will be obtained both in the positive and negative half cycles.

These internal discharges (also called partial discharges) will have the same effect as “treeing” on the insulation. When the breakdown occurs in the voids, electrons and positive ions are formed. They will have sufficient energy and when they reach the void surfaces they may break the chemical bonds. Also, in each discharge there will be some heat dissipated in the cavities, and this will carbonize the surface of the voids and will caused erosions of the material. Channels and pits formed on the cavity surfaces increase the conduction. Chemical degradation may also occur as a result of the activate discharge products formed during breakdown.

All these effect will result in a gradual erosion of the material and consequent reduction in the thickness of insulation leading to breakdown. The life of the insulation with internal discharges depends upon the applied voltage and the number of

discharges. Breakdown by this process may occur in a few or days or may take a few years.

3.6 BREAKDOWN OF COMPOSITE INSULATION

A single material rarely constitutes the insulation in equipment. Two or more insulating materials are used either due to design considerations or due to practical difficulties of fabrication.

In certain cases the behavior of the insulation system can be predicted by the behavior of the components. But in most cases, the system as a whole has to be considered. The following considerations determine the performance of the system as a whole:

- (i) The stress distribution at different parts of the insulation system is distorted due to the component dielectric constant and conductivities,
- (ii) the breakdown characteristics at the surface are affected by the insulation boundaries of various components,
- (iii) the internal or partial discharge products of one component invariably affect the other components in the system, and
- (iv) the chemical ageing products of one component also affect the performance of other components in the system.

Another important consideration is the economic life of the system; the criterion being the ultimate breakdown of the solid insulation. The end point is normally reached by through puncture, thermal runaway, electrochemical breakdown, or mechanical failure leading to complete electrical breakdown of the system. Hence, tests for assessing the life of insulation (ageing) are very necessary.

Ageing is the process by which the electrical and mechanical properties of insulation normally becomes worse in condition (deteriorate) with time. Ageing occurs mainly due to oxidation, chemical degradation, irradiation, and electron and ion bombardment on the insulation. Tracking is another process by which ageing of the insulation occurs. Usually partial discharge tests are used in ageing studies to estimate the discharge magnitudes, discharge inception, and extinction voltages. Change of loss angle ($\tan \delta$) during electrical stressing provides information of the deterioration occurring in insulation systems. The knowledge of the mechanical stresses in the insulation, controlling of the ambient conditions such as temperature and humidity, and a study of the gaseous products evolved during ageing processes will also help to control the breakdown process in composite insulation. Finally, stress control in insulation systems to avoid high electric stress regions is an important factor in controlling the failure of insulation systems.

Questions

3.1 What do you understand by 'intrinsic strength' of a solid dielectric? How does breakdown occur due to electrons in solid dielectric?

3.2 What is 'thermal breakdown' in solid dielectrics, and how is practically more significant than other mechanism?

3.3 How does the 'internal discharge' phenomenon lead to breakdown in solid dielectrics?

3.4 How do the temperature and moisture affect the breakdown strength of solid dielectrics?

3.5. Determine the specific heat generated in the test specimen due to dielectric loss if the dielectric constant and loss angle of the specimen are 3.8 and 0.0085 respectively. The electric field is 40kV/cm at 50HZ.

37 SOLID DIELECTRICS USED IN PRACTICE (Not in course but useful in GATE/IES and other PSU Examns)

Solid insulating materials are used in all kinds of electrical circuits and devices to insulate one current carrying part from another when they operate at different voltages. A good insulator should be of low dielectric loss, having high mechanical strength, free from gaseous inclusions and moisture, and should also be resistant to thermal and chemical deterioration.

Solid dielectrics vary widely in their origin and properties. They may be natural organic substances, such as paper, cloth, rubber, etc. or inorganic materials, such as mica, glass and ceramics or synthetic materials like plastics. Some of the important materials and their properties are discussed here.

3.7.1 Paper

The kind of paper normally employed for insulation purposes is a special variety known as tissue paper or Kraft paper. The thickness and density of paper vary depending on the application. Low-density paper (0.8 gms/cm³) is preferred in high frequency capacitors and cables, while medium density paper is used in power capacitors. High-density papers are preferable in d.c. and energy storage capacitors and for the insulation of d.c. machines.

Paper is hygroscopic. Therefore, it has to be dried and impregnate with impregnants, such as mineral oil, chlorinated diphenyl and vegetable oils. The relative dielectric constant of impregnated paper depends upon the permittivity of cellulose of which the paper is made, and permittivity of the impregnant and the density of the paper. Table 3.2 gives the dielectric constants for different densities of paper impregnated with different oils.

Table 3.2 Dielectric constant of paper with different densities

| Impregnant | Density (g/cm ³) | | |
|--|------------------------------|------|------|
| | 0.8 | 1.0 | 1.2 |
| Trichlorodiphenyl at 20°C $\epsilon = 6.1$ | 6.28 | 6.30 | 6.40 |
| Trichlorodiphenyl at 50°C $\epsilon = 5.6$ | 6.0 | 6.14 | 6.24 |
| Pentachlorodiphenyl at 20°C $\epsilon = 5.7$ | 5.71 | 5.88 | 6.06 |
| Transformer oil $\epsilon = 2.2$ | 3.26 | 3.72 | 4.30 |

When very thin (thickness 8-20 μm) paper is used, it is very essential to see that the number of conducting particles on the surface of the paper is minimum. The conventional method of detecting conducting particles is by means of using a roller and place, the conduction being indicated by means of head phones.

3.7.2 Fibers

Fibers when used for electrical purposes will have the ability to combine strength and durability with extreme fitness and durability with extreme fitness and flexibility. The fibers used are both natural and man-made. They include cotton, jute, flax, wool, silk (natural fibers), rayon, nylon, terylene, teflon and fiberglass.

The properties of fibrous materials depend on the temperature and humidity. Figures 4.5 and 4.6 show the variation of ϵ_r and $\tan \delta$ of various fibrous materials as a function of the frequency. It can be observed from these figures that ϵ_r decreases with frequency, while $\tan \delta$ is higher lower frequencies. Most of the perfectly-dried fibers have a dielectric constant between 3 and 8. The presence of ionic impurities (e.g., salt) considerably reduces the electrical resistance of the fiber. Artificial fibers, such as terylene and fiberglass absorb very little water and hence have very high resistance.

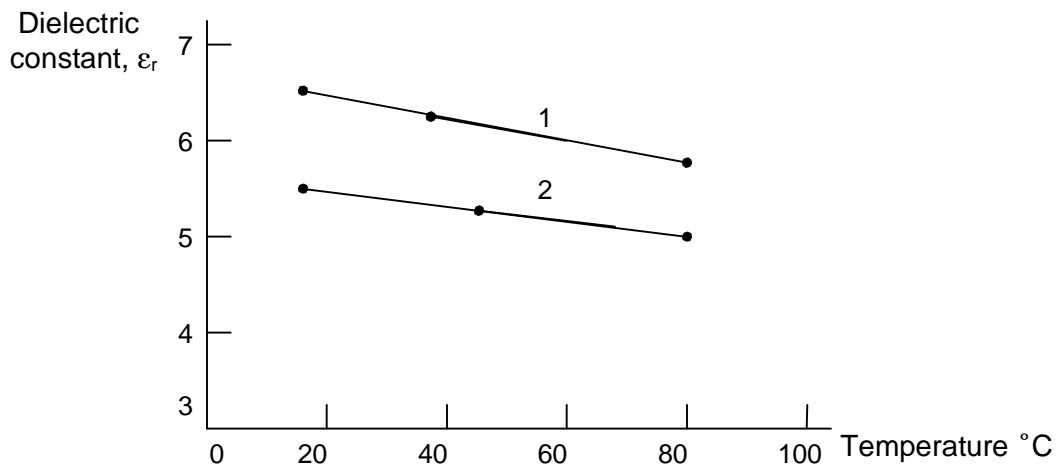

Fig.3.5 Variation of dielectric constant, ϵ_r with temperature for paper
1. Trichlorodiphenyl impregnated paper, 2. Pentachlorodiphenyl impregnated paper

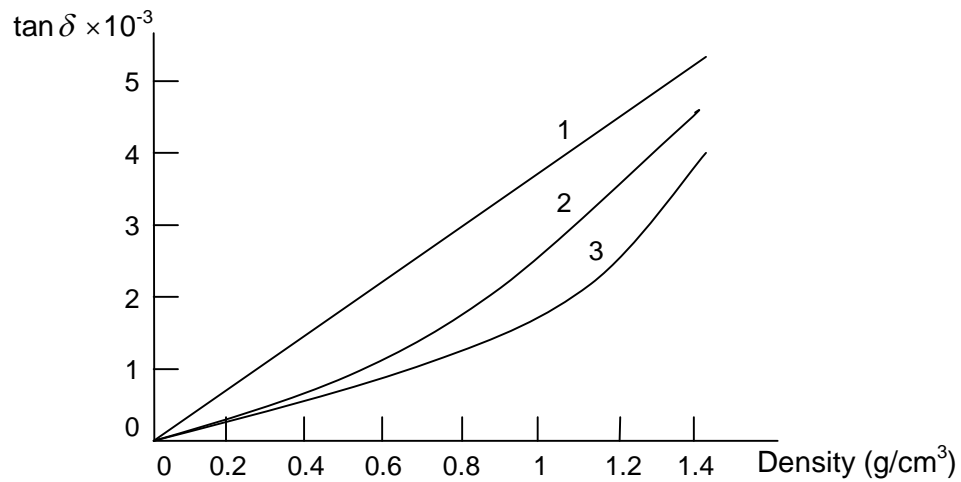

Fig.3.6 Variation of $\tan \delta$ with the density of paper
 1. Trichlorodiphenyl impregnated paper, 2. Mineral oil impregnated paper 3. Dry paper

Table 3.3 gives the density, ϵ_r , and $\tan \delta$ of various fibers.

Table 3.3

| Fibers | Density | ϵ_r | $\tan \delta$ |
|-------------------------|---------|--------------|---------------|
| Vegetable fiber-Natural | | | |
| Cotton | 1.53 | 4.4-7.3 | 0.120 |
| Flax | 1.53 | 4.4-7.3 | 0.120 |
| Jute | 1.53 | 4.4-7.3 | 0.120 |
| Animal fiber-Natural | | | |
| Wool | 1.31 | 1.52 | 0.016 |
| Silk | 1.30 | 3.4 | 0.016 |
| 4.4 with no air voids | | | |
| Man-made Fibers | | | |
| Rayon | 1.52 | 2.03 | 0.031 |
| Acetate | 1.33 | 2.2 | 0.015 |
| Nylon | 1.14 | 2.51 | 0.053 |
| Terylene | 1.38 | 1.97 | 0.030 |
| Teflon | 2.38 | 1.9-2.2 | 0.001-0.003 |
| Fiberglass | 2.34 | 5-7 | 0.001-0.0025 |

3.7.3 Mica and Its Products

Mica is the generic name of a class of crystalline into four main groups:

- (i) muscovite,
- (ii) phlogopite,
- (iii) fibiolite, and
- (iv) lipidolite.

The last two groups are hard and brittle and hence are unsuitable for electrical insulation purposes. Mica can be split into very thin flat laminae. It has got a unique combination of electrical properties, such as high dielectric strength, low dielectric losses, resistance to high temperatures and good mechanical strength. These have made it possible for it to be used in many electrical apparatus. Very pure mica is used for high frequency applications. Spotted mica is used for low voltage insulation, such as for commutator segment separators, armature windings, switchgear and in electrical heating and cooling equipments. Dielectric strength (up to 30°C) varies about 700 – 1000 kV/mm, surface resistivity (60% humidity) 10^{10} - 10^{12} ohm-cm and volume resistivity (constant up to 200°C) 10^{13} - 10^{15} ohm-cm.

Mica is built into sheet form by bonding together with a suitable resin or varnish. Depending on the type of a application, mica can be mixed with the required type of resin to meet the operating temperature requirements. Micanite is another form of mica which is extensively used for insulation purposes. Mica splitting and mica powder are used as fillers in insulating materials, such as glass and phenolic resins. The use of mica as a filler results in improved dielectric strength, reduces dielectric loss and improved heat resistance and hardness of the material.

3.7.4 Glass

Glass is a thermoplastic inorganic material comprising complex systems of oxides (SiO_2). The dielectric constant of glass varies from 3.7 to 10 and the density varies from 2.2 to 6 g/cm³. At room temperature, the volume resistivity of glass varies from 10^{12} to 10^{20} ohm cm. The dielectric loss of glass varies from 0.004 to 0.020 depending on the frequency. The losses are highest at lowest frequencies. The dielectric strength of glass varies from 3000 to 5000 kV/cm and decreases with increases in temperature, reaching half the value at 100°C.

Glass is used as a cover and for internal supports in electric bulbs, electronic valves, mercury arc switches, x-ray equipment, capacitors and as insulators in telephones.

3.7.5 Ceramics

Ceramics are inorganic materials produced by consolidating minerals into monolithic bodies by high temperature heat treatment. Ceramics can be divided into two groups depending on the dielectric constant. Low permittivity ceramics ($\epsilon_r < 12$) are used as insulators, while the high permittivity ceramics ($\epsilon_r > 12$) are used in capacitors and transducers.

Tables 4.5 give the various dielectric properties of some ceramics commonly used for electrical purposes.

Table 3.5 Properties of low permittivity Ceramics

| Property | H.T Porcelain | L.T Porcelain | Low loss steatite | lumina | Forsterite |
|----------|------------------|------------------|----------------------|--------|------------|
| Chemical | 50% clay | 50% clay | 3Mgo, | 95% | 2MgO |

| Composition | 25% Feldspar 25% Flint | 25% Feldspar 25% Flint | 4SiO ₂ H ₂ O | | SiO |
|---|---------------------------|---------------------------|---------------------------------------|------|--------|
| Water Absorption (p.p.m.) Safe | 0 | 0.5 – 2 | 0 | 0 | 0 |
| Temperature (°C) | 1000 | 900 | 1050 | 1600 | 1050 |
| Dielectric Strength (kV/mm) | 25 | 3 | 8 – 25 | 16 | 8 – 12 |
| ϵ_r | 5 – 7 | 5 – 7 | 6 | 9 | 6 |
| $\tan\delta \times 10^4$ | 50-100 | 100-200 | 10 | 5 | 3-4 |

3.7.6 Plastics

Plastics are very widely insulating materials because of their excellent dielectric properties. Many new developments in electrical engineering and electronics would not have been possible without the development of plastics. Plastics are made by combining large numbers of small molecules into a few big ones. When small molecules link to form the bigger molecules of the plastics, many different types of structures result. Most thermoplastic resins approximate to a structure in which several thousand atoms are tied together in one direction. The thermosetting resins on the other hand, form a three-dimensional network. In view of the large number of plastics available, it will not be possible to deal with all of them, and only material which are commonly used for insulation purposes are described.

-Polyethylene is a thermoplastic material which combines unusual electrical properties, high resistance to moisture and chemicals, easy processability, and low cost. They have got dielectric strengths varying from 170 to 1000 kV/cm and volume resistivity greater than 10^{16} ohm-cm.

-Fluorocarbon Plastics are the best plastics used for insulation because of their excellent electrical and mechanical properties. They have got dielectric strengths varying from 104 to 512 kV/cm and volume resistivity greater than 10^{16} ohm-cm.

-Nylon is a thermoplastic which possesses high impact, tensile and flexural strengths over a wide range of temperature (0 to 300°C) with high dielectric strength and good surface and volume resistivities even after lengthy exposure to high humidity, resistant to chemical action, can be easily moulded, extruded and machined. It has got dielectric strength varying from 154 to 204 kV/cm, volume resistivity greater than 10^{12} ohm-cm.

-Polyvinyl chloride or P.V.C. is used in various commercial in various form. It is chemically resistant to strong acids and alkalis and is insoluble in water, alcohol and organic solvents like benzene. The dielectric strength, volume resistivity and surface resistivity are relatively high. The upper temperature limit of operation is about 60°C.

-Polyesters have excellent dielectric properties and superior surface hardness and are highly resistant to most chemicals. Mylor polyester film is being largely used in preference to paper insulation. It has got a dielectric strength of 2000 kV/cm, volume resistivity is better than 10^{15} ohm-cm at 100°C.

-Polystyrene has a dielectric strength comparable to that of mica about 200-350 kV/cm and volume resistivity is about 10^{19} ohm-cm. They are used in the manufacture of low loss capacitors, which will have a very stable capacitance and extremely high insulation resistance.

3.7.7 Rubber

Rubber is a natural or synthetic vulcanizable high polymer having high elastic properties. Electrical properties of rubber depend on the degree of compounding and vulcanizing. General impurities, chemical changes due to ageing, moisture content and variations in temperature and frequency have substantial effects on the electrical properties of rubber. They have got dielectric strengths varying from 80 to 390 kV/cm and temperature from 60°C to 150°C.

3.7.8 Epoxy Resins

They are thermo settings types of insulating materials. They possess excellent dielectric and mechanical properties. The dielectric strength is 75 kV/mm and volume resistivity is about 10^{13} ohm-cm. It can be formed into an insulator of any desired shape for almost any type of high voltage application. It is used for encapsulation of electronic components, generator windings and transformers, for bonding of very divers materials such as porcelain, wood, metals, plastics, etc. It is very important adhesive used for sealing of high vacuum joints.

Module-III

Generation of High Voltages and Currents

In the fields of electrical engineering and applied physics, high voltages (d.c., a.c., and impulse) are required for several applications. For example, electron microscopes and x-ray units require high d.c. voltages of the order of 100 kV or more. Electrostatic precipitators, particle accelerators in nuclear physics, etc. require high voltage (d.c) of several kilovolts and even megavolts. High a.c. voltages of one million volts or even more are required for testing power apparatus rated for extra high transmission voltages (400 kV system and above). High impulse voltages are required for testing purposes to simulate overvoltages that occur in power systems due to lightning or switching surges. For electrical engineers, the main concern of high voltages is for the insulation testing of various components in power systems for different types of voltages, namely, power frequency a.c., high frequency, switching or lightning impulse. Hence, generation of high voltages in laboratories for testing purposes is essential and is discussed in this chapter.

Different forms of high voltages mentioned above are classified as

- (i) high d.c. voltages,
- (ii) high a.c. voltages of power frequency,
- (iii) high a.c. voltages of high frequency,
- (iv) high transient or impulse voltages of very short duration such as lightning overvoltages, and
- (v) transient voltages of longer duration such as switching surges.

Normally, in high voltage testing, the current under conditions of failure is limited to a small value (less than an ampere in the case of d.c. or a.c. voltages and few amperes in the case of impulse or transient voltages). But in certain cases, like the testing of surge diverters or the short circuit testing of switchgear, high current testing with several hundreds of ampere is of importance. Tests on surge diverters require high surge currents of the order of several kiloamperes. Therefore, test facilities require high voltage and

high current generators. High impulse current generation is also required along with voltage generation for testing purposes.

4.1 GENERATION OF HIGH DC VOLTAGE

Generation of high d.c. voltages is mainly required in research work in the areas of pure and applied physics. Sometimes, high direct voltages are needed in insulation tests on cables and capacitors. Impulse generator charging units also require high d.c. voltages of about 100 to 200 kV. Normally, for the generation of d.c. voltages of up to 100 kV, electronic valve rectifiers are used and the output currents are about 100 mA. The rectifier valves require special construction for cathode and filaments since a high electrostatic field of several kV/cm exist between the anode and the cathode in the non-conduction period. The a.c. supply to the rectifier tubes may be of power frequency or may be of audio frequency from an oscillator. The latter is used when a ripple of very small magnitude is required without the use of costly filters to smoothen the ripple.

4.2 Half and Full Wave Rectifier Circuits

Rectifier circuits for producing high d.c. voltages from a.c. sources may be

- (a) halfwave,
- (b) full wave, or
- (c) voltage doubler type rectifiers.

The rectifier may be an electron tube or a solid state device. Nowadays single electron tubes are available for peak inverse voltages up to 250 kV, and semiconductor or solid state diodes up to 20 kV. For higher voltages, several units are to be used in series. When a number of units are used in series, transient voltage distribution along each unit becomes non-uniform and special care should be taken to make the distribution uniform. Commonly used half wave and full wave rectifiers are shown in Fig. 4.1.

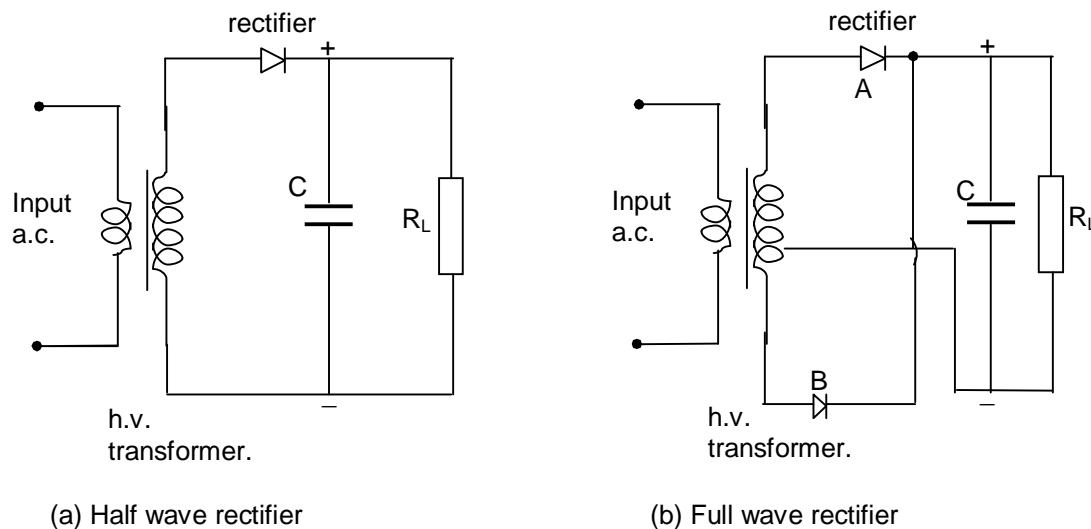

Fig.4.1 Full and Half wave rectifiers

In the half wave rectifier (Fig. 4.1a) the capacitor is charged to V_{max} , the maximum a.c. voltage of the secondary of the high voltage transformer in the conducting half cycle. In

the other half cycle, the capacitor is discharged into the load. The value of the capacitor C is chosen such that the time constant CR_L is at least 10 times that of the period of the a.c. supply. The rectifier valve must have a peak inverse rating of at least $2V_{\max}$. To limit the charging current, an additional resistance R is provided in series with the secondary of the transformer (not shown in the figure).

A full wave rectifier circuit is shown in Fig. 4.1b. In the positive half cycle, the rectifier A conducts and charges the capacitors V_{\max} , while in the negative half cycle the rectifier B conducts and charges the capacitor. The source transformer requires a centre tapped secondary with a rating of $2 V$.

For application at high voltages of 50 kV and above, the rectifier valves used are of special construction. Apart from the filament, the cathode and the anode, they contain a protective shield or grid around the filament and the cathode. The anode will be usually a circular plate. Since the electrostatic field gradient are quite large, the heater and the cathode experience large electrostatic forces during the non-conduction periods. To protect the various elements from these forces, the anode is firmly fixed to the valve cover on one side. On the other side, where the cathode and filament are located, a steel mesh structure or a projective grid kept at the cathode potential surrounds them so that the mechanical forces between the anode and the cathode are reflected on the grid structure only.

Both full wave and half wave rectifiers produce d.c. voltages less than the a.c. maximum voltage. Also, ripple or the voltage fluctuation will be present, and this has to be kept within a reasonable limit by means of filters.

Ripple Voltage With Half Wave and Full Wave Rectifiers

When a full wave or a half wave rectifier is used along with the smoothing condenser C , the voltage on no load will be the maximum a.c. voltage. But when on load, the condenser gets charged from the supply voltage and discharges into load resistance R_L whenever the supply voltage waveform varies from peak value zero value. These waveforms are shown in Fig. 4.2. When loaded, a fluctuation in the output d.c. voltage δV appears, and is called a ripple. The ripple voltage δV is larger for a half wave rectifier than that for a full wave rectifier, since the discharge period in the case of half wave rectifier is larger as shown in Fig. 6.2. The ripple δV depends on (a) the supply voltage frequency f , (b) the time constant CR_L , and (c) the reactance of the supply transformer X_L . For half wave rectifiers, the ripple frequency is equal to the supply frequency and for full wave rectifiers, it is twice that value. The ripple voltage is to

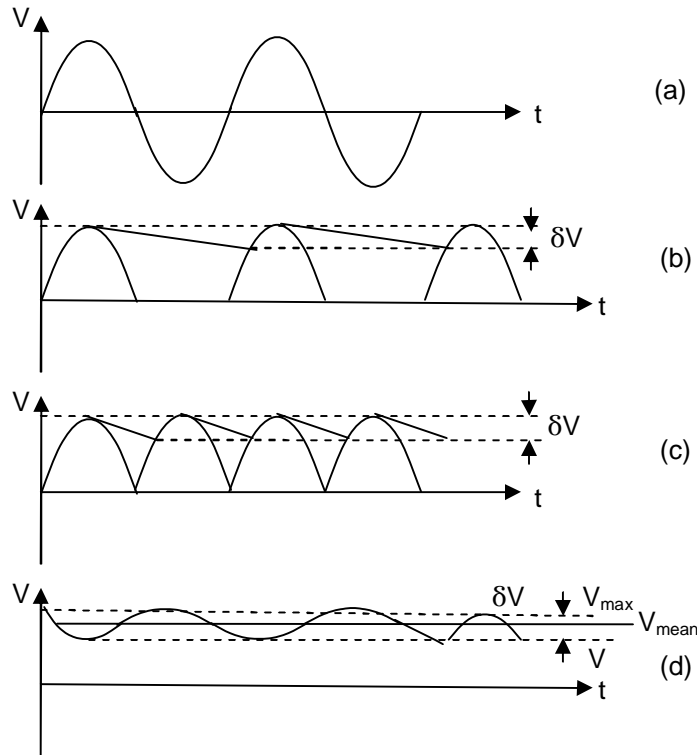

Fig.4.2 Input and output waveforms of half and full wave rectifiers
 (a) Input sine wave, (b) Output with half wave rectifier and condenser filter
 (c) Output with full wave rectifier and condenser filter, (d) V_{\max} , V_{mean} and ripple voltage, δV with condenser filter of a full wave rectifier

be kept as low as possible with the proper choice of the filter condenser and the transformer reactance for a given load R_L .

4.1.2 Voltage Doubler Circuits

Both full wave and half wave rectifier circuits produce a d.c. voltage less than the a.c. maximum voltage. When higher d.c. voltage are needed, a voltage doubler or cascaded rectifier doubler circuits are used. The schematic diagram of voltage doublers are given in Figs. 4.3 a and b.

In voltage doubler circuit shown in Fig. 4.3 a, the condenser C_1 is charged through rectifier R to a voltage of $+V_{\max}$ with polarity as shown in the figure during the negative half cycle. As the voltage of the transformer rises to positive V_{\max} during the next half cycle, the potential of the other terminal of C_1 rises to a voltage of $+2V_{\max}$, depending on the time constant C_2R_L and the forward charging time constant. The ripple voltage of these circuits will be about 2% for $R_L/r \leq 10$ and $X/r \leq 0.25$, where X and r are the reactance and resistance of the input transformer. The rectifiers are rated to a peak inverse voltage of $2V_{\max}$, and the condensers C_1 and C_2 must also have the same rating. If the load current is large, the ripple also is more.

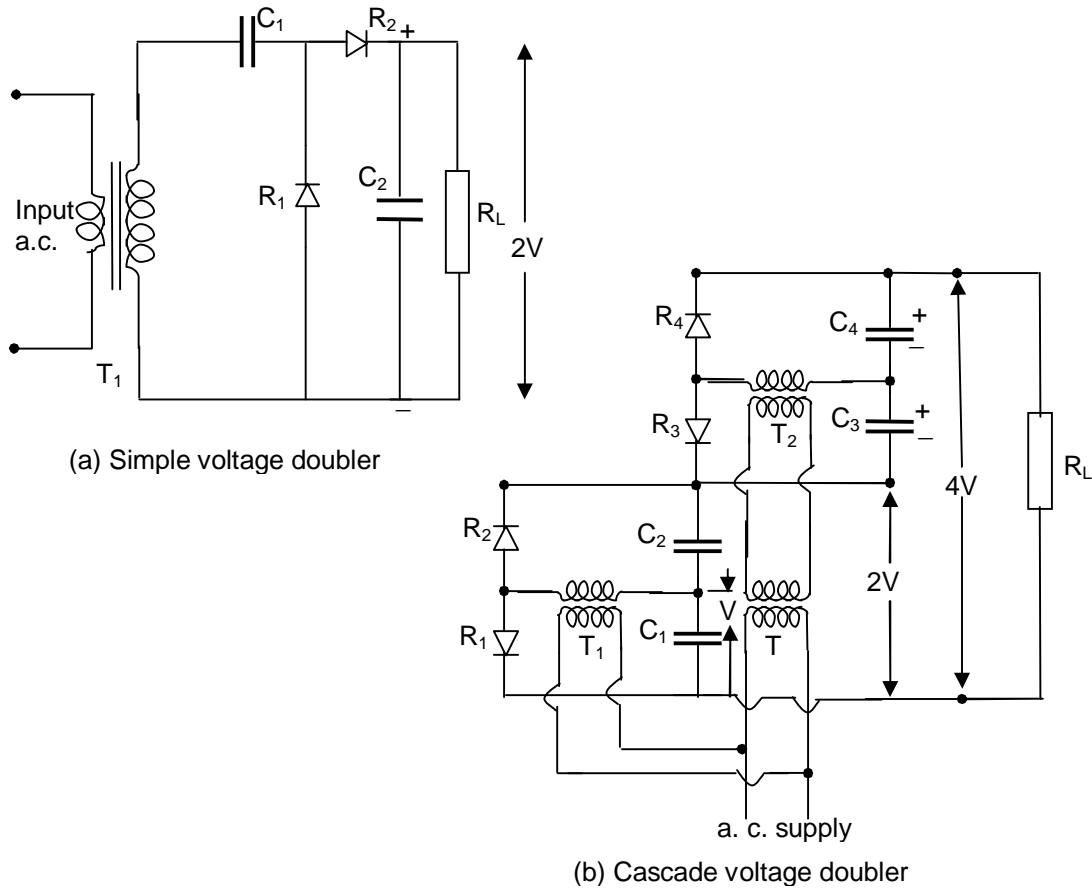

Fig.4.3 Voltage doubler circuits

T_1, T_2 – h. v. transformers; R_1, R_2, R_3, R_4 – rectifiers;

C_1, C_2, C_3, C_4 – condensers; R_L – load resistance; T – isolating transformer

Cascaded voltage doublers are used when larger output voltages are needed without changing the input transformer voltage level. A typical voltage doubler is shown Fig. 4.3b. The rectifiers R_1 and R_2 with transformer T_1 and C_1 and C_2 produce an output voltage of $2V$ in the same way as described above. This circuit is duplicated and connected in series or cascade to obtain a further voltage doubling to $4V$. T is an isolating transformer to give an insulation for $2V_{max}$ since the transformer T_2 is at a potential of $2V_{max}$ above the ground. The voltage distribution along the rectifier string R_1, R_2, R_3 and R_4 is made uniform by having condensers C_1, C_2, C_3 and C_4 of equal values. The arrangement may be extended to give $6V, 8V$, and so on by repeating further stages with suitable isolating transformers. In all the voltage doubler circuits, if valves are used, the filament transformers have to be suitably designed and insulated, as all the cathodes will not be at the same potential from ground. The arrangement becomes cumbersome (large and heavy therefore difficult to carry) if more than $4V$ is needed with cascaded stages.

4.1.3 Voltage Multiplier Circuits

Cascaded voltage multiplier circuits for higher voltages are cumbersome and require too many supply and isolating transformers. It is possible to generate very high d.c. voltages from single supply transformers by extending the simple voltage doubler circuits. This is simple and compact when the load current requirement is less than one milliampere, such as for cathode ray tubes, etc. Valve type pulse generators may be used instead of conventional a.c. supply and the circuit becomes compact. A typical circuit of this form is shown in Fig. 4.4a.

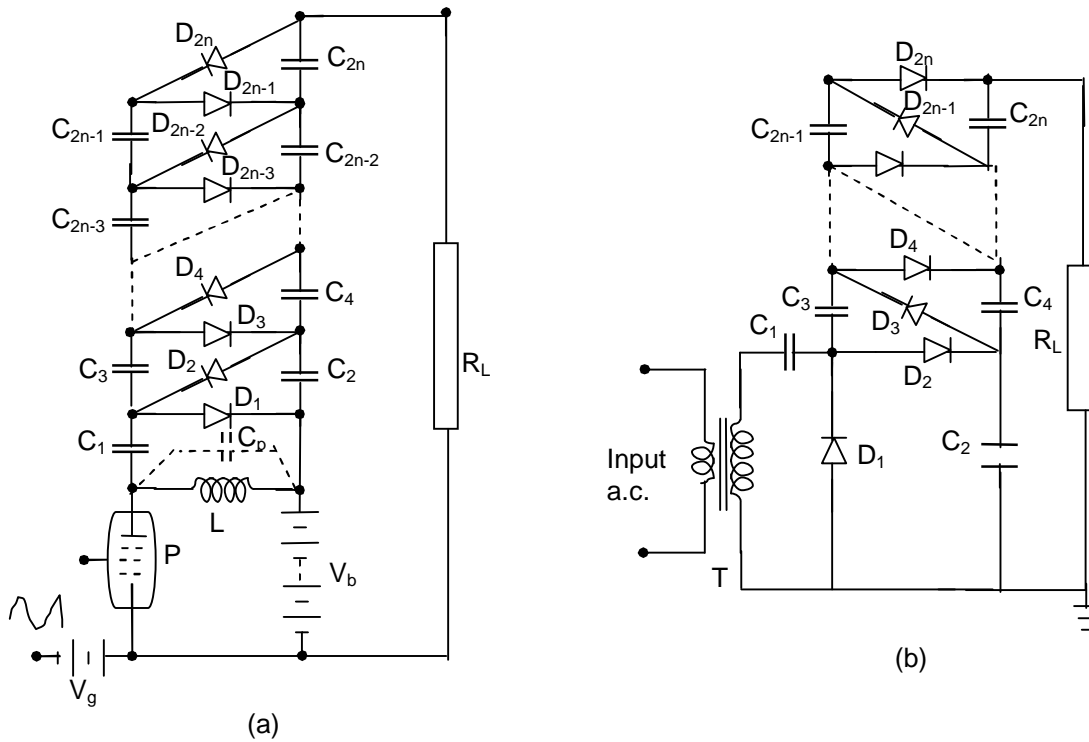

Fig.4.4 (a) Cascade rectifier unit with pulse generator, (b) Cockcroft-Walton voltage multiplier circuit. P – Pulse generator, V_b – D.C. supply to pulse generator, V_g – Bias voltage

The pulses generated in the anode circuit of the valve P are rectified and the voltage is cascaded to give an output of $2nV_{\max}$ across the load R_L . A trigger voltage pulse of triangular waveform (ramp) is given to make the valve switched on and off. Thus, a voltage across the coil L is produced and is equal to $V_{\max} = I_{\max} \sqrt{L/C_p}$, where C_p is the stray capacitance across the coil of inductance L. A d.c. power supply of about 500 V applied to the pulse generator, is sufficient to generate a high voltage d.c. of 50 to 100 kV with suitable number of stages. The pulse frequency is high (about 500 to 1000 Hz) and the ripple is quite low (<1%). The voltage drop on load is about 5% for load currents of about $150 \mu A$. The voltage drops rapidly at high load currents.

Voltage multiplier circuit using the Cockcroft-Walton principle is shown in Fig. 4.4b. The first stage, i.e. D1, D2, C1, C2, and the transformer T are identical, as in the voltage doubler shown in Fig. 4.3a. For higher output voltage of $4, 6, \dots 2n$ of the input voltage V , the circuit is repeated with cascade or series connection. Thus, the condenser C_4 is charged to $4V_{\max}$ and C_{2n} to $2nV_{\max}$ above the earth potential. But voltage across and individual condenser or rectifier is only $2V_{\max}$.

-Ripple in Cascaded Voltages Multiplier Circuits

With load, the output voltage of the cascaded rectifiers is less than $2nV_{\max}$, where n is the number of stages. The ripple and the voltage regulation of the rectifier circuit may be estimated as follows.

Let f = supply frequency,
 q = charge transferred in each cycle,
 I_1 = load current from the rectifier,
 t_1 = conduction period of the rectifiers,
 t_2 = non-conduction period of rectifiers, and
 δV = ripple voltage.

Referring to Fig. 4.3a, when load current I_1 is supplied from condenser C_2 to the load during the non-conduction period t_2 is q , and is related as follows.

$$I_1 = \frac{dq}{dt} \approx \frac{q}{t_2}$$

$$t_1 + t_2 = \frac{1}{f} \text{ (i.e. the period of the a.c. supply voltage),}$$

$$t_2 = \frac{1}{f}$$

Since Also, $q = C_2 \delta V$

$$\text{Hence, } \delta V = \text{the ripple} = \frac{I_1}{f C_2}$$

At the same a charge q is transferred from C_1 to C_2 during each cycle of $x = \frac{I_1}{f C_1}$.

Hence Regulation = mean voltage drop from $2V_{\max}$

$$= \frac{I_1}{f} \left[\frac{1}{C_1} + \frac{1}{2C_2} \right] \quad (6.1)$$

Therefore, the mean output voltage = $2V_{\max} - \frac{I_1}{f} \left(\frac{1}{C_1} + \frac{1}{2C_2} \right)$.

For the cascade circuit, on no load, the voltage between stages is raised by $2nV_{\max}$ for n stages.

Referring to Fig. 4.4b, to find an expression for the total ripple voltage, let it be assumed that all capacitances C_1, C_2, \dots, C_{2n} be equal to C let q be the charge transferred from C_{2n} to the load per cycle. Then the ripple at the condenser C_{2n} will be $\frac{I_1}{fC}$. Simultaneously, C_{2n-2} transfers a charge q to the load and to C_{2n-1} . Hence, the ripple at the condenser C_{2n-2} is $\frac{2I_1}{fC}$. Similarly, C_{2n-4} transfers a charge q to the load, to C_{2n-3} , and to C_{2n-2} . Therefore, the ripple at condenser C_{2n-4} is $\frac{3I_1}{fC}$. Proceeding in the same way, the ripple at C_2 will be $\frac{nI_1}{fC}$. Hence, for n stages the total ripple will be

$$\delta V_{\text{total}} = \frac{I_1}{fC} [1 + 2 + 3 \dots + n] = \frac{I_1}{fC} \frac{n(n+1)}{2} \quad (6.2)$$

It can be seen from the above expression that the lowest capacitances (C_2, C_4 , etc.) contribute most for the ripple. If these capacitances are increased proportionately, i.e. C_1 and C_2 are made equal to nC , C_3 and C_4 are made equal to $(n-1)C$ and so on, the total ripple will be only $\frac{nI_1}{fC}$.

-Regulation or Voltage Drop on Load

In addition to the ripple δV there is a voltage drop ΔV , which is the difference between the theoretical no load and the on load voltage. From the analysis of the ripple voltage, it may be seen that the condenser C_2 is not charged to $2V_{\max}$ but only to $\left(2V_{\max} - \frac{2nI_1}{fC}\right)$.

Similarly, C_4 is charged to only $\left[\left(2V_{\max} - \frac{2nI_1}{fC}\right) - \frac{(2n-1)I_1}{fC}\right]$, as it gives a charge of

$\frac{(2n-1)I_1}{fC}$ during the non-conduction period to the load and to the next condenser. Hence,

the total voltage drop at various condenser stages will be

$$\Delta V_2 = \frac{I_1}{fC} [2n + 2(n-1) + \dots + 2 \cdot 2 + 1]$$

$$\Delta V_4 = \frac{I_1}{fC} [2n + 2(n-1) + \dots + 2]$$

$$\Delta V_{2n-2} = \frac{I_1}{fC} [2n + n - 1]$$

$$\Delta V_{2n} = \frac{I_1}{fC} n$$

Addition of all the n voltage drops gives

$$\begin{aligned} \Delta V &= \frac{I_1}{fC} \left[n + 2n + (n-1) + 2n + 2(n-1) + n - 2 + \dots \right] \\ &= \frac{I_1}{fC} \left[\frac{2}{3}n^3 + \frac{1}{2}n^2 - \frac{1}{6}n \right] \end{aligned} \quad (6.3)$$

Here also, it is seen that most of the voltage drop is due to the lowest stage condensers C_1, C_2 etc. Hence, it is advantageous to increase their values proportional to the number of the stage from the top.

For large values of $n (\geq 5)$, $\frac{n^2}{2}$ and $\frac{n}{6}$ terms in Eq. (4.3) will become small compared to $\frac{2}{3}n^3$ and may be neglected; then the optimum number of stages for the minimum voltage drop may be expressed as

$$n_{\text{optimum}} = \sqrt{\frac{V_{\text{max}} f C}{I}} \quad (6.4)$$

..... I is the load current.

Thus, for a multiplier or a cascaded circuit with $f=50$ Hz, $C=0.1 \mu F$,

$V_{\text{max}} = 100$ kV and $I=5$ mA, the number of stages $n \approx 10$.

The regulation can be improved by increasing f , but an upper limit is set by the high voltage appearing across the inductances and high capacitor current which are considerable. At present, the Cockcroft – Walton type voltage multipliers are available using selenium rectifiers and a.c. supply frequencies of 500 to 1000 Hz for output voltages of more than one million volts and load currents of 30 mA.

Van de Graaff Generator

Preliminary Questions

1. A small sphere of radius r and charge q is enclosed by a spherical shell of radius R and charge Q . Show that if q is positive, charge q will necessarily flow from the sphere to the shell (when the two are connected by a wire) no matter what the charge Q on the shell is. (NCERT PHYSICS).

2. There are three concentric and conducting spheres of radius R , $2R$ and $4R$ respectively. Innermost sphere A and the outermost sphere C are connected by a conducting wire while the intermediate sphere is uniformly charged to $+Q$. Find (a) charges on conductors A and C (b) potential of A and B. (c) If the spheres A and C are earthed,

A machine to make charges was invented in 1931 by a young American called Dr. Robert J. Van de Graaff. Huge machines, some over 30 m high, based on his ideas have been built to produce extremely high voltage (10 MV).

A Van de Graaff generator operates by transferring electric charge from a moving belt to a terminal. The high voltages generated by the Van de Graaff generator can be used for

accelerating subatomic particles to high speeds, making the generator a useful tool for fundamental physics research.

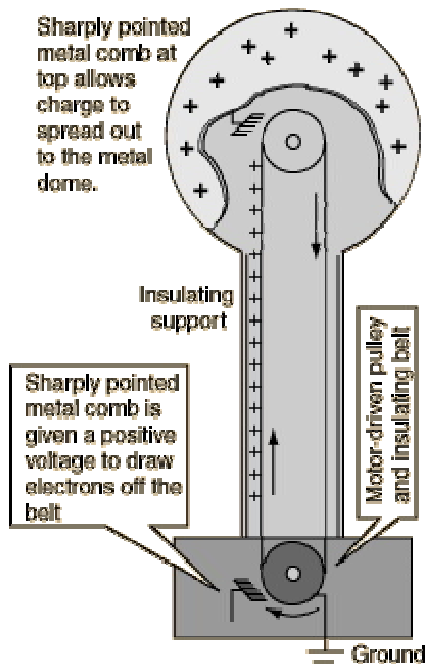

Working of the generator is based on two principles:

- (a) Discharging action of sharp points, i.e., electric discharge takes place in air or gases readily, at pointed conductors.
- (b) If the charged conductor is brought in to internal contact with a hollow conductor, all of its charge transfers to the surface of the hollow conductor no matter how high the potential of the latter may be.

Theory behind construction:

If we have a large conducting spherical shell of radius 'R' on which we place a charge Q, it spreads itself uniformly all over the sphere. The field outside the sphere is just that of a point charge Q at the centre, while the field inside the sphere vanishes. So the potential outside is that of point charge and inside it is constant.

The potential inside the conducting sphere = $\frac{1}{4\pi\epsilon_0} \frac{Q}{R}$

Now suppose that we introduce a small sphere of radius 'r', carrying a charge q, into the large one and place it at the centre. The potential due to this new charge has following values.

Potential due to small sphere of radius r carrying charge $q = \frac{1}{4\pi\epsilon_0} \frac{q}{r}$

Potential at the surface of large shell of radius R = $\frac{1}{4\pi\epsilon_0} \frac{q}{R}$.

Taking both charges q and Q in to account we have for the total potential V and the potential difference given by,

$$V(R) = \frac{1}{4\pi\epsilon_0} \left(\frac{Q}{R} + \frac{q}{R} \right)$$

$$V(r) = \frac{1}{4\pi\epsilon_0} \left(\frac{Q}{R} + \frac{q}{r} \right)$$

$$V(r) - V(R) = \frac{q}{4\pi\epsilon_0} \left(\frac{1}{r} - \frac{1}{R} \right)$$

Now assume that q is positive. We see that, independent of the amount of charge Q that may have accumulated on the larger sphere, it is always at a higher potential: the difference V(r) - V(R) is positive. The potential due to Q is constant upto radius R and so cancels out in the difference.

This means that if we connect the smaller and larger sphere by a wire, the charge q on the former will immediately flow on to the latter, even though the charge Q may be quite large. The natural tendency is for positive charge to move higher to lower potential. Thus, provided we are somehow able to introduce the small charged sphere into the larger one,

we can in this way pile up larger and larger amount of charge on the latter. The potential of the outer sphere would also keep rising, at least until it reaches the breakdown field of air.

Construction:

A simple Van de Graaff-generator consists of an endless belt of silk/rubber/Teflon, or a similar flexible dielectric material, running over two vertically mounted metal pulleys, upper one of which is surrounded by a hollow metal sphere. The belt is run by an electric motor. Two electrodes, in the form of comb-shaped rows of sharp metal points, are positioned respectively near to the bottom of the lower pulley and inside the sphere, over the upper pulley. Upper Comb is connected to the sphere, and lower comb to the ground

The positive terminal of a high tension source (HT) is connected to the lower comb. Charges are accumulated at the pointed ends of the comb, the electric field increases and ionizes the air near them. The positive charges in air are repelled and get deposited on the belt due to corona discharge. The charges are carried by the belt upwards as it moves. When the positively charged portion of the belt comes in front of the upper collecting comb, by the same process of action of points and corona discharge occurs and the metal sphere acquires positive charges. The positive charges are uniformly distributed over the surface of the sphere.

The uncharged portion of the belt returns down collects the positive charge from lower comb which in turn is collected upper comb. The charge transfer process is repeated. As more and more positive charges are imparted to the sphere, its positive potential goes on rising. Leakage of charges in the belt and load puts a limit to generation. If the potential goes beyond this, insulation property of air breaks down and the sphere gets discharged.

Since a Van de Graaff generator can supply the same small current at almost any level of electrical potential, it is an example of a nearly ideal current source. The maximum achievable potential is approximately equal to the sphere's radius multiplied by the e-field where corona discharges begin to form within the surrounding gas.

Can we accelerate negative charges in a Van-de-Graff generator?

Yes, to accelerate electrons, the spherical metallic globe should be at negative potential. For this the polarity of the generator is reversed.

Prob.

Calculate the rate in rise of voltage for such electrostatic generator using SF₆ gas at 10 atmospheric pressure with C= 1000pF, belt width = 3m, belt speed= 200 m/min, charge density= 14×10^{-6} coul/sq. m.

5.1 GENERATION OF HIGH ALTERNATING VOLTAGES

When test voltage requirements are less than about 300kV, a single transformer can be used for test purposes. The impedance of the transformer should be generally less than 5% and must be capable of giving the short circuit current for one minute or more depending on the design. In addition to the normal windings, namely, the low voltage windings, a third windings known as meter windings is provided to measure the output voltage. For higher voltage requirements, a single unit construction becomes difficult and costly due to insulation problems. Moreover, transportation and erection of large transformers become difficult. These drawbacks are by series connection or cascading of the several identical units of transformers, where in the high voltage windings of all the units effectively come in series.

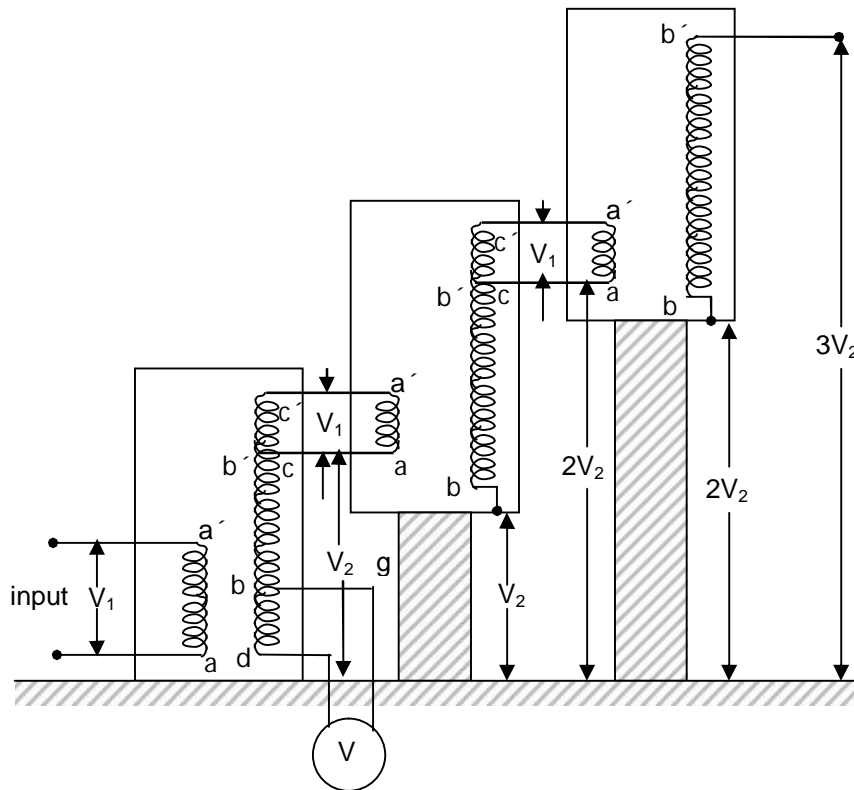

Fig.5.1 Cascade transformer connection (schematic)

V_1 – Input voltage; V_2 – output voltage; aa' - L.V. primary winding; bb' - H.V. secondary winding; cc' - Excitation winding; bd – Meter winding (200 to 500); g – Insulation (pillars or post insulators); V - Voltmeter

5.1.1 Cascade Transformers

Figure 5.1 shows the cascade transformer units in which the first transformer is at the ground potential along with its tank. The second transformer is kept on insulators and maintained at a potential of V_2 , the output voltage of the first unit above the ground. The high voltage winding of the first unit is connected to the tank of the second unit. The low

voltage winding of this unit is supplied from the excitation winding of the first transformer, which is in series with the high voltage winding of the first transformer at its high voltage end. The rating of the excitation windings is almost identical to that of the primary or the low or the low voltage winding. The high voltage connection from the first transformer winding and the excitation winding terminal are taken through a bushing to the second transformer. In a similar manner, the third transformer is kept on insulators above the ground at a potential of $2V_2$ and is supplied likewise from the second transformer. The number of stages in this type of arrangement are usually two four, but very often, three stages are adapted to facilitate a three-phase operation so that $\sqrt{3}V_2$ can be obtained between the lines.

Supply to the units can be obtained from a motor-generator set or through an induction regulstor for variation of the output voltage. The rating of the primary or the low voltage windings is usually 230 or 400 V for small units up to 100 kVA. For larger outputs the rating of the low voltage winding may be 3.3 kV, 6.6kV or 11 kV.

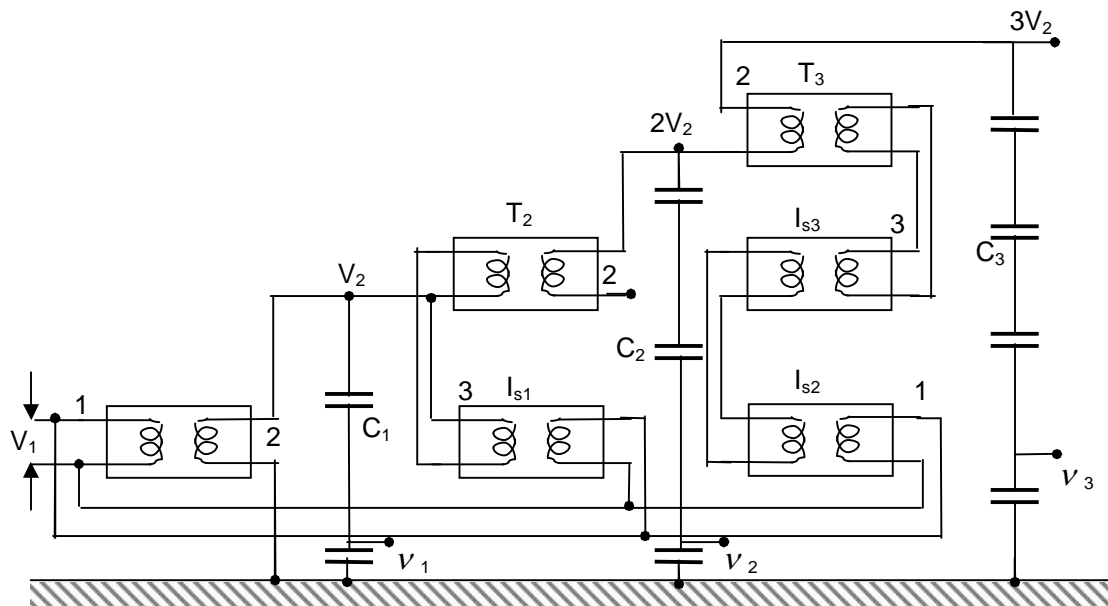

Fig. 5.2 Cascade transformer unit with isolating transformer for excitation

T_1, T_2, T_3 – Cascade transformer units

I_{s1}, I_{s2}, I_{s3} – Isolation transformer units

C_1, C_2, C_3 – Capacitance voltage dividers for h.v. measurement after 1st, 2nd and 3rd stages

V_1, V_2, V_3 - For metering after 1st, 2nd and 3rd stages

1. Primary (l.v. winding), 2. h.v. winding, 3. excitation winding.

In figure Fig. 5.2, a second scheme for providing the excitation to the second and the third stages is shown. Isolating transformers I_{s1}, I_{s2} and I_{s3} are 1:1 ratio transformers and are meant for supplying the excitation for the second and the third stages at their tank

potentials. Power supply to the isolating transformers is also fed from the same a.c. input. This scheme is expensive and requires more space. The advantage of this scheme is that the natural cooling is sufficient and the transformers are light and compact. Transportation and assembly is easy. Also the construction is identical for isolating transformers and the high voltage cascade units. Three phase connection in delta or star is possible for three units. Testing transformers of ratings up to 10 MVA are cascade connection to give high voltages up to 2.25 MV are available for both indoor and outdoor applications.

In order to reduce the size and cost of the insulation, sometimes transformers with a centre tap on high voltage windings earthed or connected to the tank are used. This connection results in a cheaper construction, and the high voltage insulation now needs to be designed for $V_2/2$, that of second transformer at $3V_2/2$, and that of the third transformer at $5V_2/2$.

All the cascade transformer units which are meant for the supply of excitation to the next stage have large leakage between the primary (or the low voltage winding) and the excitation windings. Hence, they are invariably provided with compensating windings.

5.1.2 Resonant Transformers

The equivalent circuit of a high voltage testing transformer consist of the leakage reactances of the windings, the windings resistances, the magnetizing reactance, and the shunt capacitance across the output terminal due to the bushing of the high voltage terminal and also that of the test object. This is shown in Fig.5.3.

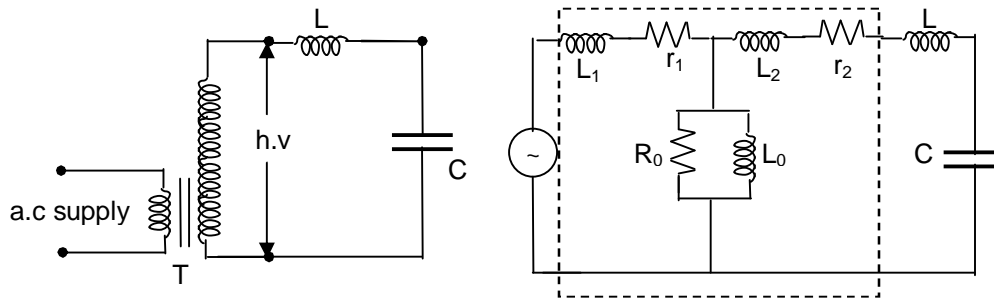

Fig.5.3 Resonant transformer and equivalent circuit. T – Testing transformer;
 L – choke; C – Capacitance of a h.v. terminal and test object;
 L_0 – Magnetizing inductance; L_1, L_2 – Leakage inductance of the transformer; r_1, r_2 – resistance of the windings; R_0 – Resistance due to core loss

It may be seen that it is possible to have series resonance at power frequency $\omega, (L_1 + L_2) = 1/\omega C$. With this condition, the current in the tests object is very large and is limited only by the resistance of the circuit. The waveform of the voltage across the

test object will be purely sinusoidal. The magnitude of the voltage across the capacitance C of the test object will be

$$V_c = \left| \frac{-jVX_c}{R+j(X_L-X_c)} \right| = \frac{V}{R} X_c = \frac{V}{\omega CR} \quad (6.8)$$

where R is the total series resistances of the circuit.

The factor X_c/R is the Q factor of the circuit and gives the magnitude of the voltage multiplication across the test object under resonance conditions. Therefore, the input voltage required for excitation is reduced by a factor $1/Q$, and the output kVA required is also reduced by a factor $1/Q$. the secondary power factor of the circuit is unity.

This principle is utilized in testing at very high voltage and on occasions requiring large current outputs such as cable testing, dielectric loss measurements, partial discharge measurements, etc. a transformer with 50 to 100 kV voltage rating and a relatively large current rating is connected together with an additional choke, if necessary. The test condition is set such that $\omega(L_c + L) = 1/\omega C$ where L_c is the total equivalent leakage inductance of the transformer including its regulating transformer. The chief advantages of this principle are:

- a) it gives an output of pure sine wave,
- b) power requirements are less (5 to 10% of total kVA required),
- c) no high power arcing and heavy current surges occur if the test object failed, as resonance ceases at the failure of the test object,
- d) cascading is also possible for very high voltage,
- e) simple and compact test arrangement, and
- f) no repeated flashovers occur in case of partial failures of the test object and insulation recovery. It can be shown that the supply source takes Q number of cycles at least to charge the test specimen to the full voltage.

The disadvantages are the requirements of additional variable chokes capable of withstanding the full test voltage and the full current rating.

5.2.3 Generation of High Frequency a.c. High Voltages

High frequency high voltage are required for rectifier d.c. power supplies as discussed. Also, for testing electrical apparatus for switching surges, high frequency high voltage damped oscillators are needed which need high voltage high frequency transformers.

The advantages of these high frequency transformers are:

- i) the absence of iron core in transformers and hence saving in cost and size,
- ii) pure sine wave output,
- iii) slow build-up of voltage over a cycles and hence no damage due to switching surges, and
- iv) uniform distribution of voltage across the winding coils due to subdivision of coil stack into a number of units.

The commonly used high frequency resonant transformer is the Tesla coil, which is a doubly tuned resonant circuit shown schematically in Fig. 5.4a.

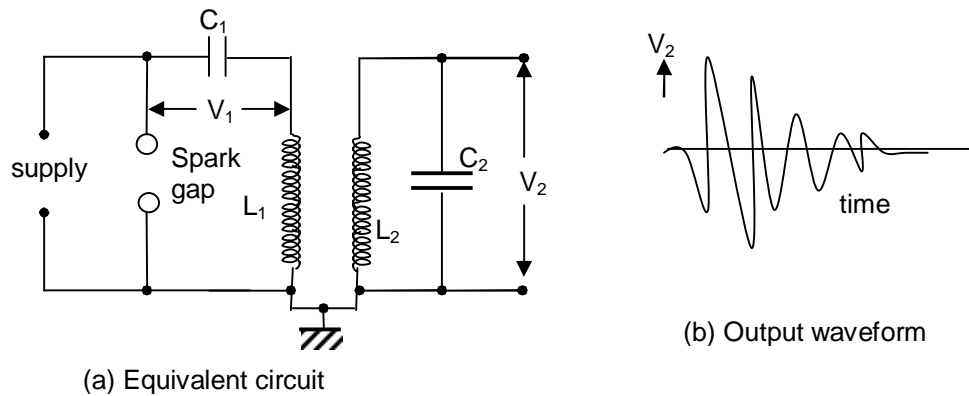

Fig.5.4 Tesla coil equivalent circuit and its output waveform

The primary voltage rating is 10 kV and the secondary may be rated to as high as 500 to 1000 kV. The primary is fed from a d.c. or a.c. supply through the condenser C_1 . A spark gap G connected across the primary is triggered at the desired voltage V_1 which induces a high self excitation in the secondary. The primary and the secondary windings (L_1 and L_2) are wound on an insulated former with no core (air cored) and are immersed in oil. The windings are tuned to a frequency of 10 to 100kHz by means of the condensers C_1 and C_2 . The output voltage V_2 is a function of the parameters L_1 , L_2 , C_1 , C_2 , and the mutual inductances M . usually, the windings resistance will be small and contribute only for damping of the oscillations.

The analysis of the output waveform can be done in a simple manner neglecting the winding resistance. Let the condenser C_1 be charged to a voltage V_1 when the spark gap is triggered. Let a current i_1 flow through the primary windings L_1 and produce a current i_2 through L_2 and C_2 .

Then,

$$V_1 = \frac{1}{C_1} \int_0^t dt + L_1 \frac{di_1}{dt} + M \frac{di_2}{dt} \quad (6.9)$$

$$\text{and, } 0 = \frac{1}{C_2} \int_0^t dt + L_2 \frac{di_2}{dt} + M \frac{di_1}{dt}$$

The Laplace transformed equations for the above are,

$$\frac{V_1}{s} = \left[L_1 s + \frac{1}{C_1 s} \right] I_1 + M s I_2 \quad (6.10)$$

$$\text{and, } 0 = [M s] I_1 + \left[L_2 s + \frac{1}{C_2 s} \right] I_2$$

where I_1 and I_2 are the Laplace transformed values of i_1 and i_2 . The output voltage V_2 across the condenser C_2 is

$V_2 = \frac{1}{C_2} \int_0^t i_2 dt$; or its transformed equation is

$$V_2(s) = \frac{I_2}{C_2 s} \quad (6.11)$$

where, $V_2(s)$ is the Laplace transform of V_2 .

The solution for V_2 from the above equations will be

$$V_2 = \frac{MV_1}{\sigma L_1 L_2 C_1} \frac{1}{\gamma_2^2 - \gamma_1^2} [\cos \gamma_1 t - \cos \gamma_2 t] \quad (6.12)$$

where,

$$\sigma^2 = \frac{M^2}{L_1 L_2} = 1 - K^2$$

K = coefficient of coupling between the windings L_1 and L_2

$$\gamma_{1,2} = \frac{\omega_1^2 + \omega_2^2}{2} \mp \sqrt{\left(\frac{\omega_1^2 + \omega_2^2}{2}\right)^2 - \omega_1^2 \omega_2^2 (1 - K^2)}$$

$$\omega_1 = \frac{1}{\sqrt{L_1 C_1}} \text{ and } \omega_2 = \frac{1}{\sqrt{L_2 C_2}}$$

The output waveform is shown in Fig. 6.13b.

The peak amplitude of the secondary voltage V_2 can be expressed as,

$$V_{2 \max} = V_{1e} \sqrt{\frac{L_2}{L_1}} \quad (6.13)$$

$$e = \frac{2\sqrt{1-\sigma}}{\sqrt{(1+a)^2 - 4\sigma a}}$$

where,

$$a = \frac{L_2 C_2}{L_1 C_1} = \frac{\omega_1^2}{\omega_2^2}$$

A more simplified analysis for the Tesla coil may be presented by considering that the energy stored in the primary circuit in the capacitance C_1 is transferred to C_2 via the magnetic coupling. If W_1 is the energy stored in C_1 and W_2 is the energy transferred to C_2 and if efficiency of the transformer is η , then

$$W_1 = \frac{1}{2} C_1 V_1^2 = \eta \left(\frac{1}{2} C_2 V_2^2 \right) \quad (6.14)$$

$$\text{from which } V_2 = \eta \sqrt{\frac{C_1}{C_2}} \quad (6.14a)$$

It can be shown that if the coefficient of coupling K is large oscillation frequency is less, and for large values of the winding resistance and K , the waveform may become a

unidirectional impulse. This is shown in the next sections while dealing with the generation of switching surges.

6.GENERATION OF IMPULSE VOLTAGES

6.0 Standard Impulse Wave-shapes

Transient over voltages due to lightning and switching surges cause steep build-up of voltage on transmission lines and other electrical apparatus. Experimental investigations showed that these waves have rise time of 0.5 to 10 μ s and decay time to 50% of peak value of the order of 30 to 200 μ s. The wave-shapes are arbitrary, but mostly unidirectional. It is shown that lightning over-voltage wave can be represented as double exponential waves defined by the equation

$$V=V_0[\exp(-\alpha t)-\exp(-\beta t)] \quad (6.15)$$

where α and β are constants of microsecond values.

The above equation represents a unidirectional wave which usually has a rapid rise to the peak value and slowly falls zero value.

The general wave-shape is given in Fig. 6.14. Impulse wave are specified by defining their rise or front time, fall or tail time to 50% peak value, and the value of the peak voltage. Thus 1.2/50 μ s, 1000 kV wave represents an impulse voltage wave with a front time of 1.2 μ s, fall time to 50% peak value of 50 μ s, and a peak value of 1000 kV. When impulse wave-shapes are recorded, the initial portion of the wave will not be clearly defined or sometimes will be missing. Moreover, due to disturbances it may contain superimposed oscillations in the rising portion. Hence, the front and tail times have to be defined.

Referring to the wave-shape in Fig. 6.14, the peak value A is fixed and referred to as 100% value. The points corresponding to 10% and 90% of the peak values are located in the front portion (points C and D).

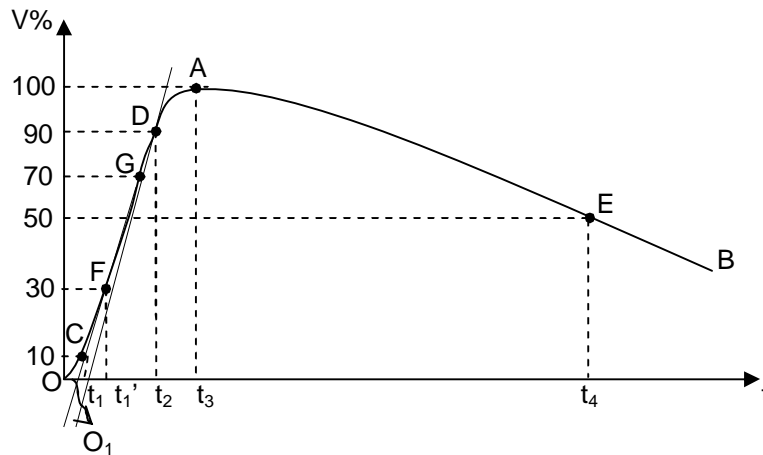

Fig.6.1 Impulse waveform and its definitions

The line joining these points is extended to cut the time axis at O_1 . O_1 is taken as the virtual origin. 1.25 times the interval between times t_1 and t_2 corresponding to points C and D (projections on the time axis) is defined as the front time, i.e. 1.25

$(O_1t_2 - O_1t_1)$. The point E is located on the wave tail corresponding to 50% of the peak value, and its projection on the time axis t_4 . O_1t_4 is defined as the fall or tail time. In case the point C is not clear or missing from the wave-shape record, the point corresponding to 30% peak value F is taken and its projection t_1 is located on time axis. The wave front time in that case will be defined as $1.67 (O_1t_3 - O_1t'_1)$. The tolerances that can be allowed in the front and tail times are respectively $\pm 30\%$ and $\pm 20\%$. Indian standard specifications define $1.2/50 \mu s$ wave as standard impulses. Considering the tolerances allowed, all the above wave-shapes overlap and give rise to a wave-shape which lies within the specified limits. The tolerance allowed in the peak value is $\pm 3\%$.

The impulse waves are generally represented by the Eq. (6.15) given earlier. V_0 in the equation represents a factor that depends on the peak value. For impulse wave of $1.2/50 \mu s$, $a=0.0146$, $\beta = -2.467$, and $V_0 = 1.04$ when time t is expressed in microseconds.

α and β control the front and tail time of the wave respectively.

A double exponential waveform of the type mentioned in Eq. (6.15) may be produced in the laboratory with a combination of a series R-L-C circuit under overdamped condition or by the combination of two R-C circuits. Different equivalent circuits that produce impulse waves are given in Figs. 6.15 a to e. Out of these circuits, the ones shown in Figs. 6.2a to d are commonly used. Circuit shown in Fig. 6.15a is limited to model generators only, and commercial generators employ circuits shown in Figs. 6.2b to 6.2d.

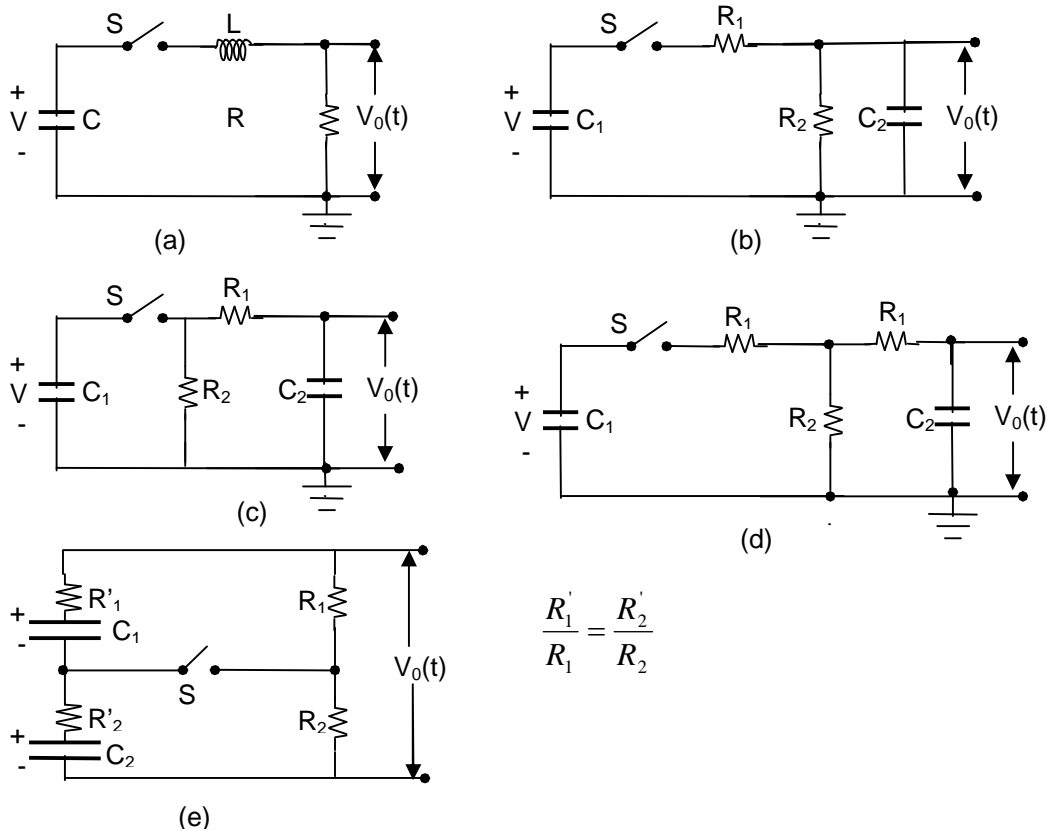

Fig.6.2 Circuits for producing impulse waves

A capacitor C_1 or C previously charged to a particular d.c. voltage is suddenly discharged into the wave-shaping network (LR, R_1, R_2, C_2 or other combination) by closing the switch S . The discharge voltage $V_0(t)$ shown in Fig. 6.2 gives rise to the desired double exponential wave-shape.

Analysis of Impulse Generator Circuit Series
R-L-C Type

Referring to Fig. 6.15 the current through the load resistance R is given by

$$V = \frac{1}{C} \int_0^t i dt + Ri + L \frac{di}{dt} \quad (6.16)$$

with initial condition at $t=0$ being $i(0)=0$ and the net charge in the circuit $i=dq/dt=0$. Writing the above equation as a Laplace transformer equation,

$$V/s = \left(\frac{1}{C_s} + R + L_s \right) I(s)$$

or,
$$I(s) = \frac{V}{L} \left[\frac{1}{s^2 + \frac{R_s}{L} + \frac{1}{LC}} \right]$$

The voltage across the resistor R (Which is the output) is,

$$v_0(s) = I(s)R, \text{ hence,}$$

$$v_0(s) = V \frac{R}{L} \frac{1}{s^2 + \frac{R_s}{L} + \frac{1}{LC}}$$

For an overdamped condition, $R/2L \geq 1/\sqrt{LC}$

Hence, the roots of the equation $s^2 + \frac{R_s}{L} + \frac{1}{LC}$ are $\alpha = s_1 = -\frac{R}{2L} + \sqrt{\left(\frac{R}{2L}\right)^2 - \frac{1}{LC}}$,

$$\beta = s_2 = -\frac{R}{2L} - \sqrt{\left(\frac{R}{2L}\right)^2 - \frac{1}{LC}}$$

The solution of the equation for $v_0(t)$ is,
$$v_0(t) = \frac{V \left(\frac{R}{2L} \right)}{\left[\frac{R^2}{4L^2} - \frac{1}{LC} \right]^{\frac{1}{2}}} \left[e^{-\alpha t} - e^{-\beta t} \right] =$$

$$V_0 \left[e^{-\alpha t} - e^{-\beta t} \right]$$

The sum of the roots $\left(\alpha + \beta = -\frac{R}{2L} \right)$ and the product of the roots are $\alpha\beta = -\frac{1}{LC}$

The wave front and the wave tail times are controlled by changing the values of R and L simultaneously with a given generator capacitance C; choosing a suitable value for L. β or the wave front time is determined and α or the wave tail time is controlled by the value of R in the circuit. The advantage of this circuit is its simplicity. But the waveshape control is not flexible and independent. Another disadvantage is that the basic circuit is altered when a test object which will be mainly capacitive in nature, is connected across the output. Hence, the waveshape gets changed with the change of test object.

Analysis of the Other Impulse Circuits

The most commonly used configurations for impulse generators are the circuits shown in Fig. 6.2b and c. The advantages of these circuits are that the wave front and wave tail times are independently controlled by changing either R_1 or R_2 separately. Secondly, the test object which are mainly capacitive in nature from part of C_2 .

For the configuration shown in Fig. 6.2 b, the output voltage across C_2 is given by,

$v_0(t) = \frac{1}{C_2} \int_0^t i_2 dt$. Performing Laplace transformation, $\frac{1}{C_2 s} I_2(s) = v_0(s)$ where I_2 is the current through C_2 . Taking the current through C_1 as I_1 and its transformed value as $I_1(s)$,

$$I_2(s) = \left(\frac{R_2}{R_2 + \frac{1}{C_2 s}} \right) I_1(s) \text{ and } I_1(s) = \frac{V}{s} \frac{1}{C_1 s + R_1 + \frac{1}{R_2 + \frac{1}{C_2 s}}}$$

Substitution of $I_1(s)$ gives $v_0(s)$ and simplifying and taking inverse transform of $v_0(t) = \frac{V}{R_1 C_2 (\alpha - \beta)} [\exp(-\alpha t) - \exp(-\beta t)]$ (6.20)

Usually, $\frac{1}{C_1 R_1}$ will be much smaller compared to $\frac{1}{R_1 C_1}$.

Hence, the roots may be approximated as

$$\alpha \approx \frac{1}{R_1 C_2} \text{ and } \beta = \frac{1}{R_2 C_1} \quad (6.21)$$

Following a similar analysis, it may be shown that the output waveform for the circuit

$$v_0(t) = \frac{V C R_2 \alpha \beta}{(\beta - \alpha)} [\exp(-\alpha t) - \exp(-\beta t)]$$

configuration of Fig. 6.2c will be

where α and β are the roots of the Eq. (6.19). The approximate values of α and β given by Eq. (6.21) are valid for this circuit also. The equivalent circuit given in Fig. 6.2d is a

combination of the configurations of Fig. 6.15b and 6.15c. The resistance R_1 is made into two parts and kept on either side R_2 to give greater flexibility for the circuits. The configuration of Fig. 6.15e is not commonly used. It is useful only for testing high inductance test objects such as transformers.

Restrictions on the Ratio of the Generator and Load Capacitance, C_1/C_2 on the Circuit Performance

For a given waveshape, the choice of R_1 and R_2 to control the wave front and wave tail times is not entirely independent but depends on the ratio of C_1/C_2 . It can be shown mathematically that $R_2 = P(y)/C_1$ and $R_1 = Q(y)/C_1$ where $y = C_1 C_2$ and P and Q are functions of y . In order to get real values for R_1 and R_2 for a given waveshape, a maximum and minimum value of y exists in practice. This is true whether the configuration of Fig. 6.2b or 6.2c is used. For example, with the circuit of Fig. 6.15b, the ratio of C_1/C_2 cannot exceed 3.35 for a $1/5 \mu s$ waveshape. Similarly, for a $1/50 \mu s$ waveshape the ratio C_1/C_2 lies between 106.5. If the configuration chosen is 6.15c, the minimum value of C_1/C_2 for $1/5 \mu s$ waveshape is about 0.01. The reader is referred to High Voltage Laboratory Techniques by Craggs and Meek for further discussion on the restrictions imposed on the ratio C_1/C_2 .

Effect of Circuit Inductances and Series Resistance on the Impulse Generator Circuits

The equivalent circuits shown in Fig. 6.2 a to e, in practice several stray series inductances. Further, the circuits occupy considerable space and will be spread over several meters in testing laboratory. Each component has some residual inductances and the circuit loop itself contributes for further inductance. The actual value of the inductance may vary from $10 \mu H$ to several hundreds of microhenries. The effect of the inductance is to cause oscillations in the wave front and in the wave tail portions. Sometimes, in order to control the front time a small inductance is added.

Waveshape Control

Generally, for a given impulse generator of Fig. 6.2b or c the generator capacitance C_1 and load capacitance C_2 will be fixed depending on the design of the generator and the test object. Hence, the desired waveshape is obtained by controlling R_1 and R_2 . The following approximate analysis is used to calculate the wave front and wave tail times. The resistance R_2 will be large. Taking the circuit inductance to be negligible during charging, C_1 charges the load capacitance C_2 through R_1 . Then the time taken for charging is approximately three times the time constant of the circuit and is given by

$$t_1 = 3.0 R_1 \frac{C_1 C_2}{C_1 + C_2} = 3 R_1 C_e \quad (6.22) \text{ where } C_e = \frac{C_1 C_2}{C_1 + C_2}. \quad \text{If } R_1 \text{ is}$$

given in ohms and C_e in microfarads, t_1 is obtained in microseconds.

For discharging or tail time, the capacitance C_1 and C_2 may be considered to be in parallel and discharging occurs R_1 and R_2 . Hence, the time for 50% discharge is approximately given by $t_2 = 0.7(R_1 + R_2)(C_1 + C_2)$ (6.23)

These formulae for t_1 and t_2 hold good for the equivalent circuits are shown in Fig. 6.2b and c. For the circuit given in Fig. 6.2d, R is to be taken as $2 R_1$. With the approximate formulae, the wave front and wave tail times can be estimated to within $\pm 20\%$ for the standard impulse waves.

6.4 GENERATION OF IMPULSE CURRENTS

Lightning discharges involve both high voltage impulses and high current impulses on transmission lines. Protective gear like surge diverters have to discharge the lightning currents without damage. Therefore, generation of impulse current waveforms of high magnitude ($\approx 100\text{kA}$ peak) find application in testing work as well as in basic research on non-linear resistors, electric arc studies, and studies relating to electric plasmas in high current discharges.

6.4.1 Definition of Impulse Current Waveforms

The waveshape used in testing surge diverters are 4/10 and 8/20 μs , the figures respectively representing the nominal wave front and wave tail times (see Fig. 6.14). The tolerances allowed on these times are $\pm 10\%$ only. Apart from the standard impulse current, waves, rectangular waves of long duration are also used for testing. The waveshape should be nominally rectangular in shape. The rectangular waves generally have durations of the order of 5.0 ms, with rise and fall times of the order of 0.5 to 5.0 ms, with rise and fall times of the waves being less than $\pm 10\%$ of their total duration. The tolerance allowed on the peak value is $+20\%$ and -0% (the peak value may be more than the specified value but not less). The duration of the wave is at least defined as the total time of the wave during which the current is at least 10% of its peak value.

6.4.2 Circuits for Producing Impulse Current Waves

For producing impulse currents of large value, a bank of capacitors connected in parallel are charged to a specified value and are discharged through a series R-L circuit as shown in Fig. 6.20.

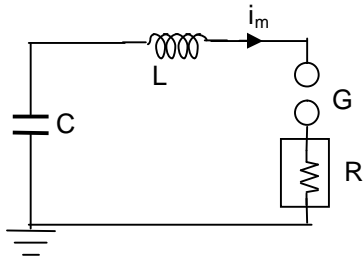

(a) Basic circuit of an impulse current generator

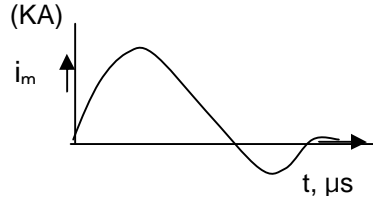

(b) Impulse current waveform

Fig. 6.3 Impulse current generator circuit and its waveform

C represents a bank of capacitors connected in parallel which are charged from a d.c. source to a voltage up to 200 kV. R represents the dynamic resistance of the rest object and the resistance of the circuit and the shunt. L is an air cored high current inductor, usually a spiral tube of a few turns.

If the capacitor is charged to a voltage V and discharged when the spark gap is triggered, the current i_m will be given by the equation

$$V = Ri_m + L \frac{di_m}{dt} + \frac{1}{C} \int_0^t i_m dt \quad (6.24)$$

The circuit is usually under damped, so that $\frac{R}{2} < \sqrt{\frac{L}{C}}$. Hence i_m is given by,

$$i_m = \frac{V}{\omega L} e^{-\alpha t} \sin(\omega t) \text{ where } \alpha = \frac{R}{2L} \text{ and } \omega = \sqrt{\frac{1}{LC} - \frac{R^2}{4L^2}}$$

The time taken for the current i_m to rise from zero to the first peak value is

$$t_1 = t_f = \frac{1}{\omega} \sin^{-1} \frac{\omega}{\sqrt{LC}} \quad (6.26)$$

The duration for one half cycle of the damped oscillatory wave t_2 is,

$$t_2 = \frac{\pi}{\sqrt{\frac{1}{LC} - \frac{R^2}{4L^2}}} \quad (6.27)$$

It can be shown that the maximum value of i_m normally independent of the value of V C

for a given energy $W = \frac{1}{2} CV^2$, and the effective inductance L. it is also clear from Eq.

(6.25) that a low inductance is needed in order to get high current magnitudes for a given charging voltage V.

For an 8/20 μs standard impulse current wave $a = 0.0535 \times 10^6$ and $\omega = 0.113 \times 10^6$ when R,L and C are expressed in ohms, microhenries, and microfarads respectively. The product of LC=65. Hence, knowing the value of the generator capacitance, L can be

calculated as $L=65/C$, and R can be obtained from Eq. (6.25a) as $R=2 L_a$. The peak value of $i_m = I_p$ is given by $(VC)/14$ when V is kV. I_p in kilo-amperes, and C in microfarads.

6.4.3 Generation of High Impulse Currents

For producing large values of impulse currents, a number of capacitors are charged in parallel and discharge in parallel into the circuit. In order to minimize the effective inductance, the capacitors are subdivided into smaller units.

If there are n_1 groups of capacitors, each consisting of n_2 units and if L_0 is the inductance of the common discharge path, L_1 is that of each group and L_2 is that of each unit, then

the effective inductance L is given by
$$L = L_0 + \frac{L_1}{n} + \frac{L_2}{n_1 n_2}$$

Also, the arrangement of capacitors into a horse-shoe layout minimizes the effective load inductance.

The essential parts of an impulse current generator are:

- (i) a.d.c charging unit giving a variable voltage to the capacitor bank,
- (ii) capacitors of high value (0.5 to 5 μF) each with very low self inductance, capable of giving high short circuit currents,
- (iii) an additional air cored inductor of high current value,
- (iv) proper shunts and oscillograph for measurement purposes, and
- (v) a triggering unit and spark gap for the initiation of the current generator.

Questions

- 6.1 Explain with diagrams, different types of rectifier circuits for producing high d.c. voltages.
- 6.2 Why is a Cockcroft-Walton circuit preferred for voltage multiplier circuits? Explain its working with a schematic diagram.
- 6.3 Give the expression for ripple and regulation in voltage multiplier circuits. How are the ripple and regulation minimized?
- 6.4 Explain the different schemes of cascade connection of transformers for producing very high a.c. voltages,
- 6.5 Why is it preferable to use isolating transformers for excitation with cascade transformer units, if the power requirement is large?
- 6.6 What is the principle of operation of a resonant transformer? How is it advantageous over the cascade connected transformers?
- 6.7 What is a Tesla coil? How are damped high frequency oscillations obtained from a Tesla coil?
- 6.8 Define the front and tail times of an impulse wave. What are the tolerances allowed as per the specifications?
- 6.9 Give different circuits that produce impulse wave explaining clearly their relative merits and demerits.
- 6.10 Describe the circuit arrangement for producing lightning current wave-forms in laboratories.
- 6.11 How is the circuit inductance controlled and minimized in impulse current generators?

Prob. An impulse generator has eight stages with each condenser rated for $0.16\mu\text{FD}$ and 125 kV. The load capacitor available is 1000 pFD. Find the series resistance and damping resistance needed to produce standard lightning impulse. If the charging voltage is 120 kV, what is the maximum output voltage and discharge energy?

7.Measurement of High Voltages and Currents

The devices and instruments for measurement of high voltages and currents differ vastly from the low voltage and low current devices.

7.1 MEASUREMENT OF HIGH DIRECT CURRENT VOLTAGES

High voltages can be measured in a variety of ways. Direct measurement of high voltages is possible up to about 200 kV, and several forms of voltmeters have been devised which can be connected directly across the test circuit. High Voltages are also measured by stepping down the voltage by using transformers and potential dividers. The sparkover of sphere gaps and other gaps are also used, especially in the calibration of meters in high voltage measurements. Transient voltages may be recorded through potential dividers and oscilloscopes.

Lightning surges may be recorded using the Klydonograph.

Direct Measurement of High Voltages

7.1.1 Electrostatic Voltmeters

Principle is used in electrostatic voltmeter?

If the electric field is produced by the voltage V between a pair of parallel plate disc electrodes, the force F on an area A of the electrode, for which the field gradient E is the same across the area and perpendicular to the surface.

One of the direct methods of measuring high voltages is by means of electro-static voltmeters. For voltages above 10 kV, generally the attracted disc type of electrostatic voltmeter is used.

When two parallel conducting plates (cross section area A and spacing x) are charged q and have a potential difference V , then the energy stored in the is given by

Energy stored $W = \frac{1}{2} C V^2$ so that change $dW = \frac{1}{2} V^2 dC = F dx$

Force $F = \frac{1}{2} V^2 (dC/dx)$ Newton $= \frac{1}{2} A \epsilon (V^2/x^2)$.

It is thus seen that the force of attraction is proportional to the square of the potential difference applied, so that the meter reads the square value (or can be marked to read the rms value).

Electrostatic voltmeters of the attracted disc type may be connected across the high voltage circuit directly to measure up to about 200 kV, without the use of any potential divider or other reduction method. [The force in these electrostatic instruments can be used to measure both a.c. and d.c. voltages].

7.1.2 Sphere gaps

The sphere gap method of measuring high voltage is the most reliable and is used as the standard for calibration purposes. The breakdown strength of a gas depends on the ionisation of the gas molecules, and on the density of the gas. As such, the breakdown voltage varies with the gap spacing; and for a uniform field gap, a high consistency could be obtained, so that the sphere gap is very useful as a measuring device. By precise experiments, the breakdown voltage variation with gap spacing, for different diameters and distances, have been calculated and represented in charts. In the measuring device, two metal spheres are used, separated by a gas-gap. The potential difference between the spheres is raised until a spark passes between them. The breakdown strength of a gas depends on the size of the spheres, their distance apart and a number of other factors. A spark gap may be used for the determination of the peak value of a voltage wave, and

for the checking and calibrating of voltmeters and other voltage measuring devices. The density of the gas (generally air) affects the spark-over voltage for a given gap setting. Thus the correction for any air density change must be made. The air density correction factor $\delta = 0.386P/(273+t)$

The spark over voltage for a given gap setting under the standard conditions (760 torr pressure and at 20°C) must be multiplied by the correction factor to obtain the actual spark-over voltage. The breakdown voltage of the sphere gap (figure 6.2) is almost independent of humidity of the atmosphere, but the presence of dew on the surface lowers the breakdown voltage and hence invalidates the calibrations.

The breakdown voltage characteristic (figure 6.3) has been determined for similar pairs of spheres (diameters 62.5 mm, 125 mm, 250 mm, 500 mm, 1 m and 2 m)

When the gap distance is increased, the uniform field between the spheres becomes distorted, and accuracy falls.

The limits of accuracy are dependant on the ratio of the spacing **d** to the sphere diameter **D**, as follows. $d < 0.5 D$, accuracy = $\pm 3 \%$; $0.75 D > d > 0.5 D$, accuracy = $\pm 5 \%$

For accurate measurement purposes, gap distances in excess of 0.75D are not used.

The breakdown voltage characteristic is also dependant on the polarity of the high voltage sphere in the case of asymmetrical gaps (i.e. gaps where one electrode is at high voltage and the other at a low voltage or earth potential). If both electrodes are at equal high voltage of opposite polarity (i.e. $+ \frac{1}{2} V$ and $- \frac{1}{2} V$), as in a symmetrical gap, then the polarity has no effect. Figure 6.4 shows these breakdown voltage variations. In the case of the asymmetrical gap, there are two breakdown characteristics; one for the positive high voltage and the other for the negative high voltage. Since the breakdown is caused by the flow of electrons, when the high voltage electrode is positive, a higher voltage is generally necessary for breakdown than when the high voltage electrode is negative. However, when the gaps are very far apart, then the positive and the negative characteristics cross over due to various space charge effects. But this occurs well beyond the useful operating region. Under alternating voltage conditions, breakdown will occur corresponding to the lower curve (i.e. in the negative half cycle under normal gap spacings). Thus under normal conditions, the a.c. characteristic is the same as the negative characteristic.

In sphere gaps used in measurement, to obtain high accuracy, the minimum clearance to be maintained between the spheres and the neighbouring bodies and the diameter of shafts are also specified, since these also affect the accuracy (figure 6.5). There is also a tolerance specified for the radius of curvature of the spheres. "The length of any diameter shall not differ from the correct value by more than 1% for spheres of diameter up to 100 cm or more than 2% for larger spheres". Peak values of voltages may be measured from 2 kV up to about 2500 kV by means of spheres. One sphere may be earthed with the other being the high voltage electrode, or both may be supplied with equal positive and negative voltages with respect to earth (symmetrical gap).

When spark gaps are to be calibrated using a standard sphere gap, the two gaps should not be connected in parallel. Equivalent spacing should be determined by comparing each gap in turn with a suitable indicating instrument.

Needle gaps may also be used in the measurement of voltages up to about 50 kV, but errors are caused by the variation of the sharpness of the needle gaps, and by the corona forming at the points before the gap actually sparks over. Also the effect of the variation of the humidity of the atmosphere on such gaps is much greater.

Usually, a resistance is used in series with the sphere gap, of about 1ohm/V sparkover conditions to about a maximum of 1 A.

However for impulse measurements, a series resistance must not be used since this causes a large drop across the resistance. In measuring impulse voltages, since the breakdown does not occur at exactly the same value of voltage each time, what is generally specified is the 50 % breakdown value. A number of impulses of the same value is applied and a record is kept of the number of times breakdown occurs, and a histogram is plotted with the peak value of the impulse voltage and the percentage of breakdown (figure 6.6).

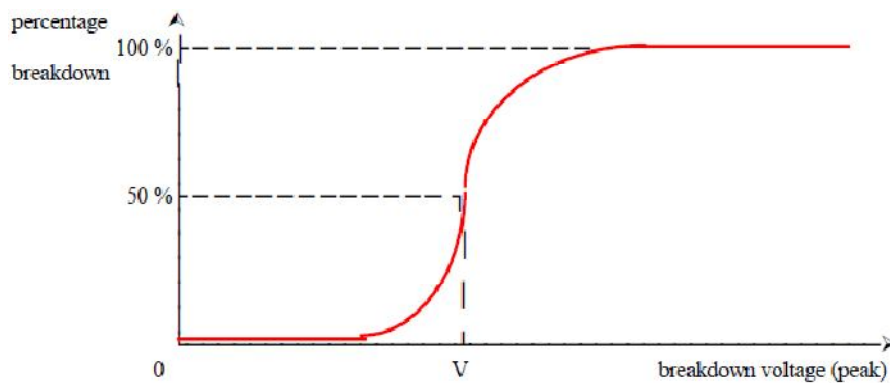
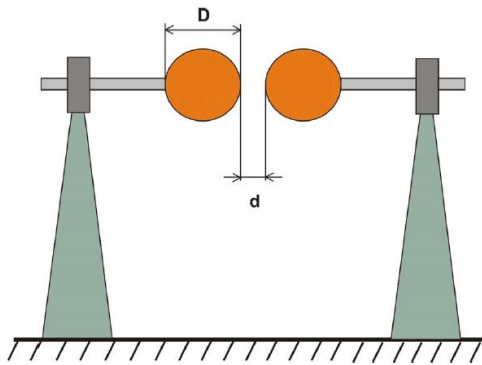

The factors that are influencing the peak voltage measurement using sphere gap are
 (i) Nearby earthed objects (ii) Atmosphere conditions (iii) Influence of humidity
 (iii) Irradiation (iv) Polarity and rise time of voltage waveform (v) Switching surge

7.1.3 GENERATING VOLTMETER (GVM)

A generating voltmeter is a variable capacitor voltage generator which generates current proportional to the voltage to be measured. It provides loss free measurement of D.C and A.C voltages. It is driven by a synchronous motor and does not absorb power or energy from the voltage measuring source.

Whenever the source loading is not permitted or when direct connection to the high voltage source is to be avoided, the generating principle is employed for the measurement of high voltages, A generating voltmeter is a variable capacitor electrostatic voltage generator which generates current proportional to the voltage to be measured. Similar to electrostatic voltmeter the generating voltmeter provides loss free measurement of d.c. and a.c. voltages. The device is driven by an external constant speed motor and does not absorb power or energy from the voltage measuring source. The principle of operation is explained with the help of Fig. 4.8. H is a high voltage electrode and the earthed electrode is subdivided into a sensing or pick up electrode P , a guard electrode G and a movable electrode M , all of which are at the same potential. The high voltage electrode H

develops an electric field between itself and the electrodes P , G and M . The field lines are shown in Fig. 7.1. The electric field density ϵ is also shown. If electrode M is fixed and the voltage V is changed, the field density ϵ would change and thus a current $i(t)$ would flow between P and the ground.

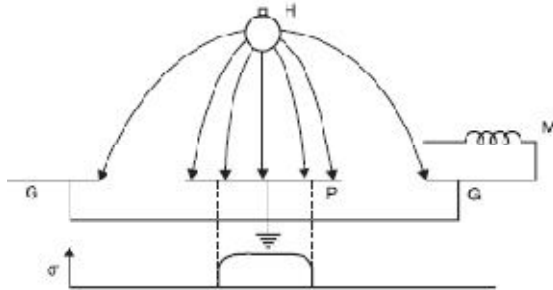

Fig.7.1 Principle of generating voltmeter

The high voltage electrode and the grounded electrode in fact constitute a capacitance system. The capacitance is, however, a function of time as the area A varies with time and, therefore, the charge $q(t)$ is given as $q(t)=C(t)V(t)$

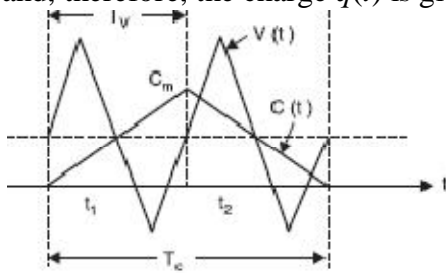

Fig. 7.2 Capacitance and voltage variation

Differentiating with respect to t gives $i(t)=dq/dt= V(dC/dt)$ for DC voltage application.

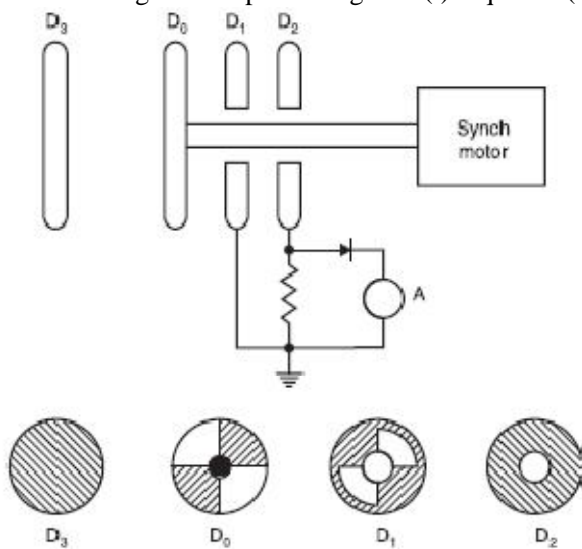

Fig.7.3 schematic diagram of a generating voltmeter

GVM shown in Fig.7.3 which employs rotating vanes for variation of capacitance. The high voltage electrode is connected to a disc electrode D_3 which is kept at a fixed distance on the axis of the other

low voltage electrodes D_2 , D_1 , and D_0 . The rotor D_0 is driven at a constant speed by a synchronous motor at a suitable speed. The rotor vanes of D_0 cause periodic change in capacitance between the insulated disc D_2 and the high voltage electrode D_3 . The number and shape of vanes are so designed that a suitable variation of capacitance (sinusoidal or linear) is achieved. The a.c. current is rectified and is measured using moving coil meters. If the current is small an amplifier may be used before the current is measured.

Advantages of generating Voltmeter: (i) Scale is linear and extension of voltage range is easy (ii) Source loading is zero (iii) It can measure wide range of voltages (iv) There is no connection to H.V. electrode.

Disadvantage: (i) need calibration (ii) Careful construction is needed (iii) Disturbance in position and mounting of the electrodes make the calibration invalid.

7.2 THE CHUBB-FORTESCUE METHOD (for peak Ac HV measurement)

Simple and accurate method for the peak measurement of a.c. voltages.

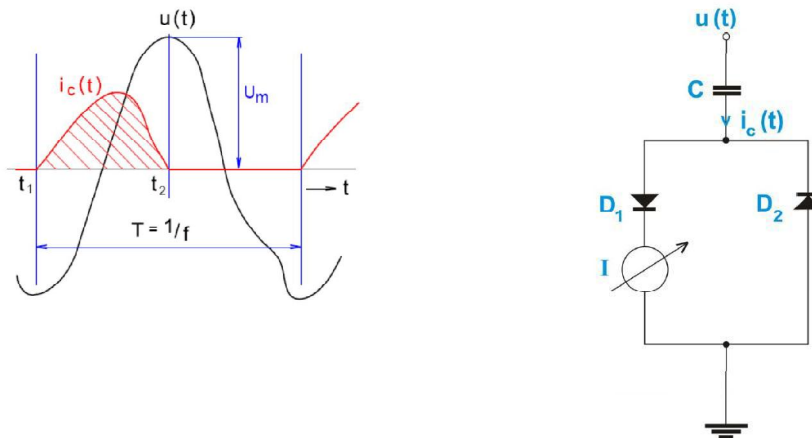

Current through capacitor C:

$$i_C = C \frac{du}{dt}$$

Mean value of measured current:

$$I = \frac{1}{T} \int_{t_1}^{t_2} i_C dt = \frac{C}{T} [u(t_2) - u(t_1)] = \frac{C}{T} U_{pp}$$

Peak value of measured voltage:

$$U_m = \frac{I}{2Cf}$$

7.3 Voltage dividers

Voltage dividers for a.c., d.c. or impulse voltages may consist of resistors or capacitors or a convenient combination of these elements. Inductors are normally not used as voltage dividing elements as pure inductances of proper magnitudes without stray capacitance cannot be built and also these inductances would otherwise form oscillatory circuit with the inherent capacitance of the test object and this may lead to inaccuracy in measurement and high voltages in the measuring circuit. The height of a voltage divider depends upon the flash over voltage and this follows from the rated maximum voltage applied.

Now, the potential distribution may not be uniform and hence the height also depends upon the design of the high voltage electrode, the top electrode. For voltages in the megavolt range, the height of the divider becomes large. As a thumb rule following clearances between top electrode and ground may be assumed.

2.5 to 3 metres/MV for d.c. voltages.

2 to 2.5 m/MV for lightning impulse voltages.

More than 5 m/MV rms for a.c. voltages.

More than 4 m/MV for switching impulse voltage.

The divider dimensions are related to maximal applied voltage. The potential divider is most simply represented by two impedances Z_1 and Z_2 connected in series and the sample voltage required for measurement is taken from across Z_2 ,

Divider ratio:

$$\frac{U_2}{U_1} = \frac{Z_2}{Z_1 + Z_2}$$

Resistive divider $\frac{U_2}{U_1} = \frac{R_2}{R_1 + R_2}$

Capacitive divider $\frac{U_2}{U_1} = \frac{C_1}{C_1 + C_2}$

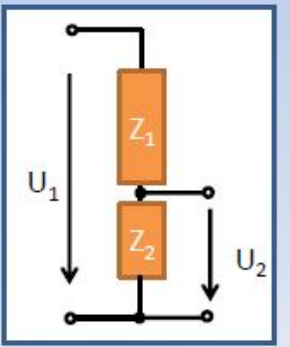

The voltage V_2 is normally only a few hundred volts and hence the value of Z_2 is so chosen that V_2 across it gives sufficient deflection on a CRO. Therefore, most of the voltage drop is available across the impedance Z_1 and since the voltage to be measured is in megavolt the length of Z_1 is large which result in inaccurate measurements because of the stray capacitances associated with long length voltage dividers (especially with impulse voltage measurements) unless special precautions are taken. On the low voltage side of the potential dividers where a screened cable of finite length has to be employed for connection to the oscillograph other errors and distortion of wave shape can also occur.

7.4 Resistive Dividers

The resistance potential dividers are the first to appear because of their simplicity of construction, less space requirements, less weight and easy portability. These can be placed near the test object which might not always be confined to one location.

The length of the divider depends upon two or three factors. The maximum voltage to be measured is the first and if height is a limitation, the length can be based on a surface flash over gradient in the order of 3–4 kV/cm irrespective of whether the resistance R_1 is of liquid or wirewound construction. The length also depends upon the resistance value but this is implicitly bound up with the stray capacitance of the resistance column, the product of the two (RC) giving a time constant the value of which must not exceed the duration of the wave front it is required to record.

It is to be noted with caution that the resistance of the potential divider should be matched to the equivalent resistance of a given generator to obtain a given wave shape.

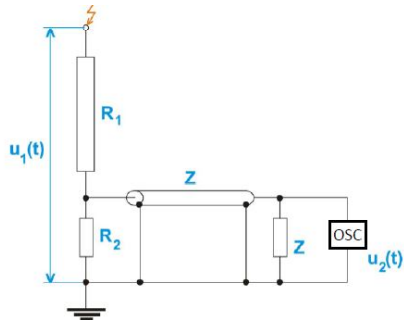

Capacitive Dividers

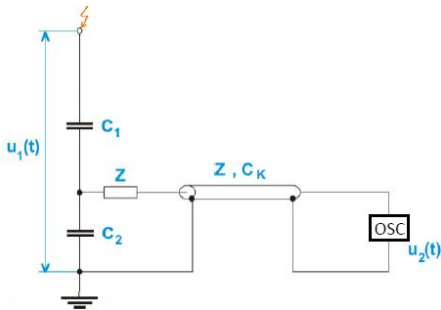

Capacitance potential dividers are more complex than the resistance type. For measurement of impulse voltages not exceeding 1 MV capacitance dividers can be both portable and transportable. In general, for measurement of 1 MV and over, the capacitance divider is a laboratory fixture. The capacitance dividers are usually made of capacitor units mounted one above the other and bolted together. It is this failure which makes the small dividers portable. A screening box similar to that described earlier can be used for housing both the low voltage capacitor unit C_2 and the matching resistor if required. The low voltage capacitor C_2 should be non-inductive. A form of capacitor which has given excellent results is of mica and tin foil plate, construction, each foil having connecting tags coming out at opposite corners. This ensures that the current cannot pass from the high voltage circuit to the delay cable without actually going through the foil electrodes. It is also important that the coupling between the high and low voltage arms of the divider be purely capacitive. Hence, the low voltage arm should contain one capacitor only; two or more capacitors in parallel must be avoided because of appreciable inductance that would thus be introduced. Further, the tappings to the delay cable must be taken off as close as possible to the terminals of C_2 .

7.5 RC Voltage Divider

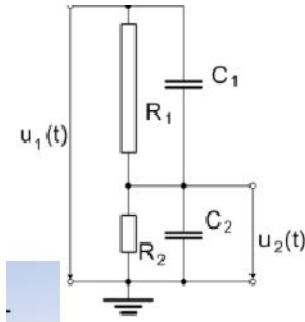

$$Z_1 = \frac{R_1}{1 + j\omega C_1 R_1} \quad Z_2 = \frac{R_2}{1 + j\omega C_2 R_2}$$

$$\frac{U_2}{U_1} = \frac{\omega C_1 R_1 - jR_2}{\omega R_1 R_2 (C_1 + C_2) - j(R_1 + R_2)}$$

$$\operatorname{Im} \left(\frac{U_2}{U_1} \right) = \frac{\omega R_1 R_2 (C_1 R_1 - C_2 R_2)}{(R_1 + R_2)^2 + \omega^2 R_1^2 R_2^2 (C_1 + C_2)^2} = 0$$

$$\Rightarrow C_1 R_1 = C_2 R_2$$

7.6 MEASUREMENT OF HIGH D.C., AND IMPULSE CURRENTS

High currents are used in power system for testing circuit breakers, cables lightning arresters etc. and high currents are encountered during lightning discharges, switching transients and shunt faults. These currents require special techniques for their measurements.

7.6.1 High Direct Currents

Low resistance shunts are used for measurement of these currents. The voltage drop across the shunt resistance is measured with the help of a milli-voltmeter. The value of the resistance varies usually between 10 microhm and 13 milliohm. This depends upon the heating effect and the loading permitted in the circuit. The voltage drop is limited to a few millivolts usually less than 1 V. These resistances are oil immersed and are made as three or four terminal resistances to provide separate terminals for voltage measurement for better accuracy.

7.6.2 Hall Generators

Hall effect is used to measure very high direct current. Whenever electric current flows through a metal plate placed in a magnetic field perpendicular to it, Lorentz force will deflect the electrons in the metal structure in a direction perpendicular to the direction of both the magnetic field and the flow of current. The charge displacement results in an e.m.f. in the perpendicular direction called the Hall voltage. The Hall voltage is proportional to the current I , the magnetic flux density B and inversely proportional to the plate thickness d i.e., $V_H = RBI/d$

where R is the Hall coefficient which depends upon the material of the plate and temperature of the plate. For metals the Hall coefficient is very small and hence semiconductor materials are used for which the Hall coefficient is high.

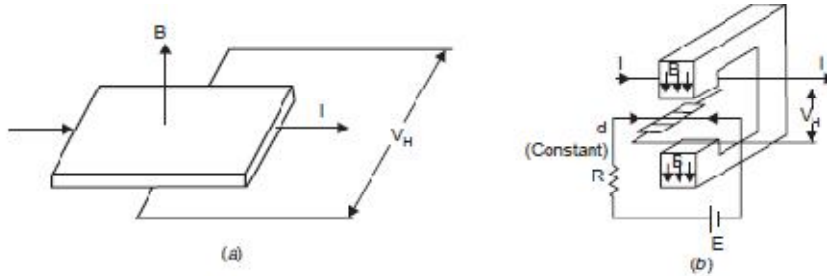

Fig. Hall generator
140 HIGH VOLTAGE ENGINEERING

When large d.c. currents are to be measured the current carrying conductor is passed through an iron cored magnetic circuit (Fig. (b)). The magnetic field intensity produced by the conductor in the air gap at a depth d is given by $H = I/(2\pi d)$

The Hall element is placed in the air gap and a small constant d.c. current is passed through the element. The voltage developed across the Hall element is measured and by using the expression for Hall voltage the flux density B is calculated and hence the value of current I is obtained.

7.6.3 High Power Frequency Currents

High Power frequency currents are normally measured using current transformers as use of low resistance shunts involves unnecessary power loss. Besides, the current transformers provide isolation from high voltage circuits and thus it is safer to work on *HV* circuits Fig. below shows a scheme for current measurements using current transformers and electro-optical technique.

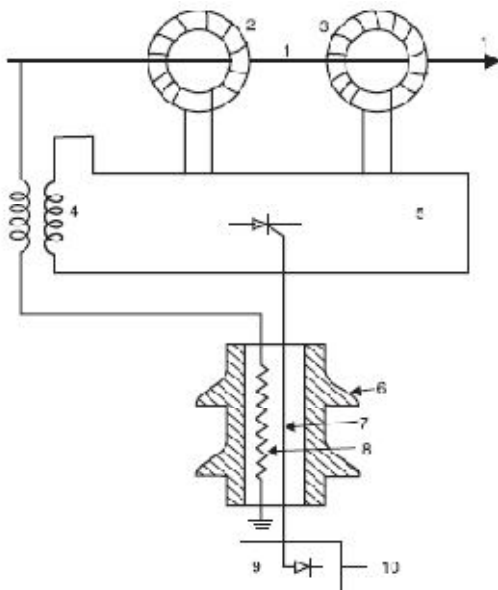
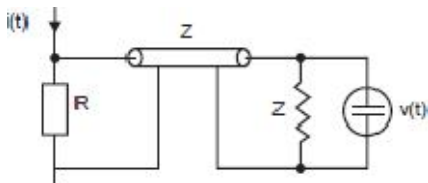

Fig. Current transformers and electro-optical system for high a.c. current measurements
A voltage signal proportional to the current to be measured is produced and is transmitted to the ground through the electro-optical device. Light pulses proportional to the voltage signal are transmitted by a glass optical fibre bundle to a photodetector and converted

back into an analog voltage signal. The required power for the signal convertor and optical device are obtained from suitable current and voltage transformers.

7.6.4 High Frequency and Impulse Currents

In power system the amplitude of currents may vary between a few amperes to a few hundred kiloamperes and the rate of rise of currents can be as high as 10^{10} A/sec and the rise time can vary between a few micro seconds to a few macro seconds. Therefore, the device to be used for measuring such currents should be capable of having a good frequency response over a very wide frequency band. The methods normally employed are—(i) resistive shunts; (ii) elements using induction effects; (iii) Faraday and Hall effect devices. With these methods the accuracy of measurement varies between 1 to 10%. Fig. shows the circuit diagram of the most commonly used method for high impulse current measurement. The voltage across the shunt resistance R due to impulse current $i(t)$ is fed to the oscilloscope through a delay cable D . The delay cable is terminated through an impedance Z equal to the surge impedance of the cable to avoid reflection of the voltage to be measured and thus true measurement of the voltage is obtained. Since the dimension of the resistive element is large, it will have residual inductance L and stray capacitance C . The inductance could be neglected at low frequencies but at higher frequencies the inductive reactance would be comparable with the resistance of the shunt. The effect of inductance and capacitance above 1 MHz usually should be considered. The resistance values range between 10 micro ohm to a few milliohms and the voltage drop is of the order of few volts. The resistive shunts used for measurements of impulse currents of large duration is achieved only at considerable expense for thermal reasons. The resistive shunts for impulse current of short duration can be built with rise time of a few nano seconds of magnitude. The resistance element can be made of parallel carbon film resistors or low inductance wire resistors of parallel resistance wires or resistance foils.



Assuming the stray capacitance to be negligibly small the voltage drop across the shunt in complex frequency domain may be written as $V(s) = I(s)[R + Ls]$

It is to be noted that in order to have flat frequency response of the resistive element the stray inductance and capacitance associated with the element must be made as small as possible. In order to minimise the stray field effects following designs of the resistive elements have been suggested and used

1. Bifilar flat strip shunt.
2. Co-axial tube or Park's shunt
3. Co-axial squirrel cage shunt.

The bifilar flat strip shunts suffer from stray inductance associated with the resistance element and its potential leads are linked to a small part of the magnetic flux generated by the current that is being measured. In order to eliminate the problems associated with the bifilar shunts, coaxial shunts were developed. Here the current enters the inner cylinder of the shunt element and returns through an outer cylinder. The space between the two

cylinders is occupied by air which acts like a perfect insulator. The voltage drop across the element is measured between the potential pick up point and the outer case. The frequency response of this element is almost a flat characteristic upto about 1000 MHz and the response time is a few nanoseconds. The upper frequency limit is governed by the skin effect in the sensitive element.

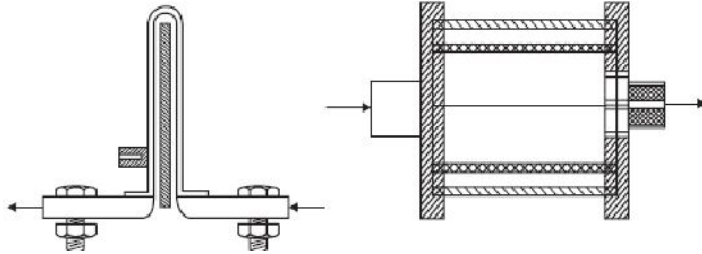

Fig. (i) Bifilar flat strip; (ii) Co-axial squirrel cage

Squirrel cage shunts are high ohmic shunts which can dissipate larger energies as compared to coaxial shunts which are unsuitable due to their limitation of heat dissipation, larger wall thickness and the skin effect. Squirrel cage shunt consists of thick metallic rods or strips placed around the periphery of a cylinder and the structure resembles the rotor construction of a double squirrel cage induction motor. The step response of the element is peaky and, therefore, a compensating network is used in conjunction with the element to improve its frequency response. Rise times less than 8 ns and band width of 400 MHz have been obtained with these shunts.

7.6.5 Elements using Induction Effects (Rogowski coil)

If the current to be measured is flowing through a conductor which is surrounded by a coil as shown in Fig., and M is the mutual inductance between the coil and the conductor, the voltage across the coil terminals will be: $v(t) = M(di/dt)$

Usually the coil is wound on a non-magnetic former in the form of a toroid and has a large number of turns, to have sufficient voltage induced which could be recorded. The coil is wound criss-cross to reduce the leakage inductance. If N is the number of turns of the coil, A the coil area and l_m its mean length, the mutual inductance is given by

$$M = \mu_0 NA / l_m$$

Usually an integrating circuit RC is employed as shown in Fig. to obtain the output voltage proportional to the current to be measured. The output voltage is given by $v_o(t) = Mi(t)/(RC)$

Integration of $v(t)$ can be carried out more elegantly by using an appropriately wired operational amplifier. The frequency response of the Rogowski coil is flat upto 100 MHz but beyond that it is affected by the stray electric and magnetic fields and also by the skin effect.

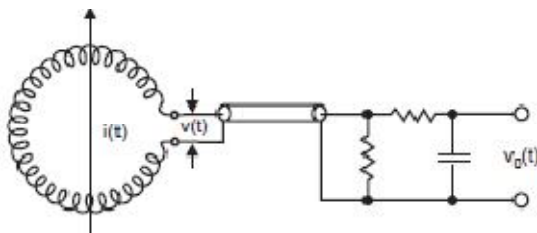

Fig. Rogowski coil for high impulse current measurements

7.6.6 Magnetic Links

These are used for the measurement of peak magnitude of the current flowing in a conductor. These links consist of a small number of short steel strips on high retentivity. The link is mounted at a known distance from the current carrying conductor. It has been found through experiments that the remanant magnetism of the link after impulse current of 0.5/5 micro sec shape passes through the conductor is same as that caused by a direct current of the same peak value. Measurement of the remanance possessed by the link after the impulse current has passed through the conductor enables to calculate the peak value of the current. For accurate measurements, it is usual to mount two or more links at different distances from the same conductor. Because of its relative simplicity, the method has been used for measurement of lightning current especially on transmission towers.

It is to be noted that the magnetic links help in recording the peak value of the impulse current but gives no information regarding the wave shape of the current. For this purpose, an instrument called Fulcronograph has been developed which consists of an aluminium wheel round the rim of which are slots containing magnetic links of sufficient length to project on both sides of the wheel. As the wheel is rotated, the links pass successively through a pair of narrow coils through which flows the current to be measured. The current at the instant during which a particular link traverses the coil, can be determined by a subsequent measurement of the residual flux in the link and, therefore, a curve relating the variation of current with time can be obtained. The time scale is governed by the speed of rotation of the wheel.

Hall Generators

The high amplitude a.c. and impulse currents can be measured by Hall Generator described earlier. For the Hall Generator, though a constant control current flows which is permeated by the magnetic field of the current to be measured, the Hall voltage is directly proportional to the measuring current. This method became popular with the development of semi-conductor with sufficient high value of Hall constant. The band width of such devices is found to be about 50 MHz with suitable compensating devices and feedback.

Possible End Semester Questions

1. Explain the principle and construction of an electrostatic voltmeter for very high voltages. What are its merits and demerits for high voltage AC. measurements ?
2. Explain the different methods of high current measurements with their relative merits and demerits.
3. What are the requirements of an oscillograph for impulse and high frequency measurements in high voltage test circuits ?
4. The H. V. arm of an R-C, divider has 15 numbers of 120 ohm resistors with a 20 pF capacitor to ground from each of the junction points. The L.V. arm resistance is 5 ohms. Determine the capacitance needed in the L.V. arm for correct compensation.

8. NON-DESTRUCTIVE TESTING OF MATERIALS AND ELECTRICAL APPARATUS

In order to ensure an economic power-supply system with a high level of reliability, it is important to be able to monitor the dielectric parameters of the various insulations being utilized – when new and in service. Present power systems are ageing significantly and in many cases 40 per cent of the equipment is older than the conventional 'design life' of 25 years.

The condition of high voltage electrical insulation systems used in power cables, power transformers and generators is influenced by a number of manufacturing and operating variables which affect performance and failure

Nondestructive testing - NDT - use test methods to examine an object, material or system without impairing its future usefulness. Non-destructive testing is often required to verify the quality of a product or a system. Commonly used techniques are

AET - Acoustic Emission Testing
ART - Acoustic Resonance Testing
ET - Electromagnetic Testing
IRT - Infrared Testing
LT - Leak Testing
MT - Magnetic Particle Testing
PT - Dye Penetrant Testing
RT - Radiographic Testing
UT - Ultrasonic Testing
VT - Visual Testing (VI - Visual Inspection)

Impedance measurements are a basic means of evaluating electronic components and materials. Every material has a unique set of electrical characteristics that are dependent on its dielectric or insulation properties. Accurate measurements of these properties can provide valuable information to ensure an intended application or maintain a proper manufacturing process.

8.1 Measurement of dc insulation resistance, volume resistance, and surface resistance.

From such measurements and the geometric dimensions of specimen and electrodes, both volume and surface resistivity of electrical insulating materials can be calculated, as well as the corresponding conductances and conductivities

The dc resistance test is used to measure the direct-current (dc) resistance of resistors, electromagnetic windings of components, conductors, etc..

When a dielectric is subjected to a steady state static electric field E the current density J_c is given by
 $J_c = \sigma E$

Assuming a cuboid of the insulating material with thickness d and area A , then

Current $I = J_c A$ and power loss = $VI = VJ_c A = V \sigma EA = V \sigma AV/d = \sigma E^2 \cdot \text{Volume}$.

Therefore, specific dielectric loss = σE^2 Watts/m³.

The conductivity of the insulating materials viz liquid and solid depends upon the temperature and the moisture contents. The leakage resistance R_0 (σ) of an insulating material is determined by measuring the current when a constant d.c. voltage is applied. Since the current is a function of time as different mechanisms are operating simultaneously, so to measure only the conduction current it is better to

measure the current about 1 min after the voltage is switched on. For simple geometries of the specimen (cuboid or cube) specific resistivity ($\rho = 1/\sigma$) can be calculated from the leakage resistance measured. If I is the conduction current measured and V the voltage applied, the leakage resistance is given by $R=V/I=d/\sigma A$, where d is the thickness of the specimen and A is the area of section.

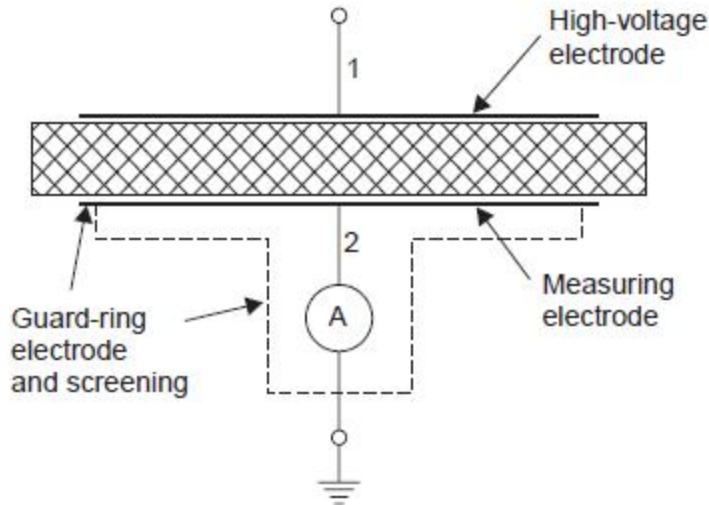

Fig. 8.1. Simple arrangement for measurement of resistivity of the insulating material.

The d.c. voltage of 100 volt or 1000 volt is applied between electrode 1 and the earth. The measuring electrode 2 is earthed through a sensitive ammeter. The third electrode known as guard ring electrode surrounds the measuring electrode and is directly connected to ground so as to eliminate boundary field effects and surface currents. The width of the guard electrode should be at least twice the thickness of the specimen and the unguarded electrode (1) must extend to the outer edge of the guard electrode. The gap between electrode 2 and 3 should be as small as possible. A thin metallic foil usually of aluminium or lead of about 20 μm thickness is placed between the electrodes and specimen for better contact. The specific conductivity for most of the insulating material lies in the range of 10^{-16} to 10^{-10} S/cm, which gives currents to be measured of these specimen to be of the order of picoamperes or nanoamperes. The measuring leads should be appropriately and carefully screened. The measurement of conduction current using d.c. voltage not only provides information regarding specific resistivity of the material but it gives an idea of health of the insulating material. If conduction currents are large, the insulating properties of the material are lost. This method, therefore, has proved very good in the insulation control of large electrical machines during their period of operation.

8.2 Measurement of Dielectric Constant

The measurement of dielectric constant, also known as relative permittivity of a material, is one of the most popular methods of evaluating insulators such as rubber, plastics, and powders. It is used to determine the ability of an insulator to store electrical energy. The complex dielectric constant consists of a real part (k'), which represents the storage capability and an imaginary part (D), which represents the loss.

Dielectric constant measurements can be performed easier and faster than chemical or physical analysis techniques making them an excellent material analysis tool

8.3 Measurement of Dissipation Factor

Dissipation factor (D) is defined as the ratio of an insulating materials resistance to its capacitive reactance at a specified frequency. It measures the inefficiency or loss of the material, is always greater than 0, but usually much smaller than the dielectric constant. D measurements are an excellent means of quality control which can yield indication of contamination or deterioration. For example, if we wanted to check the purity of epoxy or some raw material for consistency in a production run why not just measure the D. Excessive moisture would increase the dissipation factor value telling us something has changed as compared to previously established values.

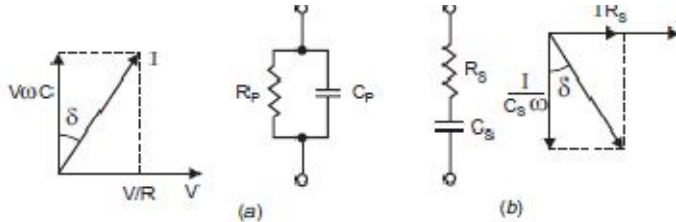

Fig.8.2 Equivalent circuit representation for dielectric loss

The dielectric conductivity takes into account all the three power dissipative processes including the one which is frequency dependent. Fig. 8.2 shows two equivalent circuits representing the electrical behaviour of insulating materials under a.c. voltages, losses have been simulated by resistances.

Normally the angle between V and the total current in a pure capacitor is 90° . Due to losses, this angle is less than 90° . Therefore, δ is the angle by which the voltage and charging current fall short of the 90° displacement.

$$\tan\delta = 1/(\omega C_p R_p)$$

whereas for series circuit $\tan\delta = (\omega C_s R_s)$

8.3.1 HIGH VOLTAGE SCHERING BRIDGE

The bridge is widely used for capacity and dielectric loss measurement of all kinds of capacitances, for instance cables, insulators and liquid insulating materials. We know that most of the high voltage equipments have low capacitance and low loss factor. This bridge is then more suitable for measurement of such small capacitance equipments as the bridge uses either high voltage or high frequency supply. If measurements for such low capacity equipments is carried out at low voltage, the results so obtained are not accurate.

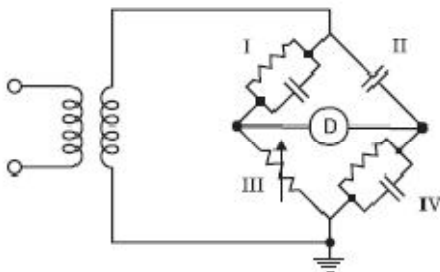

Fig.8.3 High Voltage Schering Bridge

Special features of the bridge

- 1.High Voltage supply
- 2.Screened Standard Capacitor
- 3.Large impedance of arm I &II
- 4.Null Detector
- 5.Automatic Guard Potential Regulator

The bridge is balanced by successive variation of R_1 and C_2 until on the oscilloscope (Detector) a horizontal straight line is observed.

$$\tan\delta = (\omega C_2 R_2)$$
$$C_p = \cos^2\delta C_s R_2 / R_1.$$

Problem

1.A 33kv 50Hz HV Schering bridge is used to test a simple insulation. The various aims have the given parameters on balance. The standard capacitance 500pf, the resistive branch 800 ohms and branch with parallel combination of resistance and capacitance has 180 ohms and 0.15 μ F. Determine the value of the capacitance of this sample, its parallel equivalent loss resistance, power factor and power loss under these test conditions.

8.4 Partial Discharges

Partial discharge is defined as localised discharge process in which the distance between two electrodes is only partially bridged *i.e.*, the insulation between the electrodes is partially punctured. Partial discharges may originate directly at one of the electrodes or occur in a cavity in the dielectric. Some of the typical partial discharges are: (i) Corona or gas discharge. These occur due to non-uniform field on sharp edges of the conductor subjected to high voltage especially when the insulation provided is air or gas or liquid(cf.Fig.8.4a) (ii) Surface discharges and discharges in laminated materials on the interfaces of different dielectric material such as gas/solid interface as gas gets over stressed ϵ_r times the stress on the solid material (where ϵ_r is the relative permittivity of solid material) and ionization of gas results(cf.Fig.8.4b & c) (iii) Cavity discharges: When cavities are formed in solid or liquid insulating materials the gas in the cavity is over stressed and discharges are formed (cf.Fig.8.4d) (iv). Treeing Channels: High intensity fields are produced in an insulating material at its sharp edges and this deteriorates the insulating material. The continuous partial discharges so produced are known as Treeing Channels(cf.Fig.8.4e)

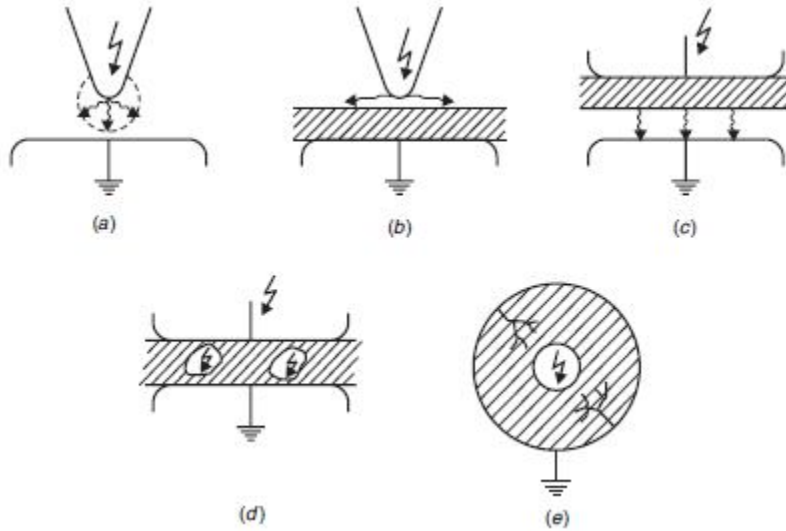

Fig. 8.4 Various Partial Discharges

External partial discharge is the process which occurs external to the equipment e.g. on overhead lines, on armature etc.

Internal Partial Discharge

Internal partial discharge is a process of electrical discharge which occurs inside a closed system (discharge in voids, treeing etc). This kind of classification is essential for the PD measuring system as

external discharges can be nicely distinguished from internal discharges. Partial discharge measurement have been used to assess the life expectancy of insulating materials. Even though there is no well defined relationship, yet it gives sufficient idea of the insulating properties of the material. Partial discharges on insulation can be measured not only by electrical methods but by optical, acoustic and chemical method also. The measuring principles are based on energy conversion process associated with electrical discharges such as emission of electromagnetic waves, light, noise or formation of chemical compounds. The oldest and simplest but less sensitive is the method of listening to hissing sound coming out of partial discharge. A high value of loss factor $\tan \delta$ is an indication of occurrence of partial discharge in the material. This is also not a reliable measurement as the additional losses generated due to application of high voltage are localised and can be very small in comparison to the volume losses resulting from polarization process. Optical methods are used only for those materials which are transparent and thus not applicable for all materials. Acoustic detection methods using ultrasonic transducers have, however, been used with some success. The most modern and the most accurate methods are the electrical methods. The main objective here is to separate impulse currents associated with PD from any other phenomenon.

8.4.1 The basic PD test circuit

For the evaluation of the fundamental quantities related to a PD pulse we simulate the test object, as usual, by the simple capacitor arrangement as shown in Fig. 8.5(a), comprising solid or fluid dielectric materials between the two electrodes or terminals A and B, and a gas-filled cavity. The electric field distribution within this test object is here simulated by some partial capacitances, which is possible as long as no space charges disturb this distribution. Electric field lines within the cavity are represented by C_c and those starting

or ending at the cavity walls form the two capacitances C_b' and C_b'' within the solid or fluid dielectric. All field lines outside the cavity are represented by $C_a = C_a' + C_a''$. Due to realistic geometric dimensions involved $C_b = C_b' + C_b''$ ($C_b' + C_b''$) the magnitude of the capacitances will then be controlled by the inequality $C_a \gg C_c \gg C_b$.

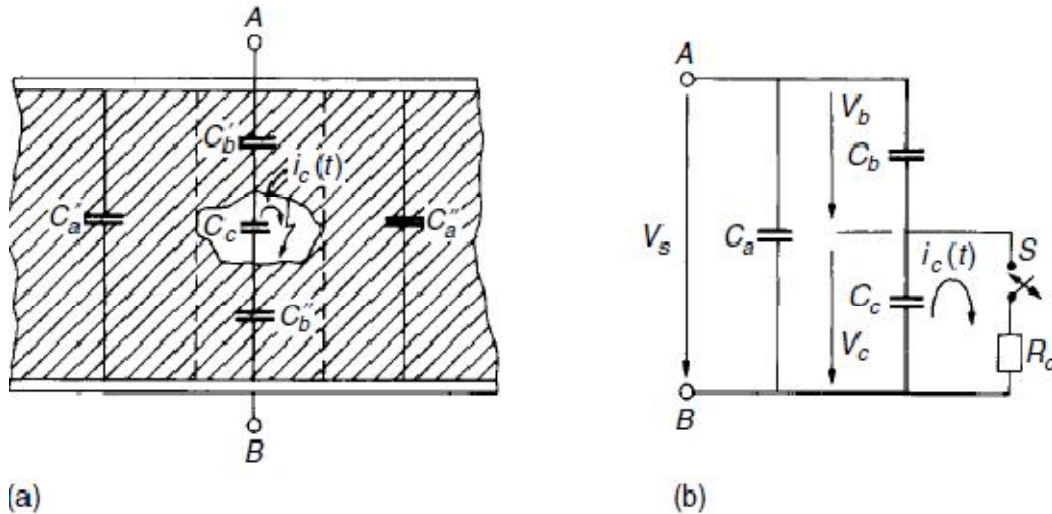

Fig.8.6 Equivalent circuit representing PD.

9.High Voltage Testing of Electrical Apparatus

Electrical equipment must be capable of withstanding overvoltages during operation. Thus by suitable testing procedure we must ensure that this is done. High voltage testing can be broadly classified into testing of insulating materials (samples of dielectrics) and tests on completed equipment. The tests carried out on samples of dielectric consist generally of the measurement of permittivity, dielectric loss per unit volume, and the dielectric strength of the material. The first two can be measured using the High Voltage Schering Bridge. The tests carried out on completed equipment are the measurement of capacitance, the power factor or the total dielectric loss, the ultimate breakdown voltage and the flash-over voltage. The breakdown voltage tests on completed equipment is only done on a few samples since it permanently damages and destroys the equipment from further use. However since all equipment have to stand up to a certain voltage without damage under operating conditions, all equipment are subjected to withstand tests on which the voltage applied is about twice the normal voltage, but which is less than the breakdown voltage.

In alternating voltage system, a careful choice of the characteristics of the testing transformer is essential. It is known that the flash over voltage of the insulator in air or in any insulating fluid depends upon the capacitance of the supply system. This is due to the fact that a voltage drop may not maintain preliminary discharges or breakdown. It is, therefore, suggested that a capacitance of at least 1000 pF must be connected across the insulator to obtain the correct flash over or puncture voltage and also under breakdown condition (a virtual short circuit) the supply system should be able to supply at least 1 amp for clean and 5 amp for polluted insulators at the test voltage.

There are some difficult problems with impulse testing equipments also especially when testing large power transformers or large reactors or large cables operating at very high voltages.

9.1 TESTING OF OVERHEAD LINE INSULATORS

High voltage testing of electrical equipment requires two types of tests: (i) Type tests, and (ii)

Routine test. Type tests involves quality testing of equipment at the design and development level *i.e.* samples of the product are taken and are tested when a new product is being developed and designed or an old product is to be redesigned and developed whereas the routine tests are meant to check the quality of the individual test piece. This is carried out to ensure quality and reliability of individual test objects.

High voltage tests include (i) Power frequency tests and (ii) Impulse tests. These tests are carried out on all insulators.

- (i) 50% dry impulse flash over test.
- (ii) Impulse withstand test.
- (iii) Dry flash over and dry one minute test.
- (iv) Wet flash over and one minute rain test.
- (v) Temperature cycle test.
- (vi) Electro-mechanical test.
- (vii) Mechanical test.
- (viii) Porosity test.
- (ix) Puncture test.
- (x) Mechanical routine test.

If the test is carried out under artificial rain, it is called wet flash over test. The insulator is subjected to spray of water of following characteristics:

Precipitation rate $3 \pm 10\%$ mm/min.

Direction 45° to the vertical

Conductivity of water 100 micro siemens $\pm 10\%$

Temperature of water Ambient $+15^\circ\text{C}$

The insulator with 50% of the one-min. rain test voltage applied to it, is then sprayed for two minutes, the voltage raised to the one minute test voltage in approximately 10 sec. and maintained there for one minute. The voltage is then increased gradually till flash over occurs and the insulator is then flashed at least four more times, the time taken to reach flash over voltage being in each case about 10 sec. The flash over voltage must not be less than the value specified in specifications.

9.2 TESTING OF CABLES

High voltage power cables have proved quite useful especially in case of HV d.c. transmission. Underground distribution using cables not only adds to the aesthetic looks of a metropolitan city but it provides better environments and more reliable supply to the consumers.

A cable is subjected to following tests:

- (i) Bending tests.
- (ii) Loading cycle test.
- (iii) Thermal stability test.
- (iv) Dielectric thermal resistance test.
- (v) Life expectancy test.
- (vi) Dielectric power factor test.
- (vii) Power frequency withstand voltage test.
- (viii) Impulse withstand voltage test.
- (ix) Partial discharge test.

High Voltage Schering Bridge is used to perform dielectric power factor test on the cable sample. The power factor is measured for different values of voltages *e.g.* 0.5, 1.0, 1.5 and 2.0 times the rated operating voltages. The maximum value of power factor at normal working voltage does not exceed a specified value (usually 0.01) at a series of temperatures ranging from 15°C to 65°C . The difference in the power factor between rated voltage and 1.5 times the rated voltage and the rated voltage and twice the rated voltage does not exceed a specified value. Sometimes the source is not able to supply charging current required by the test cable, a suitable choke in series with the test cable helps in tiding over the situation.

Partial discharge measurement of cables is very important as it gives an indication of expected

life of the cable and it gives location of fault, if any, in the cable. When a cable is subjected to high voltage and if there is a void in the cable, the void breaks down and a discharge takes place. As a result, there is a sudden dip in voltage in the form of an impulse.

This impulse travels along the cable as explained in detail in Chapter VI. The duration between the normal pulse and the discharge pulse is measured on the oscilloscope and this distance gives the location of the void from the test end of the cable. However, the shape of the pulse gives the nature and intensity of the discharge. In order to scan the entire length of the cable against voids or other imperfections, it is passed through a tube of insulating material filled with distilled water. Four electrodes, two at the end and two in the middle of the tube are arranged. The middle electrodes are located at a stipulated distance and these are energized with high voltage. The two end electrodes and cable conductor are grounded. As the cable is passed between the middle electrode, if a discharge is seen on the oscilloscope, a defect in this part of the cable is stipulated and hence this part of the cable is removed from the rest of the cable.

9.3 TESTING OF BUSHINGS

Bushings are an integral component of high voltage machines. A bushing is used to bring high voltage conductors through the grounded tank or body of the electrical equipment without excessive potential gradients between the conductor and the edge of the hole in the body. The bushing extends into the surface of the oil at one end and the other end is carried above the tank to a height sufficient to prevent breakdown due to surface leakage. Following tests are carried out on bushings:

(i) Power Factor Test

The bushing is installed as in service or immersed in oil. The high voltage terminal of the bushing is connected to high voltage terminal of the Schering Bridge and the tank or earth portion of the bushing is connected to the detector of the bridge. The capacitance and p.f. of the bushing is measured at different voltages as specified in the relevant specification and the capacitance and p.f. should be within the range specified.

(ii) Impulse Withstand Test

The bushing is subjected to impulse waves of either polarity and magnitude as specified in the standard specification. Five consecutive full waves of standard wave form are applied and if two of them cause flash over, the bushing is said to be defective. If only one flash over occurs, ten additional applications are made. If no flash over occurs, bushing is said to have passed the test.

(iii) Chopped Wave and Switching Surge Test

Chopped wave and switching surge of appropriate duration tests are carried out on high voltage bushings. The procedure is identical to the one given in (ii) above.

(iv) Partial Discharge Test

In order to determine whether there is deterioration or not of the insulation used in the bushing, this test is carried out.

(v) Visible Discharge Test at Power Frequency

The test is carried out to ascertain whether the given bushing will give rise to ratio interference or not during operation. The test is carried out in a dark room. The voltage as specified is applied to the bushing (IS 2099). No discharge other than that from the grading rings or arcing horns should be visible.

(vi) Power Frequency Flash Over or Puncture Test

(Under Oil): The bushing is either immersed fully in oil or is installed as in service condition. This test is carried out to ascertain that the internal breakdown strength of the bushing is 15% more than the power frequency momentary dry withstand test value.

9.4 TESTING OF POWER TRANSFORMERS

Transformer is one of the most expensive and important equipment in power system. If it is not suitably designed its failure may cause a lengthy and costly outage. Therefore, it is very important to be cautious while designing its insulation, so that it can withstand transient over voltage both due to switching and lightning. The high voltage testing of transformers is, therefore, very important and would be discussed here. Other tests like temperature rise, short circuit, open circuit etc. are not considered here. However, these can be found in the relevant standard specification.

Partial Discharge Test

The test is carried out on the windings of the transformer to assess the magnitude of discharges. The transformer is connected as a test specimen similar to any other equipment and the discharge measurements are made. The location and severity of fault is ascertained using the travelling wave theory technique. The measurements are to be made at all the terminals of the transformer and it is estimated that if the apparent measured charge exceeds 10^4 picocoulombs, the discharge magnitude is considered to be severe and the transformer insulation should be so designed that the discharge measurement should be much below the value of 10^4 pico-coulombs.

Impulse Testing of Transformer

The impulse level of a transformer is determined by the breakdown voltage of its minor insulation (Insulation between turn and between windings), breakdown voltage of its major insulation (insulation between windings and tank) and the flash over voltage of its bushings or a combination of these. The impulse characteristics of internal insulation in a transformer differs from flash over in air in two main respects. Firstly the impulse ratio of the transformer insulation is higher (varies from 2.1 to 2.2) than that of bushing (1.5 for bushings, insulators etc.). Secondly, the impulse breakdown of transformer insulation is practically constant and is independent of time of application of impulse voltage.

Impulse testing consists of the following steps:

- (i) Application of impulse of magnitude 75% of the Basic Impulse Level (BIL) of the transformer under test.
- (ii) One full wave of 100% of BIL.
- (iii) Two chopped wave of 115% of BIL.
- (iv) One full wave of 100% BIL and
- (v) One full wave of 75% of BIL.

During impulse testing the fault can be located by general observation like noise in the tank or smoke or bubble in the breather. If there is a fault, it appears on the Oscilloscope as a partial of complete collapse of the applied voltage. Study of the wave form of the neutral current also indicated the type of fault. If an arc occurs between the turns or from turn to the ground, a train of high frequency pulses are seen on the oscilloscope and wave shape of impulse changes. If it is a partial discharge only, high frequency oscillations are observed but no change in wave shape occurs.

9.5 TESTING OF CIRCUIT BREAKERS

An equipment when designed to certain specification and is fabricated, needs testing for its performance. The general design is tried and the results of such tests conducted on one selected breaker and are thus applicable to all others of identical construction. These tests are called the type tests. These tests are classified as follows:

1. Short circuit tests:

- (i) Making capacity test.
- (ii) Breaking capacity test.
- (iii) Short time current test.
- (iv) Operating duty test

2. Dielectric tests:

- (i) Power frequency test:
 - (a) One minute dry withstand test.
 - (b) One minute wet withstand test.
- (ii) Impulse voltage dry withstand test.

3. Thermal test. 4. Mechanical test

9.6 Tests on Lightning arrestors or surge diverters

For the normal or operating power frequency voltages, the lightning arrestor has to be a non conductor. It should behave as a short circuit for transient over-voltages of impulse character, discharge the heavy current, and recover its insulation without allowing the follow-up of the power frequency current.

The surge diverters need to be tested at the following current ratings.

| Diverter Class | Diverter Rating | Impulse current rating(8/20 μ s) |
|----------------|-----------------|--------------------------------------|
|----------------|-----------------|--------------------------------------|

| | | |
|---|-------------------------------|--------------|
| A | 230V-600V | 1500-2500Amp |
| B | 400V-33kV(distribution Class) | 5kA |
| C | Station Type | 10kA |

Tests on surge diverters

Power frequency spark over test (Routine test)

Hundred percent standard impulse spark-over test

Front of wave spark-over test

Residual voltage test

The power frequency spark-over test is conducted using a series resistor(for current limitation in use of flashover) at 1.5 times the rated value for five successive applications under both dry and wet conditions.

The arrester should operate when a lightning occurs. To ascertain it standard impulse voltage of specified magnitude is applied. The arrester has to spark-over every times in each time of the ten successive applications both under positive as well as under negative polarity impulse. This is hundred percent standard impulse spark-over test.

Front of wave spark-over test- for steep fronted impulse wave with rate of rise 100kV/ μ s, for 12kV rating.

The arrester must spark –over every time. The time to spark-over is also measured using oscilloscope and camera. The volt-time characteristics of the divider is plotted and the intersection of V-T ch. And the line with the slope of virtual steepness of the front give the front of wave spark-over voltage.

Residual voltage test: the residual voltage is the voltage developed across the non-linear resistor units during the flow of surge current. Standard impulse current of rated magnitude are applied and the voltage is measured by CRO and divider. The magnitude of currents are approximately 0.5, 1.0 and 2.0 time the rated value.

9.7 RADIO INTERFERENCE MEASUREMENTS

Many electrical apparatuses like transformers, line conductors, rotating machines, etc. produce unwanted electrical signals in the radio and high frequency (television band, microwave bands, etc.) ranges. These signals arise due to corona discharges in air, internal or partial discharges in the insulation, sparking at commutators and brush gear in rotating machines, etc. It is important to see that the noise voltages generated in the radio and other transmission bands are limited to acceptable levels, and hence the radio interference voltage measurements are of importance. It has been found that the surface conditions of the overhead conductors subjected to high voltage stresses and varying atmospheric conditions greatly influence the magnitude of the noise voltage produced. In case of solid insulators, the bonding between the porcelain and the metal pin, the binding of high voltage conductor and the insulator surface, and the surface pollution were found to be the sources of this noise.

The noise generated in the radio frequency band as a result of corona or partial discharges in high voltage power apparatus may be measured

- (i) by the radio frequency line to ground voltage known as the radio influence voltage or RIV, and
- (ii) as an interfering field by means of an antenna known as the radiated radio interference voltage or RI.

Normally, the tests and measurements done in the laboratories are RIV measurements, whereas field investigations with portable radio receivers are RI measurements.

A radio noise meter (consisting of a portable radio receiver with a local oscillator, a radio frequency amplifier, a mixer, an intermediate frequency amplifier, and a detector similar to that of a standard radio receiver) is used in the laboratory and operates in the frequency range 150 kHz to 30 MHz. In addition, the radio noise meter has multiinput circuits to accommodate a number of pick-up devices, attenuators, calibrators, and output circuits containing special detectors and meters. The detector circuit consists of a diode detector in series with a series resistance R_s , charging a parallel $R-C$ circuit. The detector circuit is provided with a measuring device to measure either (a) the average value, (b) the peak value, or

(c) quasi-peak value (the quasi-peak value of the impulse noise is equal to the rms value of the sine wave at the centre frequency of the pass band which produces the same deflection in the meter scale as that of the impulse). The voltmeter provided at the end of the detector has an input impedance of 50 to 75 Ω .

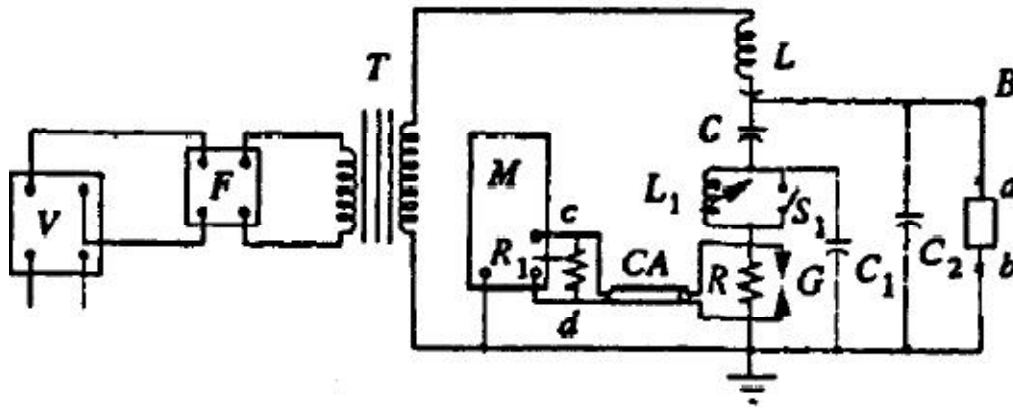

Fig.8.7 Schematic diagram of circuit for measurement of RIV of high Voltage apparatus in 150kHz to 30MHz frequency range.

F-Voltage control unit, V-Voltmeter, T-High Voltage Transformer, L-Radio frequency choke, C-Coupling condenser, R_1 -Meter input impedance, M-Radio Noise Meter, A,b-Test apparatus, CA-Co-axial cable, G-Protective Gap, S_1 -Shorting Switch C_1C_2 -Stray capacitances, L_1 -Tuning choke, R-Measuring impedance.

Probable end semester questions

- 1.Explain the importance of RIV measurements for EHV power apparatus.
- 2.Explain, with a schematic diagram, one method of measuring RIV of transmission line hardware



UNIT - I

OVER VOLTAGES IN ELECTRICAL POWER SYSTEMS



LIGHTNING

- Causes of over voltage
- Lightning phenomenon
- Charge formation of Lightning
- Rate of Charging of thunder cloud
- Mechanism of lightning strokes
- Characteristics of Lightning strokes



LIGHTING

- Factors contributing to good line design
- Protection afforded by ground wires.
- Tower footing resistance
- Interaction between lightning and power system
- Mathematical model of Lightning



Causes of Lightning

- Lightning phenomenon
 - peak discharge in which charge accumulated in the cloud into neighbouring cloud or to the ground
- Electrode separation – cloud to cloud or cloud to ground is about 10 km or more



CHARGE FORMATION OF CLOUD

- Positive and negative charges become separated by heavy air current with ice crystals in the upper part and rain in the lower region.
- Charge separation depends on height of cloud (200 – 10,000m).
- Charge centers at a distance about 300 – 2km



CHARGE FORMATION OF CLOUD

- Charge inside the cloud – 1 to 100 C
- Cloud potential – 10^7 to 10^8 V
- Gradient within a cloud – 100 V/cm
- Gradient at initial discharge point – 10kV/cm
- Energy at discharge – 250 kWhr

CHARGE FORMATION OF CLOUD

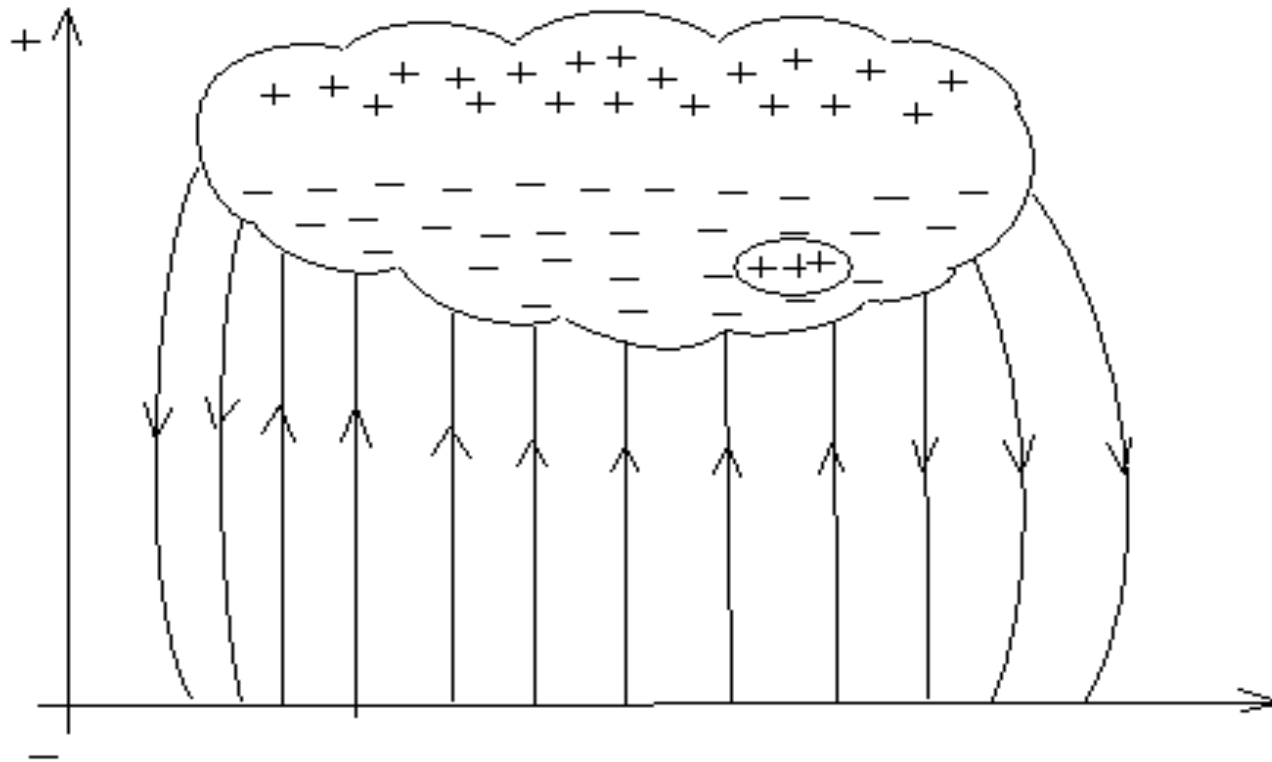



MECHANISM OF LIGHTNING FLASH

- Pilot streamer and Stepped leader
- Ground streamer and return stroke
- Subsequent strokes

PILOT STREAMER AND STEEPED LEADER

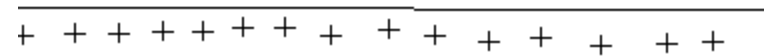
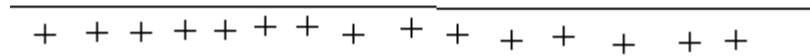
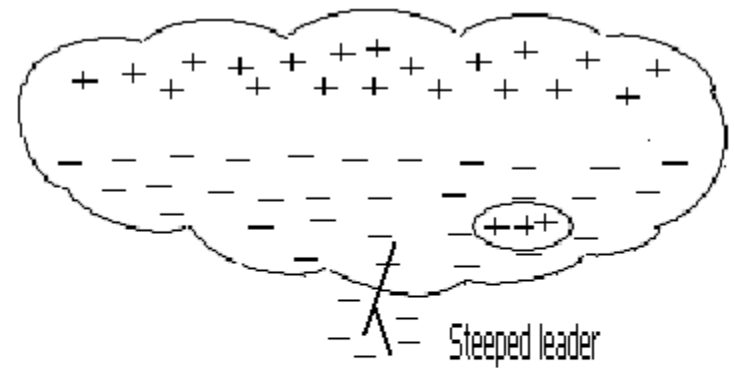
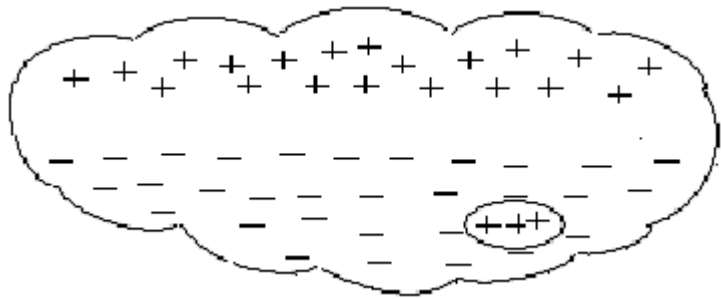

GROUND STREAMER AND RETURN STROKE

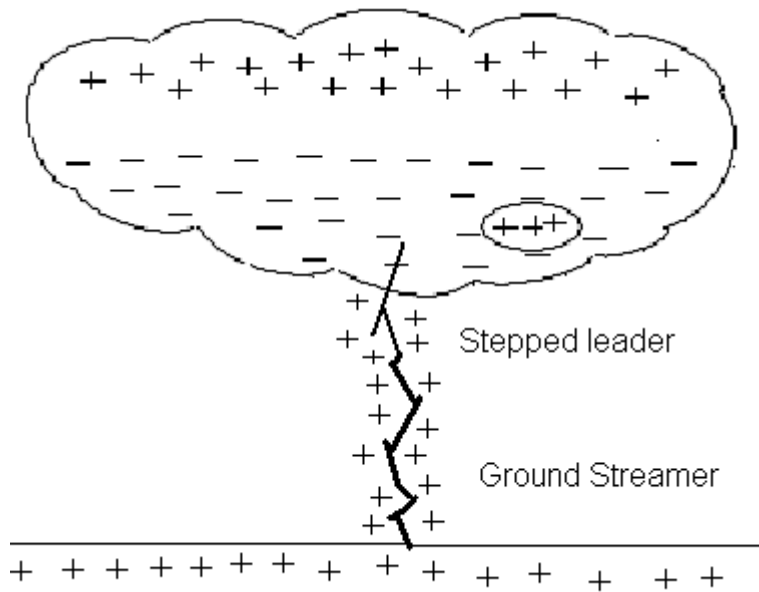
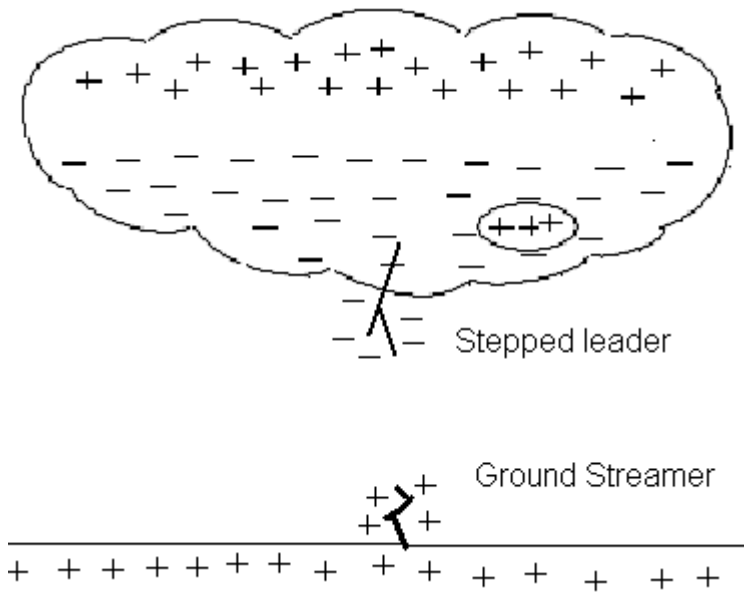



CHARACTERISTICS OF LIGHTNING STROKES

- Current-time characteristics
- Time to peak or Rate of rise
- Probability distribution of current and time
- Wave shapes of lightning voltage and current



LIGHTNING CURRENT

- Short front time - $10\mu\text{s}$
- Tail time – several ms.



RATE OF RISE

- 50% lightning stroke current – greater than $7.5\text{kA}/\mu\text{s}$.
- 10% lightning strokes current – exceeds $25\text{ kA}/\mu\text{s}$.
- Stroke current above half value – more than $30\mu\text{s}$.

SURGE VOLTAGE



- Maximum surge voltage in transmission line – 5MV
- Most of the surge voltage is less than 1000 kV on line.
- Front time – 2 to 10 μs
- Tail time – 20 to 100 μs
- Rate of rise of voltage – 1MV/ μs



LIGHTNING STROKES

- Direct stroke
 - directly discharges on to transmission line or line wires
- Induced stroke
 - cloud generates negative charge at its base, the earth object develop induced positive charge



OVER VOLTAGE DUE TO SWITCHING SURGES

INTRODUCTION

- In switching, the over voltage thus generated last for longer durations and therefore are severe and more dangerous to the system
- The switching over voltages depends on the normal voltage of the system and hence increase with increased system voltage



ORIGIN OF SWITCHING SURGES

- Making and breaking of electric circuits with switchgear may results in abnormal over voltages in power systems having large inductances and capacitances.
- over voltages may go as high as 6 times the normal power frequency voltage.

ORIGIN OF SWITCHING SURGES

- In circuit breaking operation switching surges with a high rate of rise of voltage may cause repeated restriking of the arc between the contacts of a circuit breaker, thereby causing destruction of the circuit breaker contacts.
- Switching surges may include high natural frequencies of the system, a damped normal frequency voltage component, or restriking and recovery voltage of the system with successive reflected waves from terminations.



CHARACTERISTICS OF SWITCHING SURGES

- De-energizing of transmission lines, cables, shunt capacitor, banks, etc.
- Disconnection of unloaded transformers, reactors, etc.
- Energization or reclosing of lines and reactive loads.
- Sudden switching off of loads.
- Short circuit and fault clearances.
- Resonance phenomenon like ferro-resonance, arcing grounds, etc.



CONTROL OF OVERVOLTAGES DUE TO SWITCHING

- Energization of transmission lines in one or more steps by inserting resistances and withdrawing them afterwards.
- Phase controlled closing of circuit breakers.
- Drainage of trapped charges before reclosing
- Use of shunt reactors.
- Limiting switching surges by suitable surge diverters.

PROTECTION AGAINST OVERVOLTAGES



- Minimizing the lightning overvoltages are done by suitable line designs,
- Providing guard and ground wires,
- Using surge diverters.

PROTECTION AGAINST OVERVOLTAGE



- Shielding the overhead lines by using ground wires above the phase wires,
- Using ground rods and counter-poise wires,
- Including protective devices like explosion gaps, protector tubes on the lines, and surge diverters at the line terminations and substations



UNIT - II

ELECTRICAL BREAKDOWN IN
GASES, SOLIDS AND LIQUIDS.

GASEOUS BREAKDOWN IN UNIFORM FIELDS

In uniform fields, the Townsend's criterion for breakdown in electropositive gases is given by the following equation,

$$\gamma (e^{\alpha d} - 1) = 1$$
$$\alpha d = \ln (1 / \gamma + 1)$$

- where the coefficients α and γ are functions of E/p and are given as follows

$$\alpha = p f_1 \left(\frac{E_0}{p} \right) \quad \gamma = f_2 \left(\frac{E_0}{p} \right)$$

GASEOUS BREAKDOWN IN UNIFORM FIELDS

where E_0 is the applied electric field, and p the gas pressure. In a uniform field electrode system of gap distance d ,

$$E_b = \frac{U_b}{d}$$

U_b is the breakdown voltage and E_b the corresponding field intensity. E_b is equal to the electric strength of the dielectric under given conditions. When the applied field intensity $E_0 = E_b$

$$f_2\left(\frac{U_b}{pd}\right) \left\{ \exp \left[pd f_1\left(\frac{U_b}{pd}\right) \right] - 1 \right\} = 1$$
$$U_b = f(pd)$$

GASEOUS BREAKDOWN IN UNIFORM FIELDS

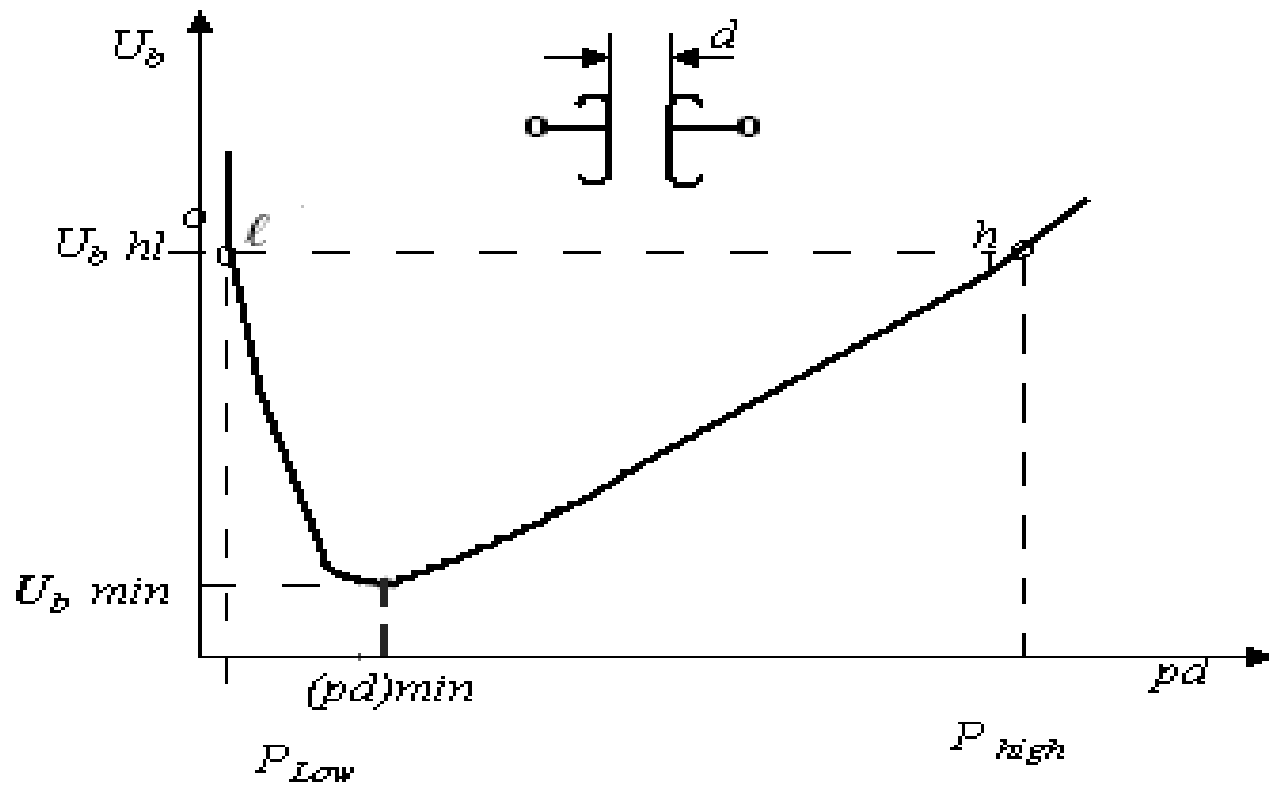

BREAKDOWN IN LIQUID DIELECTRICS



- A very large number of external factors affect the breakdown strength of liquid dielectrics.
- For example, electrode configuration, their material, size and surface finish, the type of voltage, its period of application and magnitude, the temperature, pressure, purification of the liquid and its ageing condition.

BREAKDOWN IN LIQUID DIELECTRICS



- Dissolved water, gas or the presence of any other form of contamination and sludge also affect the breakdown strength considerably.
- It is, therefore, not possible to describe the breakdown mechanism by a single theoretical analysis which may take into account all known observed factors affecting the breakdown.



CORONA DISCHARGE

- The field is non-uniform, an increase in voltage will first cause a discharge in the gas to appear at points with highest electric field intensity, namely at sharp points or where the electrodes are curved or on transmission lines. This form of discharge is called a corona discharge and can be observed as a bluish luminescence.



CORONA DISCHARGE

- This is accompanied by a hissing noise.
- The air surrounding the corona region becomes converted into ozone.
- It is responsible for considerable loss of power from high voltage transmission lines,
- It leads to the deterioration of insulation due to the combined action of the bombardment of ions and of the chemical compounds formed during discharges.
- It also gives rise to radio interference.

BREAKDOWN IN NON-UNIFORM FIELDS



- The breakdown voltages were also observed to depend on humidity in air.
- In rod gaps the fields are non-uniform.
- In the case of sphere gaps the field is uniform
- In sphere gaps, the breakdown voltage do not depend on humidity and are also independent of the voltage waveform
- The formative time lag is quite small ($\sim 0.5\mu\text{s}$) even with 5% over-voltage.



VACUUM BREAKDOWN

It can be broadly divided into following categories

- Particle exchange mechanism.
- Field emission mechanism.
- Clump theory



CONDUCTION & BREAKDOWN IN COMMERCIAL LIQUIDS

- Suspended particle mechanism
- Cavitation and bubble mechanism
- Stressed oil volume mechanism
- Thermal mechanism of breakdown



BREAKDOWN IN SOLID DIELECTRICS

- Chemical & electrochemical deterioration & breakdown
- Breakdown due to treeing and tracking
- Breakdown due to internal discharges



BREAKDOWN IN COMPOSITE DIELECTRICS

- Mechanism of breakdown in composite dielectric
 1. Short-term breakdown
 2. Long-term breakdown



CONDUCTION & BREAKDOWN IN PURE LIQUIDS

- Low electric fields less than 1 kV/cm are applied, conductivities of 10^{-18} – 10^{-20} mho/cm are obtained.
- These are due to impurities remaining after purification
- When the fields are high the currents not only increase rapidly.



UNIT III

GENERATION OF HIGH VOLTAGES AND HIGH CURRENTS



GENERATION OF HIGH D.C VOLTAGE

DIFFERENT METHODS TO GENERATE HIGH D,C VOLTAGE:

1. Half and full wave rectifier circuits
2. Voltage doubler circuits
3. Voltage multiplier circuits
4. Van de Graaff generator

HALF AND FULL WAVE RECTIFIER CIRCUITS

- This method can be used to produce DC voltage up to 20 kV
- For high voltages several units can be connected in series
- For the first half cycle of the given AC input voltage, capacitor is charged to V_{max} and for the next half cycle the capacitor is discharged to the load
- The capacitor C is chosen such that the time constant CR_1 is 10 times that of AC supply

VOLTAGE DOUBLER CIRCUIT

- In this method, during –ve half cycle, the Capacitor C_1 is charged through rectifier R to a voltage $+V_{\max}$. During next cycle C_1 rises to $+2V_{\max}$.
- C_2 is charged to $2V_{\max}$.
- Cascaded voltage doublers can be used for producing larger output voltage

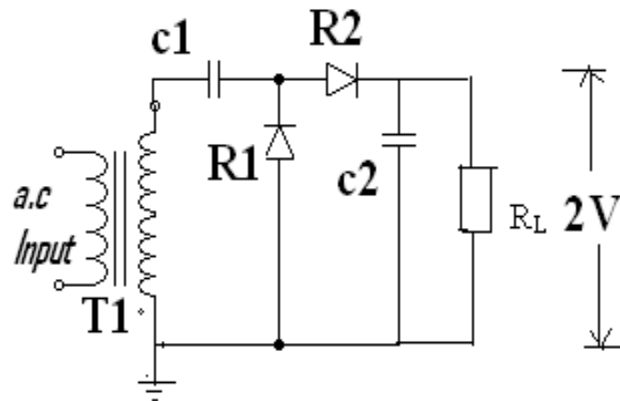

Simple voltage doubler

CASCADED VOLTAGE DOUBLERS

- Cascaded voltage doublers can be used for producing larger output voltage

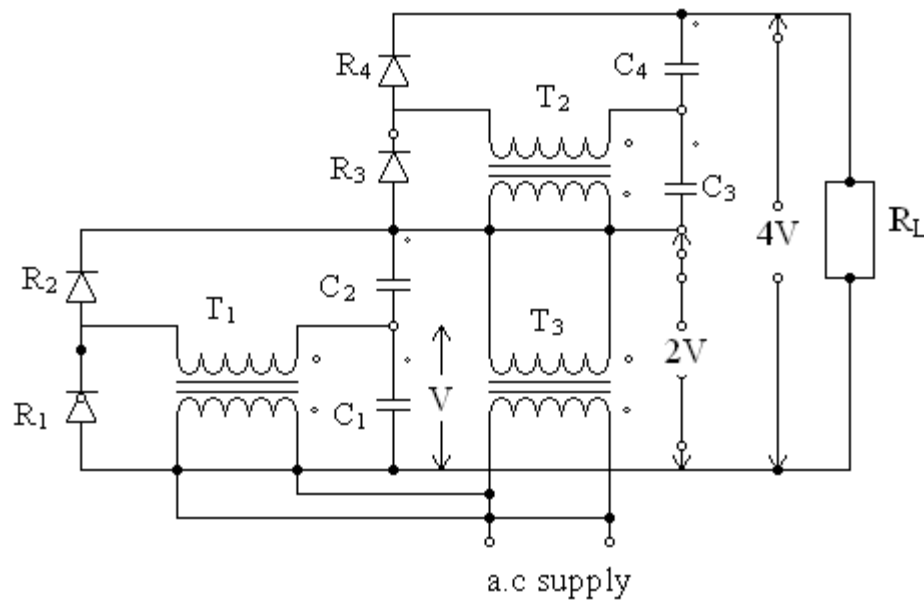

VOLTAGE MULTIPLIER CIRCUITS

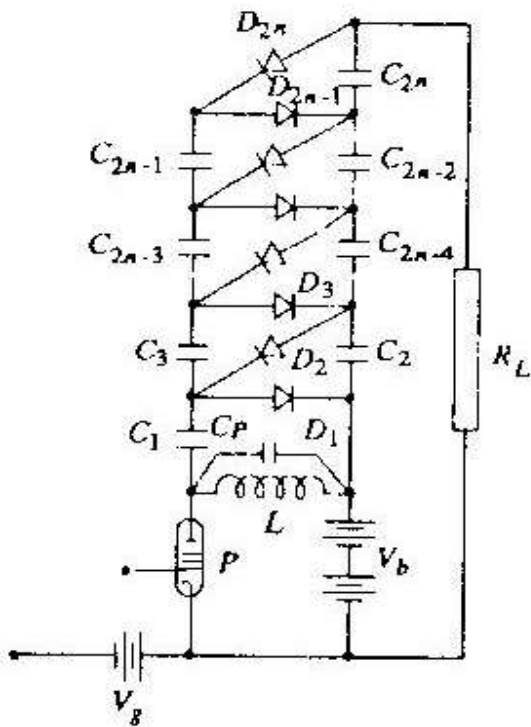

- Here n no. of capacitors and diodes are used.
- Voltage is cascaded to produce output of $2nV_{\max}$.
- Voltage multiplier circuit using Cockcroft-Walton principle can be used.

VAN DE GRAFF GENERATOR

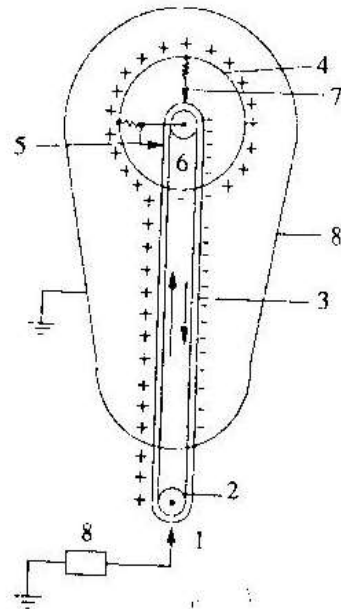

Van de Graaff generator

- In electrostatic machines charged bodies are moved in an electrostatic field
- If an insulated belt with a charge density δ moves in an electric field between two electrodes with separation 's'
- If the belt moves with a velocity v then mechanical power require to move the belt is $P=F.v=V.I$

1. Lower spray point
2. Motor driven pulley
3. Insulated belt
4. High voltage terminal
5. Collector
6. Upper pulley insulated from terminal
7. Upper spray point
8. Earthed enclosure



Electrostatic generator

- It consists of a stator with interleaved rotor vanes forming a variable capacitor and operates in vacuum
- The power input into the circuit $P=VI=CVdV/dt+V^2dC/dt$
- The rotor is insulated from the ground, maintained at a potential of $+V$.
- The rotor to stator capacitance varies from C_0 to C_m
- Stator is connected to a common point between two rectifiers across $-E$ volts.
- As the rotor rotates, the capacitance decreases and the voltage across C increases.
- Output voltage of 1MV can be generated.



GENERATION OF HIGH ALTERNATING VOLTAGES

- When test voltage requirements are less than about 300 kV, a single transformer can be used.
- Each transformer unit consists of low, high and meter winding.
- Series connection of the several units of transformers used to produce very high voltage.



CASCADE TRANSFORMERS

- First transformer is at ground potential along with its tank. The 2nd transformer is kept on insulators and maintained at a potential of V_2 .
- The high voltage winding of the 1st unit is connected to the tank of the 2nd unit, the low voltage winding of this unit is supplied from the excitation winding of the 1st transformer, which is in series with the high voltage winding of the 1st transformer at its high voltage end.
- The rating of the excitation winding is same as that of low voltage winding. 3rd transformer is kept on insulator above the ground at a potential of $2V_2$. output of 3 stage is $3V_2$.
- The rating of the low voltage winding of 230 or 400 V can be used to produce 3.3 kV, 6.6 kV or 11 kV.\

GENERATION OF HIGH AC VOLTAGE

CASCADE TRANSFORMER

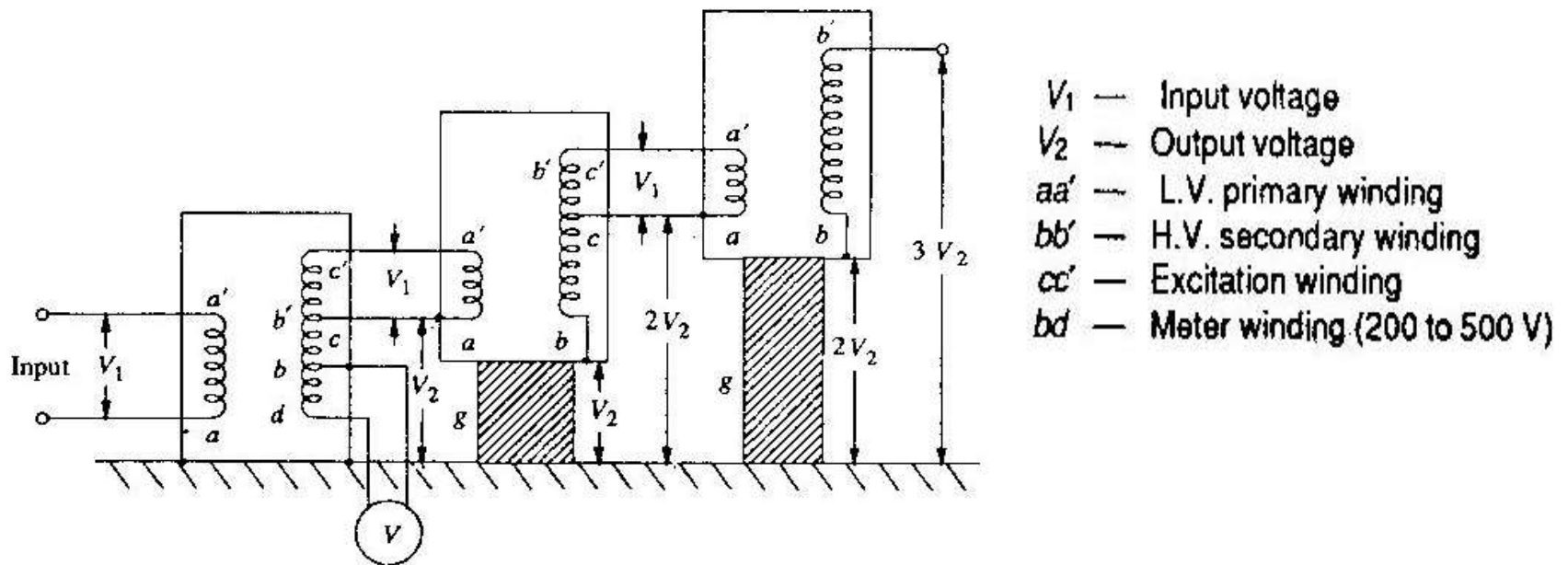

Cascade transformer connection (schematic)

GENERATION OF HIGH AC VOLTAGE

Cascade transformer with isolating transformer for excitation

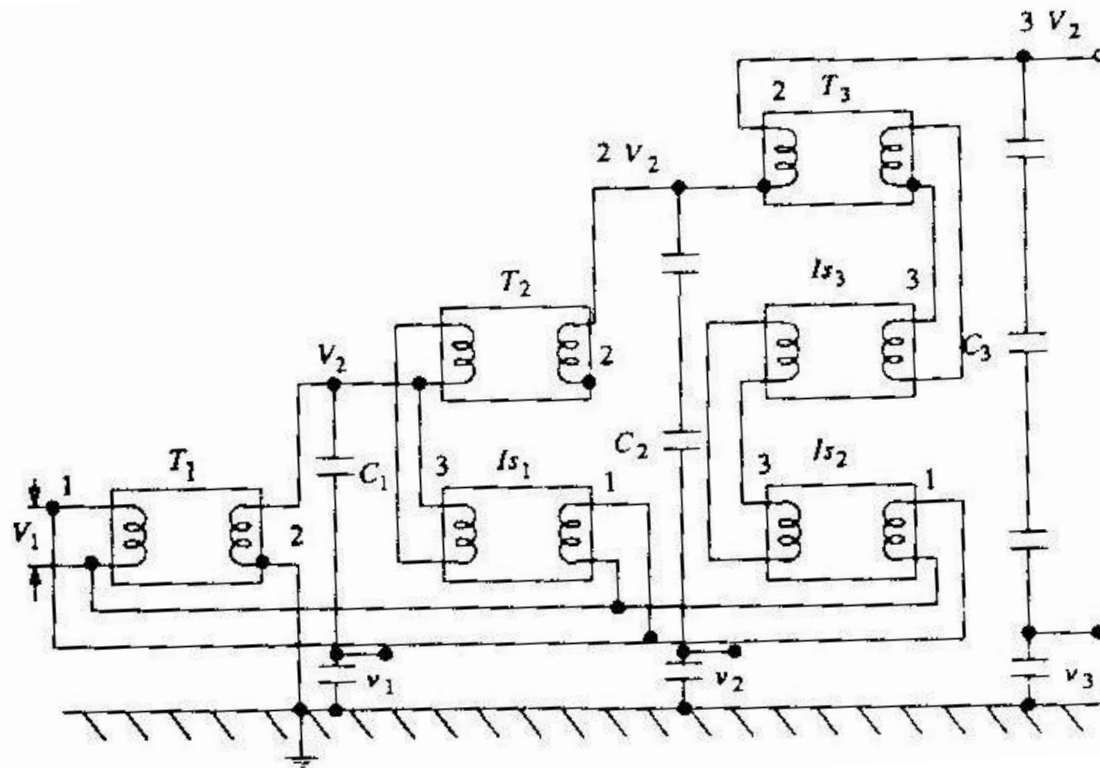



GENERATION OF HIGH FREQUENCY A.C HIGH VOLTAGES

- High frequency high voltage damped oscillations are needed which need high voltage high frequency transformer which is a Tesla coil.
- Tesla coil is a doubly tuned resonant circuit, primary voltage rating is 10 kV and secondary voltage rated from 500 to 1000 kV.
- The primary is fed from DC or AC supply through C1. A spark gap G connected across the primary is triggered at V1 which induces a high self excitation in the secondary. The windings are tuned to a frequency of 10 to 100 kHz.



GENERATION OF IMPULSE VOLTAGES

STANDARD IMPULSE WAVESHAPE

- It is specified by rise or front time, fall or tail time to 50% peak value and peak value.
- 1.2/50 μ s, 1000 kV.



MARX CIRCUIT

- Charging resistance R_s is limiting the charging current from 50 to 100 mA. CRs is about 10s to 1 min.
- The gap spacing G is greater than the charging voltage V . All the capacitance s are charged to the voltage V in 1 min.
- The spark gap G is made spark over, then all the capacitor C get connected in series and discharge into the load load
- In modified Marx circuit, R_1 is divided into n parts equal to R_1/n and put in series with the gap G , R_2 is divided into n parts equal to R_2/n and connected across each capacitor unit after the gap G .
- The nominal output is the number of stages multiplied by the charging voltage.

MULTISTAGE IMPULSE GENERATOR MARX CIRCUIT

- A single capacitor C1 is to be charged first and then discharged into wave shaping circuits and it is limited to 200 kV
- For producing very high voltages a bank of capacitors are charged in parallel and then discharged in series.

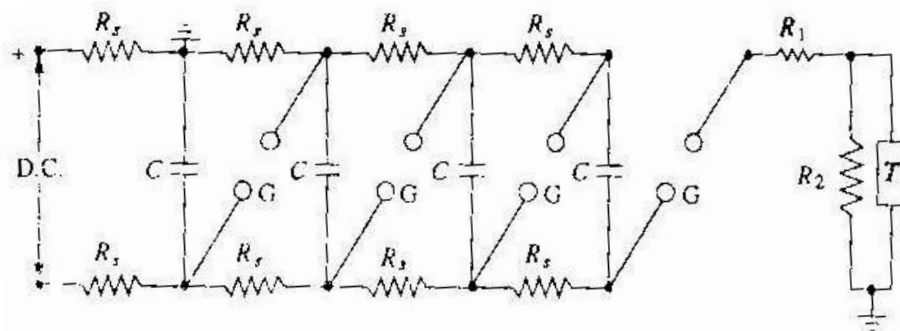

- C — Capacitance of the generator
- R_s — Charging resistors
- G — Spark gap
- R_1, R_2 — Wave shaping resistors
- T — Test object

MULTI STAGE IMPULSE GENERATORS

Modified Marx Circuit

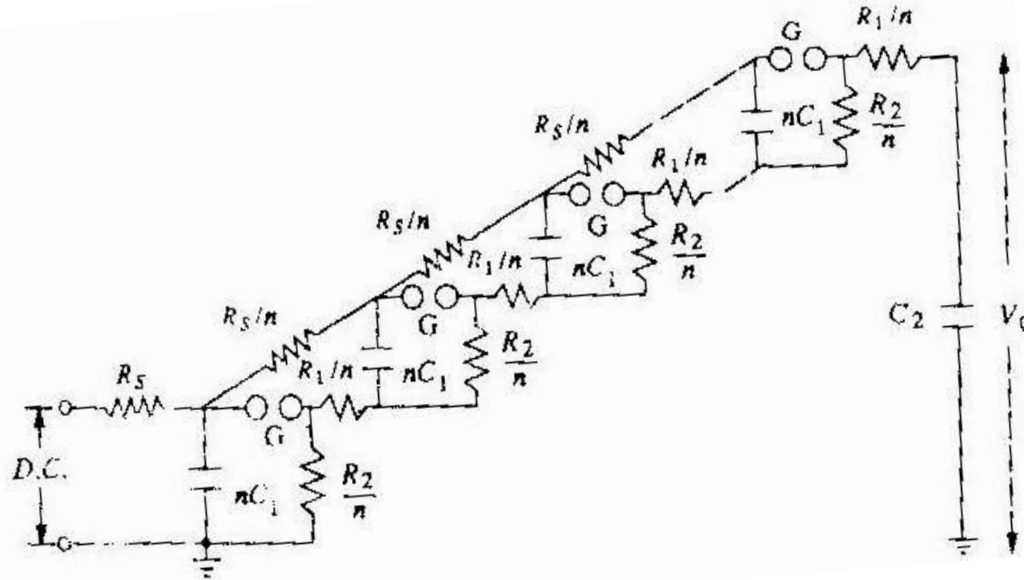



COMPONENTS OF A MULTISTAGE IMPULSE GENERATOR

- DC Charging set
- Charging resistors
- Generator capacitors and spark gaps
- Wave shaping resistors and capacitors
- Triggering system
- Voltage dividers



GENERATION OF SWITCHING SURGES

- A switching surge is a short duration transient voltage produced in the system due to a sudden opening or closing of a switch or c.b or due to an arcing at a fault in the system.
- Impulse generator circuit is modified to give longer duration wave shape, $100/1000 \mu\text{s}$, R_1 is increased to very high value and it is parallel to R_2 in the discharge circuit.
- Power transformer excited by DC voltages giving oscillatory waves which produces unidirectional damped oscillations. Frequency of 1 to 10 kHz
- Switching surges of very high peaks and long duration can be obtained by one circuit, In this circuit C_1 charged to a low voltage d.c (20 to 25 kV) is discharged into the low voltage winding of a power transformer. The high voltage winding is connected in parallel to a load capacitance C_2 , potential divider R_2 , gap S and test object.



GENERATION OF IMPULSE CURRENTS

- For producing impulse currents of large value, a bank of capacitors connected in parallel are charged to a specified value and are discharged through a series R-L circuit.
- $I_m = V(\exp(-\alpha t))\sin(\omega t)/\omega L$



GENERATION OF HIGH IMPULSE CURRENTS

- For producing large values of impulse, a no. of capacitors are charged in parallel and discharged in parallel into the circuit.
- The essential parts of an impulse current generator are:
 - (i) a.d.c. charging unit
 - (ii) capacitors of high value (0.5 to 5 μF)
 - (iii) an additional air cored inductor
 - (iv) proper shunts and oscillograph for measurement purposes, and
 - (v) a triggering unit and spark gap for the initiation of the current generator.



TRIPPING AND CONTROL OF IMPULSE GENERATORS

- In large impulse generators, the spark gaps are generally sphere gaps or gaps formed by hemispherical electrodes.
- The gaps are arranged such that sparking of one gap results in automatic sparking of other gaps as overvoltage is impressed on the other.
- A simple method of controlled tripping consists of making the first gap a three electrode gap and firing it from a controlled source.



TRIPPING AND CONTROL OF IMPULSE GENERATORS

- The first stage of the impulse generator is fitted with a three electrode gap, and the central electrode is maintained at a potential in between that of the top and the bottom electrodes with the resistors $R1$ and RL .
- The tripping is initiated by applying a pulse to the thyration G by closing the switch S.
- C produces an exponentially decaying pulse of positive polarity.
- The Thyatron conducts on receiving the pulse from the switch S and produces a negative pulse through the capacitance C1 at central electrode.
- Voltage between central electrode and the top electrode those above sparking potential and gap contacts.



TRIPPING CIRCUIT USING A TRIGATRON

- This requires much smaller voltage for operation compared to the three electrode gap.
- A trigatron gap consists of a high voltage spherical electrode, an earthed main electrode of spherical shape, and a trigger electrode through the main electrode.
- Tripping of the impulse generator is effected by a trip pulse which produces a spark between the trigger electrode and the earthed sphere.
- Due to space charge effects and distortion of the field in the main gap, spark over of the main gap occurs and it is polarity sensitive.



UNIT IV

MEASUREMENT OF HIGH VOLTAGES AND CURRENTS

MEASUREMENT OF HIGH DC VOLTAGE



- Series resistance micrometer
- Resistance potential divider
- Generating voltmeter
- Sphere and other sphere gaps

SERIES RESISTANCE MICROMETER

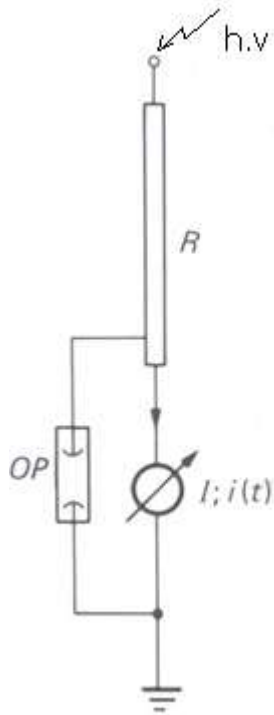

- A very high resistance in series with a micrometer.
- $V = IR$
- The resistance is constructed from a large no. of wire wound resistors in series.

RESISTANCE POTENTIAL DIVIDER

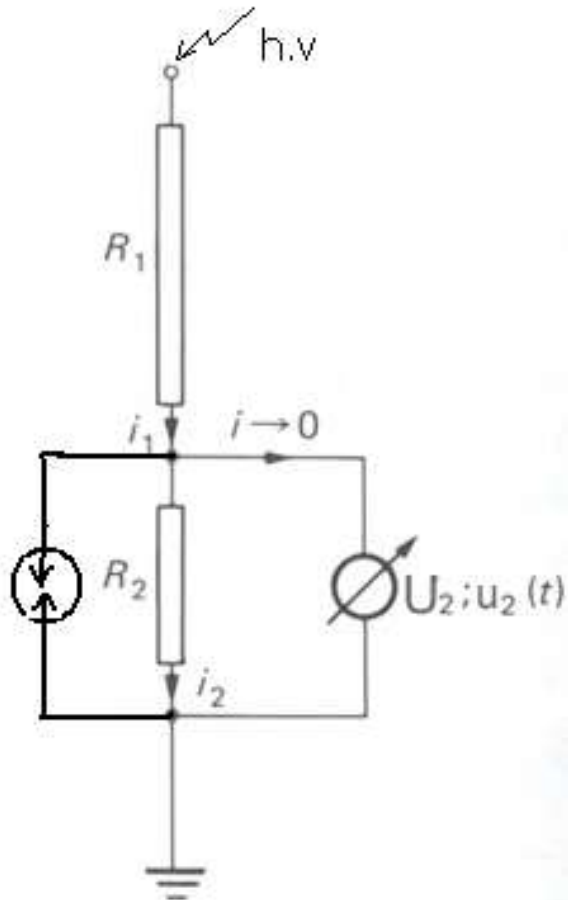

MEASUREMENT OF HIGH AC VOLTAGE



- Series impedance voltmeter
- Potential dividers
(resistance or capacitance type)
- Potential transformers
(Electromagnetic or CVT)
- Electrostatic voltmeter
- Sphere gaps

SERIES IMPEDANCE VOLTMETER

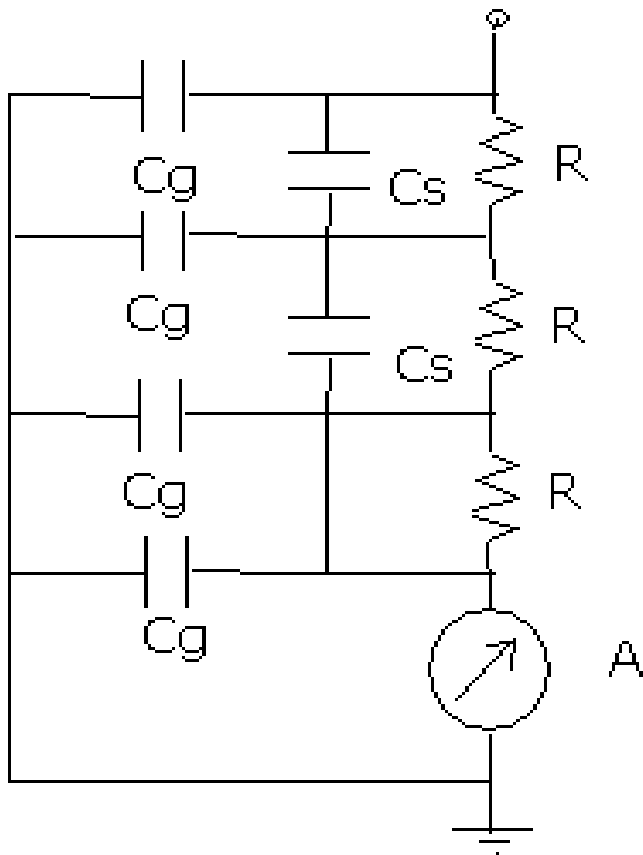

Extended
series
impedance
with
inductance
neglected

ELECTROSTATIC VOLTMETER

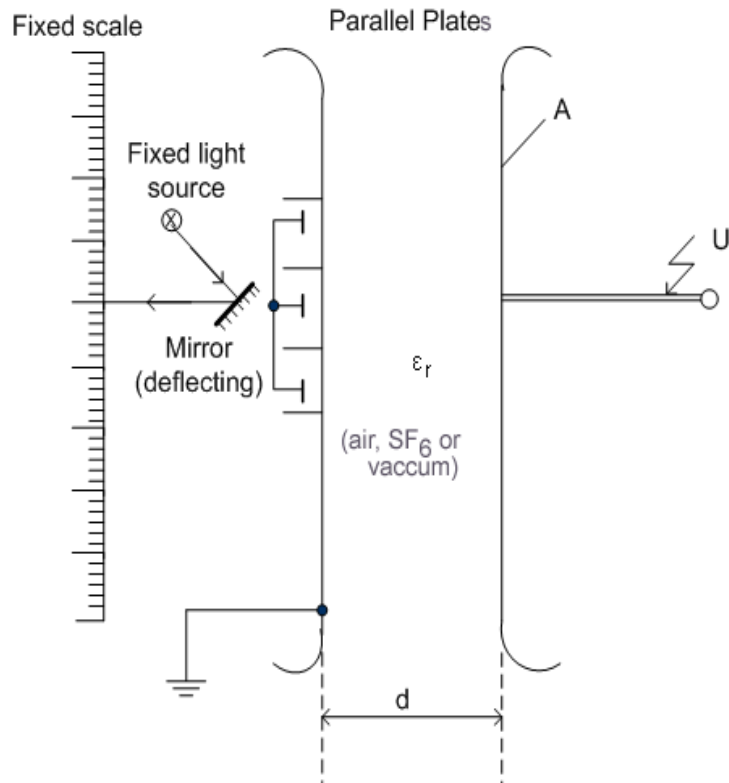

$$F = -\frac{\partial W_{el}}{\partial d}$$

$$|F| = \frac{dW_{el}}{dd} = \frac{d}{dd} \left(\frac{1}{2} CU^2 \right)$$

$$= \frac{1}{2} U^2 \frac{dC}{dd} = \frac{1}{2} U^2 \epsilon_0 \frac{d}{dd} \left(\frac{A}{d} \right) \quad (\text{since } \epsilon_r = 1)$$

$$= \frac{1}{2} \epsilon_0 U^2 \cdot \frac{A}{d^2}$$

$$|F| = \frac{1}{2} \epsilon_0 A E^2$$

$$\frac{1}{T_0} \int F(t) dt = \frac{\epsilon_0 A}{2d^2} \cdot \frac{1}{T_0} \int u^2(t) dt = \frac{\epsilon_0 A}{2d^2} (U_{rms})^2$$

SERIES CAPACITOR PEAK VOLTMETER

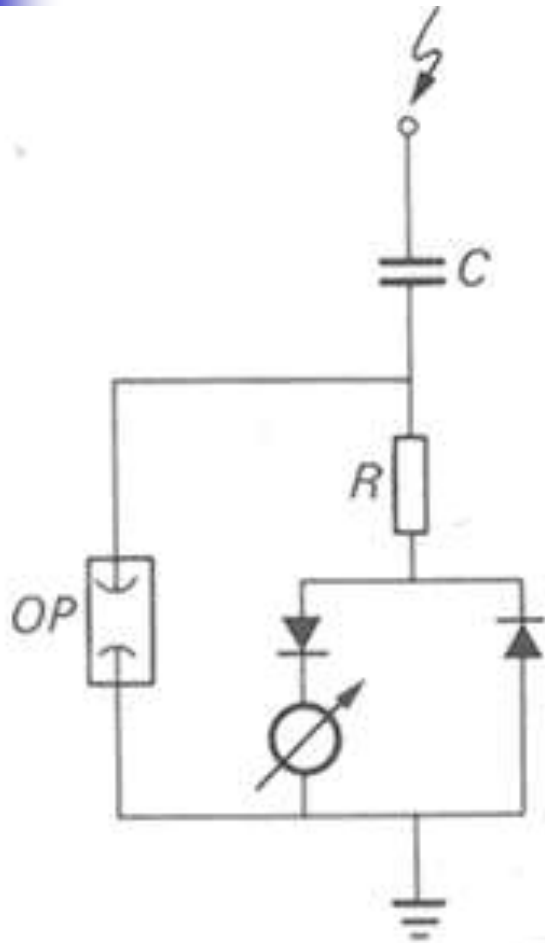

C – capacitor

D_1, D_2 – Diodes

OP – Protective devices

I – indicating meter

$V(t)$ – voltage waveform

$I_c(t)$ – capacitor current
waveform

T – period

PEAK READING AC VOLTMETER

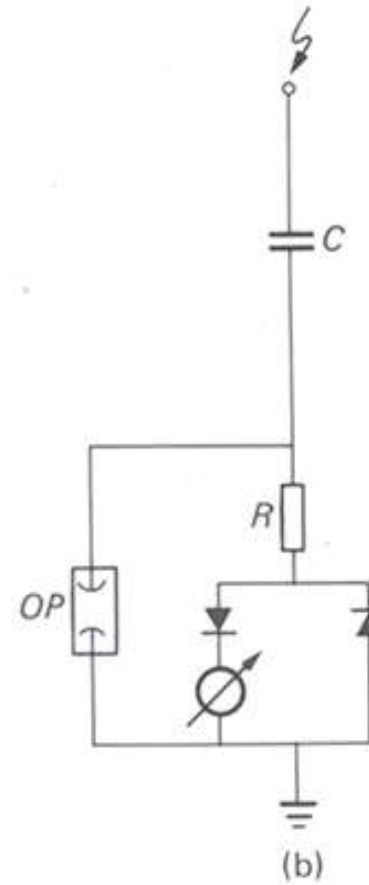
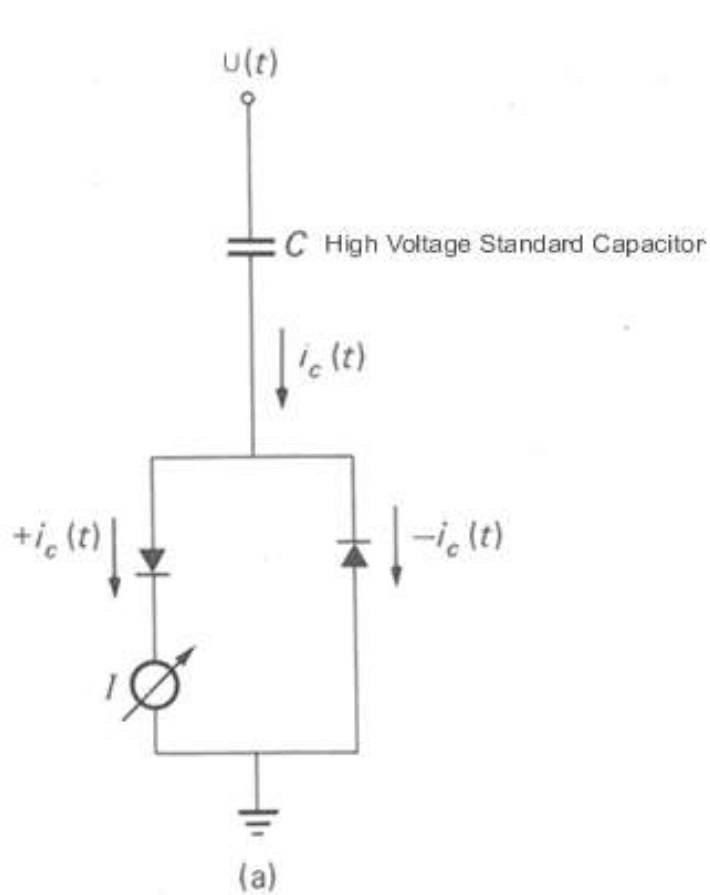

PEAK READING AC VOLTMETER

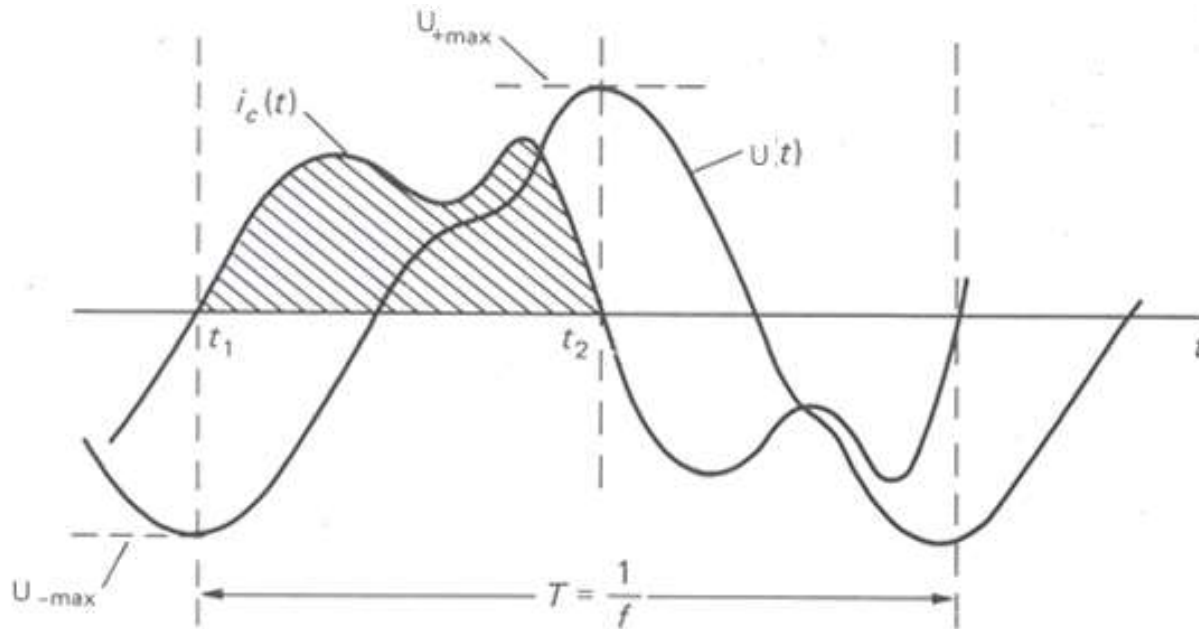

SPHERE GAPS MEASUREMENT

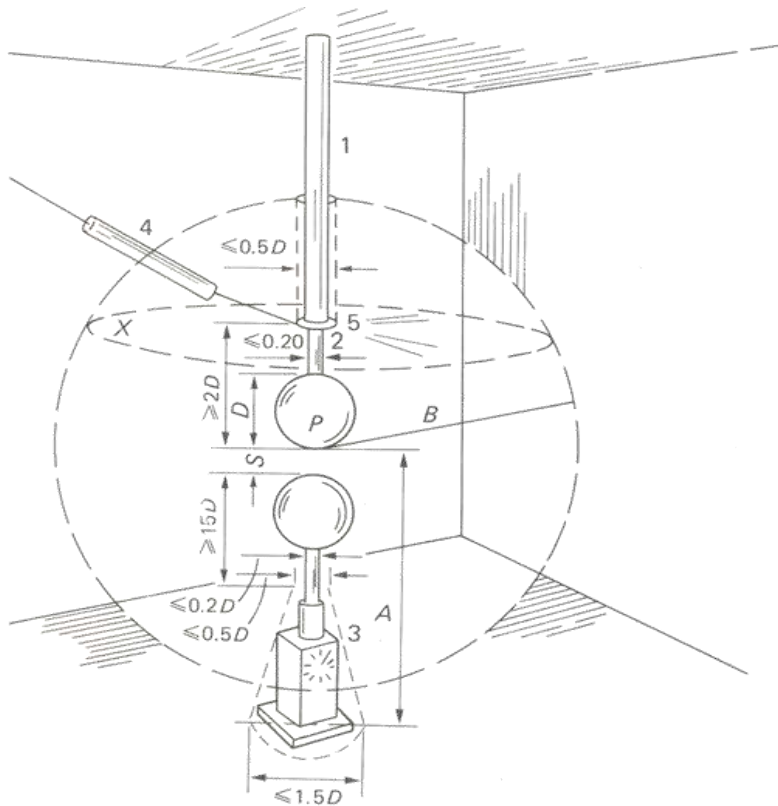

$$U_b = k_d U_{b0}$$

$$\delta = \frac{p}{p_0} \frac{273 + t_0}{273 + t} = \frac{p}{p_0} \cdot \frac{T_0}{T}$$

SPHERE GAPS



Potential divider for impulse voltage measurement

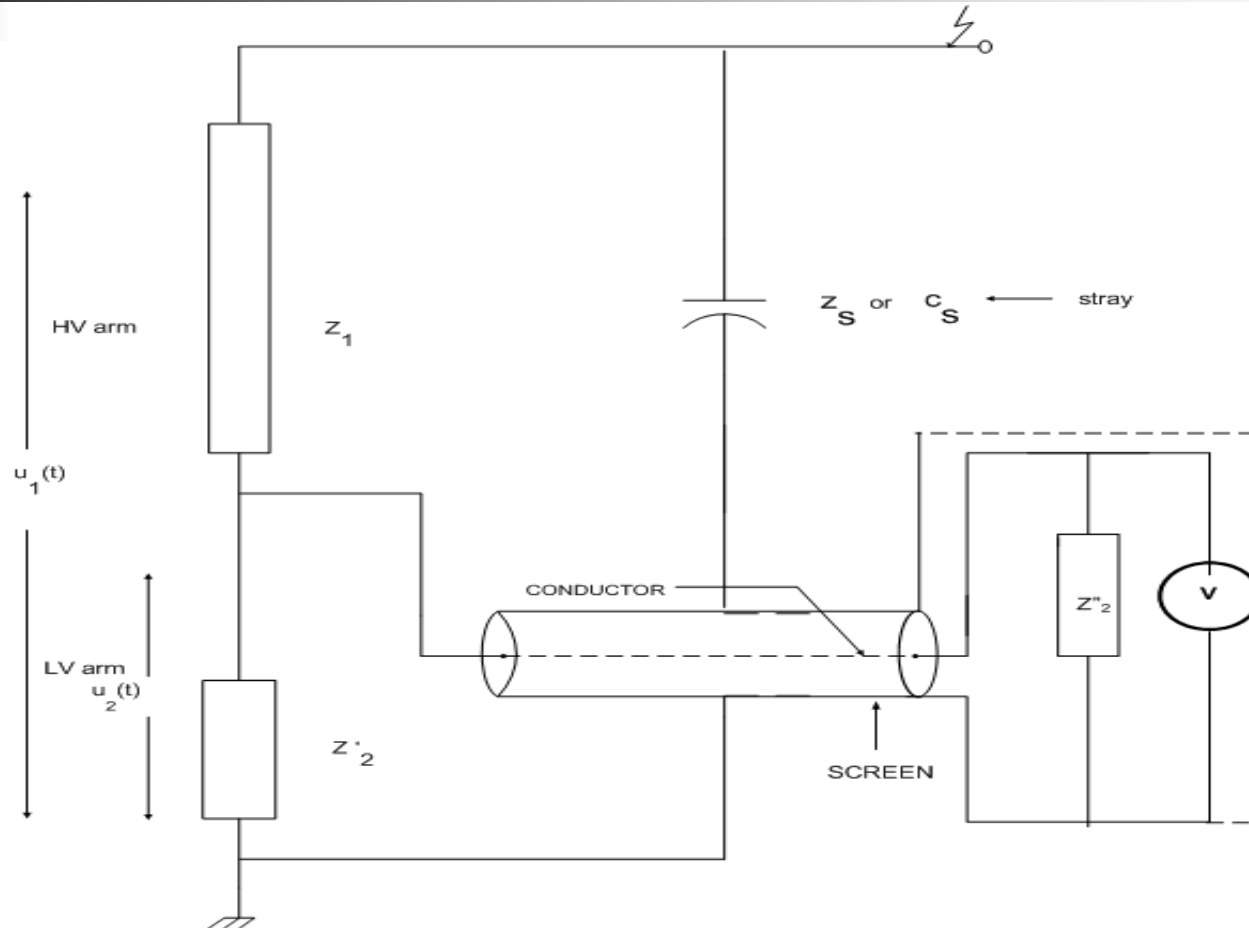



MEASUREMENT OF HIGH DIRECT CURRENTS

HALL GENERATORS FOR D.C CURRENT MEASUREMENTS

- Hall effect principle is used. If an electric current flows through a metal plate located in a magnetic field perpendicular to it, Lorentz forces will deflect the electrons in the metal structure in a direction normal to the direction of both the current and magnetic field.
- The charge displacement generates an emf in the normal direction (Hall voltage).
- $V_H = RB_i/d$
- $H = I/\delta$



MEASUREMENT OF HIGH POWER FREQUENCY ALTERNATING CURRENTS

- Current transformer is used.it uses electro optical technique.
- A voltage signal proportional to the measuring current is generated and it is transmitted to the ground side through electro optical device.
- Light pulses proportional to the voltage signal are transmitted by a glass optical fibre bundle to a photo detector and converted back into an analog voltage signal.



UNIT V

HIGH VOLTAGE TESTING OF ELECTRICAL APPARATUS



TESTS OF INSULATORS

- type test to check the design features
- routine test to check the quality of the individual test piece.
- High voltage tests include
 - (i) Power frequency tests
 - (ii) impulse tests



TESTS OF INSULATORS

POWER FREQUENCY TESTS

- (a) Dry and wet flashover tests:
- a.c voltage of power frequency is applied across the insulator and increased at a uniform rate of 2% per second of 75% of their estimated test voltage.
 - If the test is conducted under normal conditions without any rain –dry flashover test.
 - If the test is conducted under normal conditions of rain –wet flashover test

(b) Dry and wet withstand tests(one minute)

The test piece should withstand the specified voltage which is applied under dry or wet conditions.



IMPULSE TESTS ON INSULATORS

- Impulse withstand voltage test

If the test object has withstood the subsequent applications of standard impulse voltage then it is passed the test

- Impulse flashover test

The average value between 40% and 60% failure is taken, then the insulator surface should not be damaged.

- Pollution Testing

Pollution causes corrosion, deterioration of the material, partial discharges and radio interference. Salt fog test is done.



TESTING OF BUSHINGS

Power frequency tests

(a) Power Factor-Voltage Test

Voltage is applied up to the line value in increasing steps and then reduced. The capacitance and power factor are recorded in each step.

(b) Internal or Partial discharge Test

This is done by using internal or partial discharge arrangement.

(c) Momentary Withstand Test at Power frequency

The bushing has to withstand the applied test voltage without flashover or puncture for 30 sec.

(d) One Minute withstand Test at Power Frequency

The bushing has to withstand the applied test voltage without flashover or puncture for 1 min.

(d) Visible Discharge Test at Power Frequency

No discharge should be visible when standard voltage is applied.



IMPULSE VOLTAGE TESTS ON BUSHING

- Full wave Withstand Test

The bushing is tested for either polarity voltages, 5 consecutive full wave is applied, If the test object has withstood the subsequent applications of standard impulse voltage then it is passed the test.

- Chopped Wave Withstand and Switching Surge Tests

It is same as full wave withstand test but it is done for high voltage bushings(220 kV and 400 kV)



IMPULSE VOLTAGE TESTS ON BUSHING

THERMAL TESTS ON BUSHING

Temperature Rise and Thermal Stability Tests

- Temperature rise test is done at temperature below 40°C at a rated power frequency. The steady temperature rise should not exceed 45°C .
- Thermal stability test is done for bushing rated for 132 kV above.



TESTING OF ISOLATORS AND CIRCUIT BREAKERS

Dielectric tests

Overvoltage withstand test of power frequency, lightning and switching impulse voltages.

The impulse test

impulse test and switching surge tests with switching over voltage are done.

Temperature and mechanical tests

tube tests are done.



TESTING OF ISOLATORS AND CIRCUIT BREAKERS

Short circuit tests

- (a) Direct tests
- (b) using a short circuit generator as the source
- (c) using the power utility system as the source.



SYNTHETIC TESTS ON CIRCUIT BREAKER AND ISOLATOR

(a) Direct testing in the Networks or in the Fields

This is done during period of limited energy consumption or when the electrical energy is diverted to other sections of the network which are not connected to the circuit under the test.

(b) Direct Testing in short Circuit Test Laboratories

A make switch initiates the short circuit and the master c.b isolates the test device from the source at the end of predetermine time setnon a test controller.



SYNTHETIC TESTS ON CIRCUIT BREAKER AND ISOLATOR

(c) Synthetic Testing of Circuit Breakers

In the initial period of the short circuit test, a.c current source supplies the heavy current at a low voltage, and recovery voltage is simulated by a source of high voltage of small current capacity.

(d) Composite Testing

The C.B is tested first for its rated breaking capacity at a reduced voltage and afterwards for rated voltage at a low current.

(e) Unit Testing

When large C.B of very high voltage rating (220 kV and above) are to be tested and where more than one break is provided per pole, the breaker is tested for one break at its rated current and the estimated voltage.



SYNTHETIC TESTS ON CIRCUIT BREAKER AND ISOLATOR

(f) Testing Procedure

The C.B are tested for their breaking capacity B and making capacity Mand it is tested for following duty cycle

- (1) B-3-B-3-B at 10% of the rated symmetrical breaking capacity
- (2) B-3-B-3-B at 30% of the rated symmetrical breaking capacity
- (3) B-3-B-3-B at 60% of the rated symmetrical breaking capacity
- (4) B-3-MB-3MB-MB0 at 10% of breaking capacity with the recovery voltage not less 95% of the rated service voltage

(g) Asymmetrical Tests

One test cycle is repeated for the asymmetrical breaking capacity in which the d.c component at the instant of contact separation is not less than 50% of the a.c component



TESTING OF CABLES

Different tests on cables are

- (i) mechanical tests like bending test, dripping and drainage test, and fire resistance and corrosion tests
- (ii) Thermal duty tests
- (iii) Dielectric power factor tests
- (iv) Power frequency withstand voltage tests
- (v) impulse withstand voltage tests
- (vi) Partial discharge test
- (vii) Life expectancy tests



TETSING OF TRANSFORMERS

(a) Induced Over voltage Test

It is tested for overvoltages by exciting the secondary from a high frequency a.c source(100 to 400 Hz) to about twice the rated voltage.

(b) Partial Discharge Tests

It is done to assess the discharge magnitudes and radio interference levels.



TETSING OF TRANSFORMERS

IMPULSE TESTING OF TRANSFORMERS

(a) Procedure for Impulse Testing

- (i) applying impulse voltage of magnitude 75% of the BIL
- (ii) one full wave voltage of 100% BIL
- (iii) two chopped waves of 100% BIL
- (iv) one full wave voltage of 100% BIL
- (v) one full wave of 75% BIL



TETSING OF TRANSFORMERS

(b) Detection and Location of fault during impulse testing

The fault in a transformer insulation is located in impulse tests by any one of the following methods.

- (i) General observations
- (ii) Voltage oscillogram method
- (iii) Neutral current method
- (iv) Transferred surge current method



TESTING OF SURGE DIVERTERS

(i) Power frequency spark over test

It is a routine test. The test is conducted using a series resistance to limit the current in case a spark over occurs. It has to withstand 1.5 times the rated value of the voltage for 5 successive applications.

(ii) 100% standard impulse spark over test

This test is conducted to ensure that the diverter operates positively when over voltage of impulse nature occur. The test is done with both positive and negative polarity waveforms. The magnitude of the voltage at which 100% flashover occurs is the required spark over voltage.



TESTING OF SURGE DIVERTERS

(iii) Residual voltage test

This test is conducted on pro rated diverters of ratings in the range 3 to 12 kV only. standard impulse currents of the rated magnitudes are applied, voltage across it is recorded.

V_1 = rating of the complete unit

V_2 = rating of the prorated unit tested

V_{R1} = residual voltage of the complete unit

V_{R2} = residual voltage of the complete unit

$$V_1/V_2 = V_{R1}/V_{R2}$$



HIGH CURRENT IMPULSE TEST ON SURGE DIVERTERS

The unit is said to pass the test if

- (i) the power frequency sparkover voltage before and after the test does not differ by more than 10%
- (ii) The voltage and current waveforms of the diverter do not differ in the 2 applications
- (iii) the non linear resistance elements do not show any puncture or flashover



HIGH CURRENT IMPULSE TEST ON SURGE DIVERTERS

- (a) Long Duration Impulse Current Test
- (b) Operating Duty Cycle Test
- (c) Other tests are
 - (1) mechanical tests like porosity test, temperature cycle tests
 - (2) pressure relief test
 - (3) the voltage withstand test on the insulator housing of the insulator
 - (4) the switching surge flashover test
 - (5) the pollution test



INSULATION CO-ORDINATION

- A gradation of system insulation and protective device operation is to be followed.
- Substations contain transformers and switchgear with non-self restoring insulation should be protected against flashover
- For other apparatus which contain self restoring insulation may be allowed to flashover.
- Lightning impulse withstand level known as Basic Insulation Level(BIL). Various equipment and their component parts should have their BIL above the system protective level by a margin which is determined with respect to air insulation.



INSULATION CO-ORDINATION

- For higher system voltages, switching surges are of higher magnitude compared to the lightning over voltages.
- The flashover voltage of a protective device is chosen such that it will not operate for switching overvoltage and other power frequency and its harmonic overvoltages. BIL has to be higher.
- For EHV systems, Switching Impulse Level (SIL) should be assigned to each protective device.



**Gokaraju Rangaraju Institute of Engineering & Technology
(Autonomous)**

Summation of Teacher Appraisal by Student
Academic Year 2018-19

| | |
|--|-------------|
| Name of the Instructor | V Usha Rani |
| Faculty ID | 1045 |
| Branch | EEE |
| Class and Semester/Section | IV / I / B |
| Academic Year | 2018-19 |
| Subject Title | HVE |
| Total No. of Responses/class strength | 28/71 |

Average rating on a scale of 4 for the responses considered:

| S. No | Questions of Feedback | Average |
|--------------|--|--------------------|
| 1 | How do the teacher explain the subject? | 3.1944444444444446 |
| 2 | The teacher pays attention to | 3.1111111111111112 |
| 3 | The Language and communication skills of the teacher is | 3.1666666666666665 |
| 4 | Is the session Interactive? | 3.1388888888888888 |
| 5 | Rate your teacher's explanation in clearing the doubts | 3.1944444444444446 |
| 6 | Rate your teachers commitment in completing the syllabus | 3.0277777777777777 |
| 7 | Rate your teachers punctuality | 3.0833333333333335 |
| 8 | Rate your teachers use of teaching aids | 3.1944444444444446 |
| 9 | Rate your teacher's guidance in other activities like NPTEL, Moodle, Swayam, Projects. | 3.0833333333333335 |
| 10 | What is your overall opinion about the teacher? | 3.1944444444444446 |

Net Feedback on a scale of 1 to 4: 3.1388888888888884

Remarks by HOD:

Remarks by Principal:

Remarks by Director:
